

# COMPANY PROFILE

## 公司概况



宁波九龙电讯电机有限公司，成立于1990年，是从事全系列的交流轴流风机，直流风机，冷却风机，横流风扇，涡流风机，离心风机及风机配件研制生产的现代化专业制造企业，积累了丰富的生产经验。

在2004年，创建了宁波龙泰电讯电机有限公司，公司占地面积25000平方米，拥有生产，研发及办公大楼等建筑面积20000平方米。它位于风景优美的海滨城市象山，属于宁波市，靠近上海市，具有非常便利的海陆交通。

我们的产品广泛应用于：IT领域，运动器材，通风设备，焊接设备，电源系统，医疗电子仪器，机械设备等行业。公司通过并一直按照ISO9001-2000国际质量管理体系操作，现在已导入环境管理体系。产品已通过多个国家和地区的安全认证，如：UL，CUL，TUV，CE，CCC等。

强大的技术力量和完善的检测设备，使我们有能力提供一流的品质和专业的技术支持。我们公司始终以“质量求生存，价格求生产，产品求发展，管理出效益”的理念为宗旨，这使我们赢得了良好的声誉和知名度。经过了21年的努力，现今“九龙”品牌产品已畅销国内众多知名企业及各大风机市场，并出口到欧洲，美洲，大洋州，东南亚以及中东等各大市场。

我们致力于提供最佳散热方案，热烈欢迎海内外各界人士莅临本公司洽谈电机研制，生产，合作等各项业务。

Established in 1990, Ningbo Jiulong Telecommunication and Electrical Machinery Co.,Ltd is a modern manufacturer specialized in all kinds of AC axial fans, DC fans, cooling fans, cross flow fans, centrifugal fans and fan accessories with profuse of experience.

In year 2004, it founded Ningbo Longtai Electric Manufacture Co.,Ltd. The company occupied 25,000 square meters of land area, which is located on beautiful seaside country Xiangshan, belongs to Ningbo city, near Shanghai, and it has very convenient traffic both by sea and land.

Our products are widely used in IT areas, sports equipments, ventilation systems, welding machines, power supplies, medical and electrical instruments, machinery equipments and so on. Our company has been operating according to the ISO9001-2000 International Quality Control System, and having ducted into the environmental protection system now. The products have passed safety certification in various countries and regions such as UL, CUL, TUV, CE, CCC, etc.

Powerful techno-energy and complete testing equipments make us have the ability to offer top-ranking quality and professional technical support. Our company always insists on the policy----Live by quality, Produce by value, Develop by products, Benefit by management. It makes the company has high reputation and well-known in China. After long time of hard work, products with "JIULONG" brand are sold well in our domestic market and exported to the countries of Europe, America, Oceania, Southeast Asia, and Middle East now. We apply ourselves to supply the best cooling project. Sincerely welcome you to visit our company to negotiate R&D manufacturing and co-operate in business for varieties of blowers. We will provide only the best quality products and services at any time.

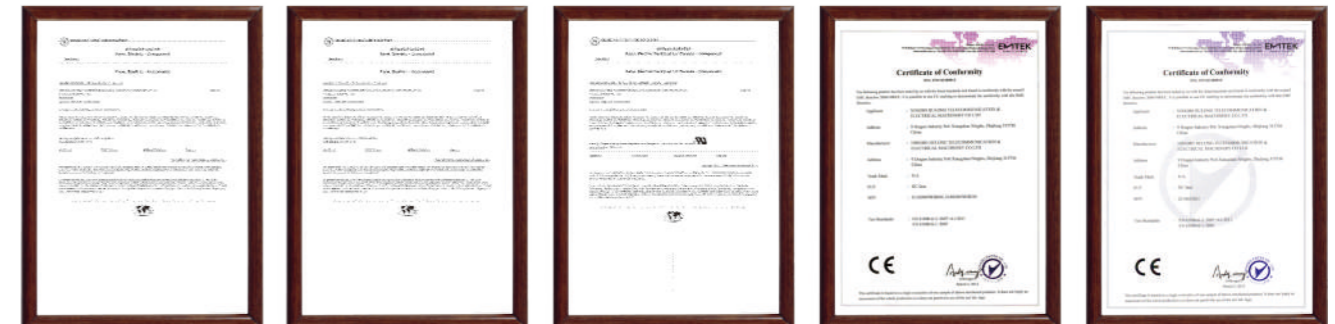

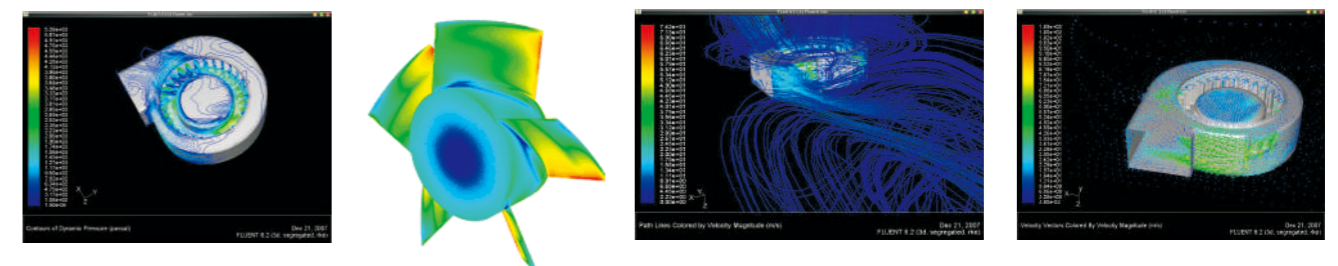
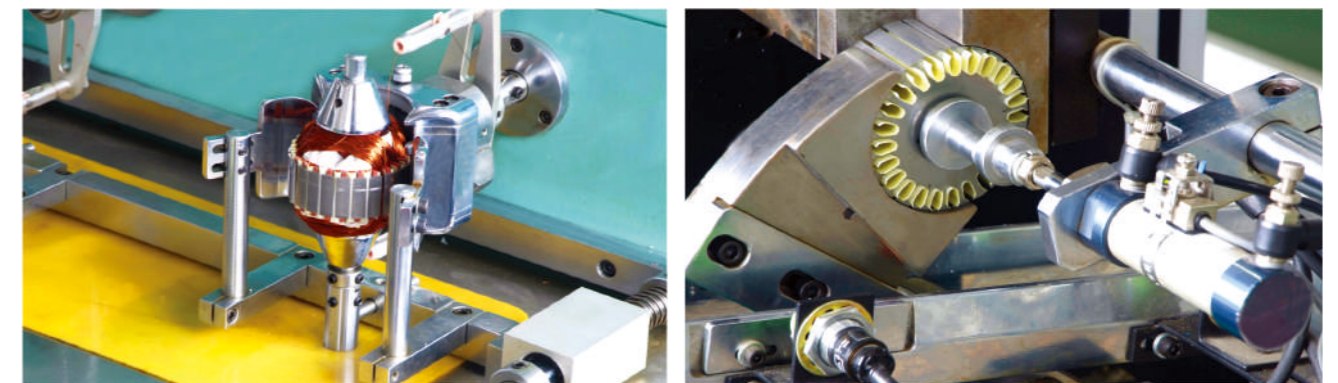

**AC轴流风机**  
AC Axial Fan

1/46



**EC Axial Fan**  
EC 轴流风机

239/248



**AC全金属轴流风扇**  
AC All-Metal Axial Fan

47/98



**EC离心风机**  
EC Centrifugal Fan

249/288



**DC轴流风机**  
DC Axial Fan

99/147



**AC离心风机**  
AC Centrifugal Fan

289/336



**DC离心风机**  
DC Centrifugal Fan

148/238



**风机配件**  
Fan Accessories

337/369

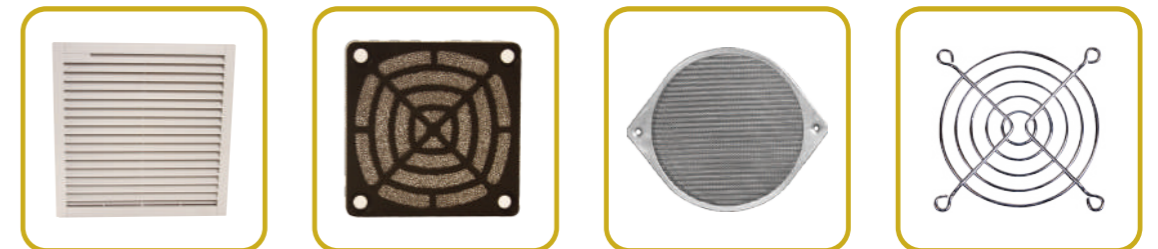

# CONTENTS

## 目录

### 交流轴流风机 AC Axial Fan

1/46



### AC全金属轴流风扇 AC All-Metal Axial Fan

47/98



## MODEL INFORMATION

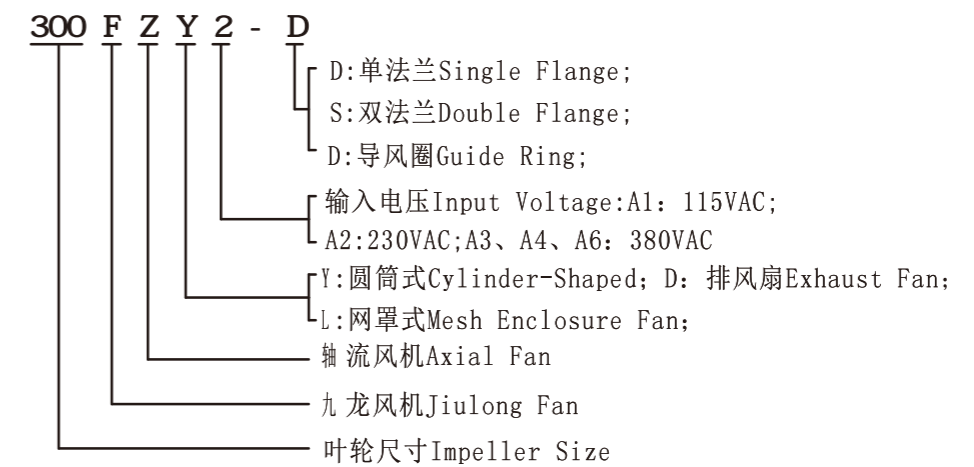
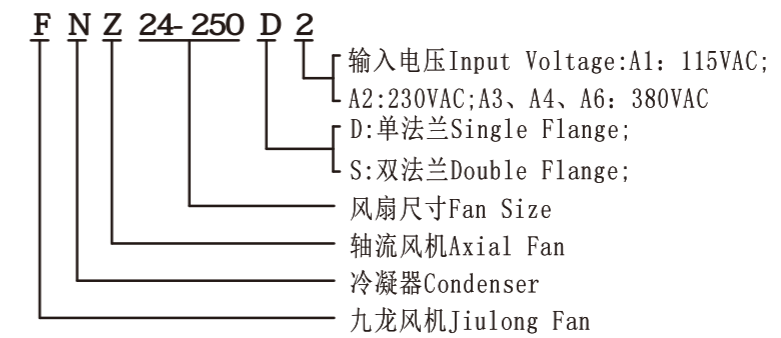
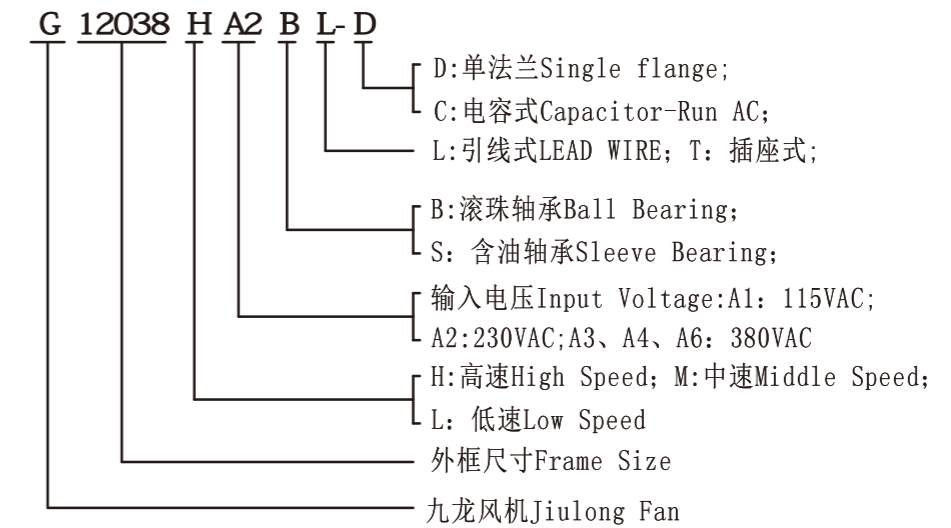

本样册仅做选型参考,具体以规格书为准。  
This sample book is for reference only. Please refer to the specification for details.  
如需特殊电压也可根据洽询提供, 本公司保留技术改动权利。  
Special voltage may be provided if necessary according to the inquiry. Jiulong all technical modification rights reserved.

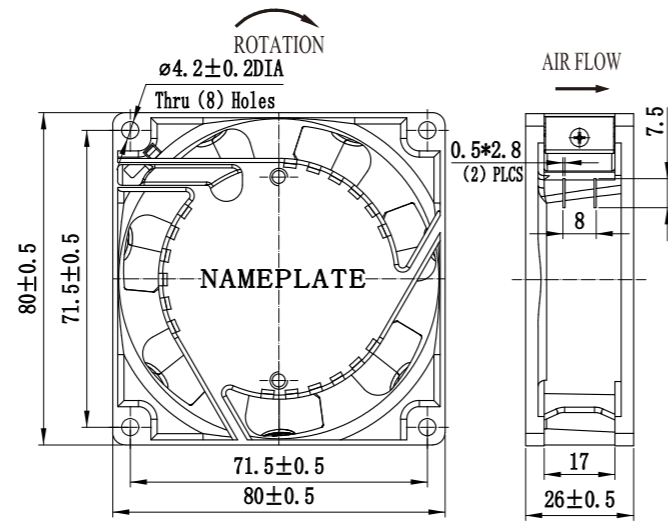

尺寸 Size: 80mm × 80mm × 25mm  
风量 Airflow: 19–23CFM  
重量 Weight: 260g  
噪音 Noise: 23–26dB(A)  
风叶 Impeller Material: PBT UL94–V0 Reinforced Plastic  
外框 Frame: Aluminum Alloy  
端子 Terminals: 0.5mm  
引线 Lead Wire: AWG#22 UL 1569(Optional)  
马达 Motor: Shaded Pole Induction Motor  
温度范围 Operating Temperature: -10°C~+65°C

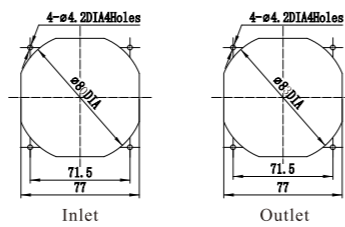

产品型号 Model	轴承型式 Bearing System	电压 Voltage VAC	频率 Freq. Hz	电流 Current A	功率 Power W	转速 Speed RPM	噪音 Noise dB(A)	风量 Air Flow CFM	相数 Phase	电容 Capacitor μF/VAC
G8025HA,S	Sleeve	100/125	50/60	0.15	15/12	2300/2750	26/23	19/23	1	/
G8025HA <sub>2</sub> S		200/240	50/60	0.09	15/12	2300/2750	26/23	19/23	1	/
G8025HA,B	Ball	100/125	50/60	0.15	15/12	2300/2750	26/23	19/23	1	/
G8025HA <sub>2</sub> B		200/240	50/60	0.09	15/12	2300/2750	26/23	19/23	1	/

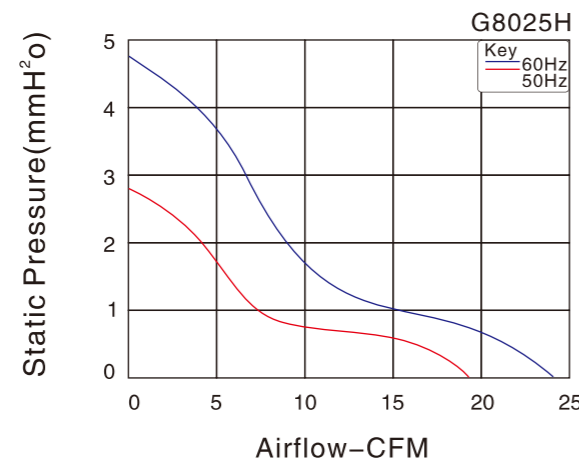

Fan Accessories

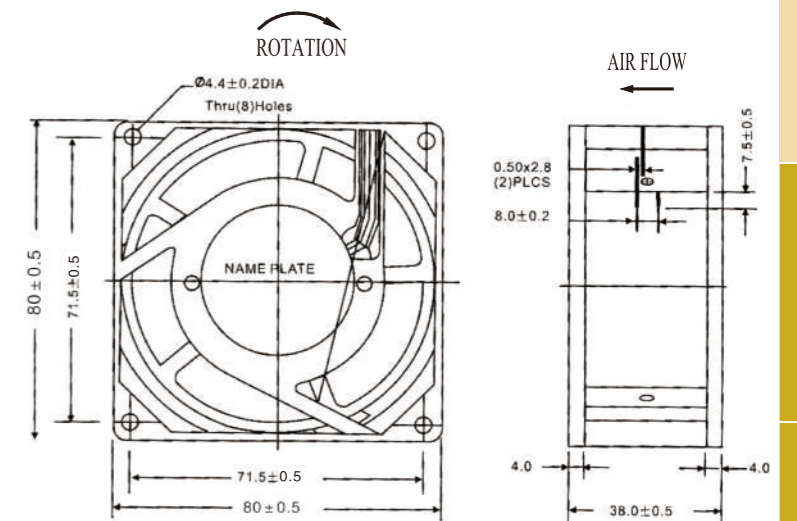
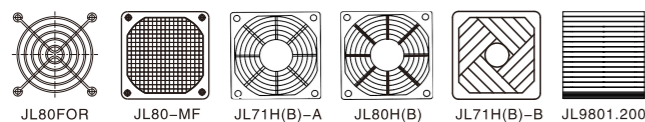

尺寸 Size: 80mm × 80mm × 38mm  
风量 Airflow: 22–28CFM  
重量 Weight: 275g  
噪音 Noise: 26–32dB(A)  
风叶 Impeller Material: PBT UL94–V0 Reinforced Plastic  
外框 Frame: Aluminum Alloy  
端子 Terminals: 0.5mm  
引线 Lead Wire: AWG#22 UL 1569(Optional)  
马达 Motor: Shaded Pole Induction Motor  
温度范围 Operating Temperature: -10°C~+65°C

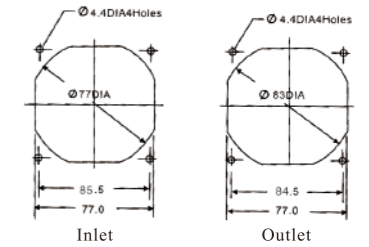

产品型号 Model	轴承型式 Bearing System	电压 Voltage VAC	频率 Freq. Hz	电流 Current A	功率 Power W	转速 Speed RPM	噪音 Noise dB(A)	风量 Air Flow CFM	相数 Phase	电容 Capacitor μF/VAC
G8038HA,S	Sleeve	100/125	50/60	0.2	9.5/7	2550/3100	28/32	23/28	1	/
G8038HA <sub>2</sub> S		200/240	50/60	0.06/0.05	9.5/7	2550/3100	28/32	23/28	1	/
G8038HA,B	Ball	100/125	50/60	0.2	9.5/7	2550/3100	28/32	23/28	1	/
G8038HA <sub>2</sub> B		200/240	50/60	0.06/0.05	9.5/7	2550/3100	28/32	23/28	1	/
G8038MA,S	Sleeve	100/125	50/60	0.13	9/7	2300/2700	26/30	22/26	1	/
G8038MA <sub>2</sub> S		200/240	50/60	0.065	7/6	2300/2700	26/30	22/26	1	/
G8038MA,B	Ball	100/125	50/60	0.13	9/7	2300/2700	26/30	22/26	1	/
G8038MA <sub>2</sub> B		200/240	50/60	0.065	7/6	2300/2700	26/30	22/26	1	/

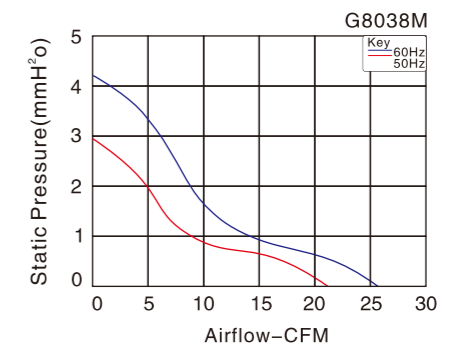
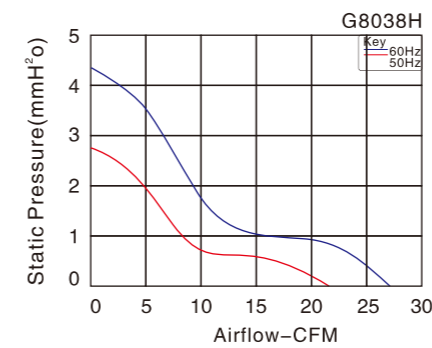

Fan Accessories

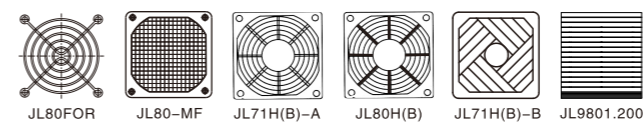

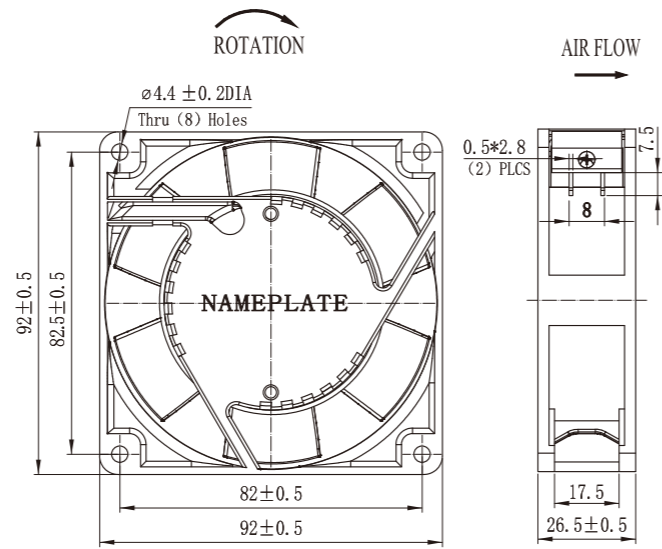

尺寸 Size: 92mm × 92mm × 25mm  
风量 Airflow: 23–37CFM  
重量 Weight: 268g  
噪音 Noise: 23–40dB(A)  
风叶 Impeller Material: PBT UL94–V0 Reinforced Plastic  
外框 Frame: Aluminum Alloy  
端子 Terminals: 0.5mm  
引线 Lead Wire: AWG#22 UL 1569(Optional)  
马达 Motor: Shaded Pole Induction Motor  
温度范围 Operating Temperature: -10°C~+65°C

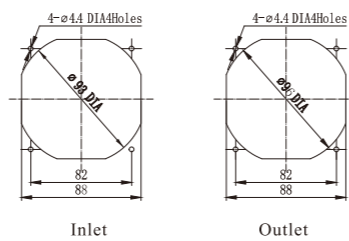

产品型号 Model	轴承型式 Bearing System	电压 Voltage VAC	频率 Freq. Hz	电流 Current A	功率 Power W	转速 Speed RPM	噪音 Noise dB(A)	风量 Air Flow CFM	相数 Phase	电容 Capacitor μF/VAC
G9225HA,S	Sleeve	100/125	50/60	0.2/0.16	16/13	2350/2800	34/40	30/37	1	—
G9225HA <sub>2</sub> S		200/240	50/60	0.1/0.08	16/13	2350/2800	34/40	30/37	1	—
G9225HA,B	Ball	100/125	50/60	0.2/0.16	13/11	2350/2800	34/40	30/37	1	—
G9225HA <sub>2</sub> B		200/240	50/60	0.1/0.08	13/11	2350/2800	34/40	30/37	1	—
G9225MA,B	Sleeve	100/125	50/60	0.14	7/6	1800/2300	23/30	23/30	1	—
G9225MA <sub>2</sub> B		200/240	50/60	0.07	7/6	1800/2300	23/30	23/30	1	—
G9225MA,B	Ball	100/125	50/60	0.14	7/6	1800/2300	23/30	23/30	1	—
G9225MA <sub>2</sub> B		200/240	50/60	0.07	7/6	1800/2300	23/30	23/30	1	—

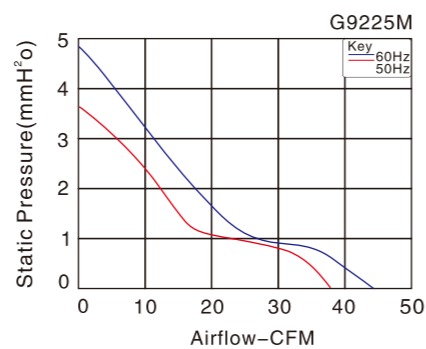
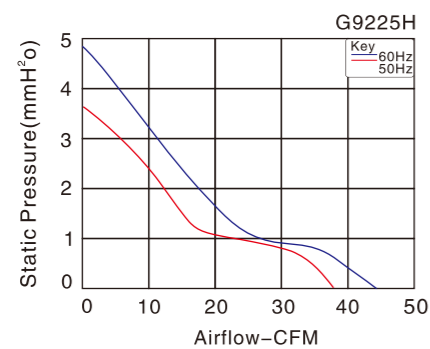

Fan Accessories

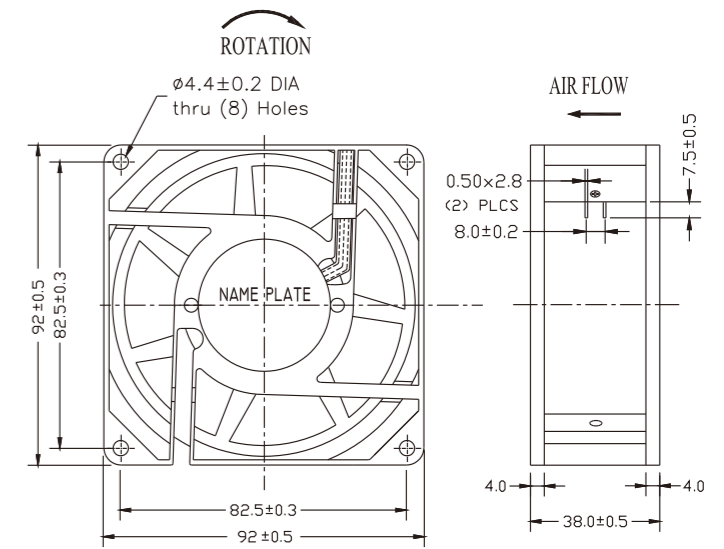
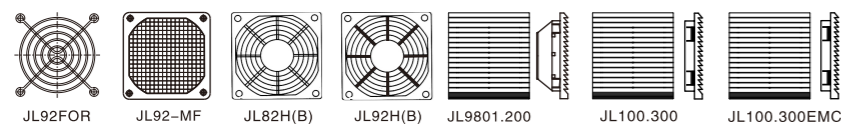

尺寸 Size: 92mm × 92mm × 38mm  
风量 Airflow: 38–46CFM  
重量 Weight: 360g  
噪音 Noise: 26–31dB(A)  
风叶 Impeller Material: PBT UL94–V0 Reinforced Plastic  
外框 Frame: Aluminum Alloy  
端子 Terminals: 0.5mm  
引线 Lead Wire: AWG#22 UL 1569(Optional)  
马达 Motor: Shaded Pole Induction Motor  
温度范围 Operating Temperature: -10°C~+65°C

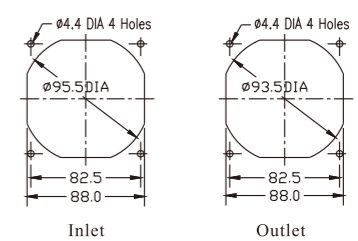

产品型号 Model	轴承型式 Bearing System	电压 Voltage VAC	频率 Freq. Hz	电流 Current A	功率 Power W	转速 Speed RPM	噪音 Noise dB(A)	风量 Air Flow CFM	相数 Phase	电容 Capacitor μF/VAC
G9238HA,S	Sleeve	100/125	50/60	0.23/0.18	17/13	2350/2750	26/31	39/46	1	—
G9238HA <sub>2</sub> S		200/240	50/60	0.06/0.05	10/8	2350/2750	26/31	39/46	1	—
G9238HA,B	Ball	100/125	50/60	0.23/0.18	17/13	2350/2750	26/31	39/46	1	—
G9238HA <sub>2</sub> B		200/240	50/60	0.06/0.05	10/8	2350/2750	26/31	39/46	1	—
G9238MA,S	Sleeve	100/125	50/60	0.12/0.09	9/7	2250/2600	26/28	38/44	1	—
G9238MA <sub>2</sub> S		200/240	50/60	0.07/0.06	11/8	2250/2600	26/28	38/44	1	—
G9238MA,B	Ball	100/125	50/60	0.12/0.09	9/7	2250/2600	26/28	38/44	1	—
G9238MA <sub>2</sub> B		200/240	50/60	0.07/0.06	11/8	2250/2600	26/28	38/44	1	—

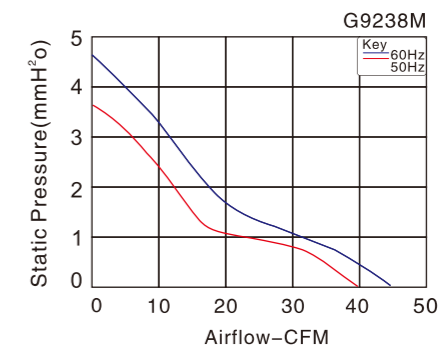
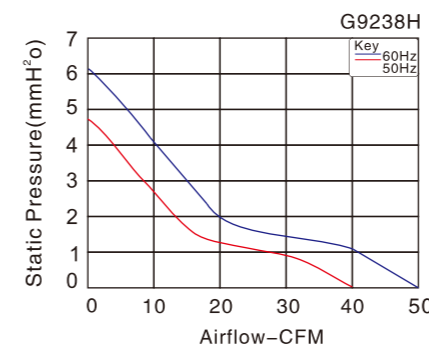

Fan Accessories

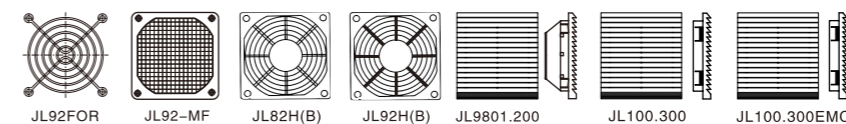

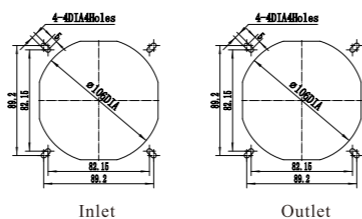
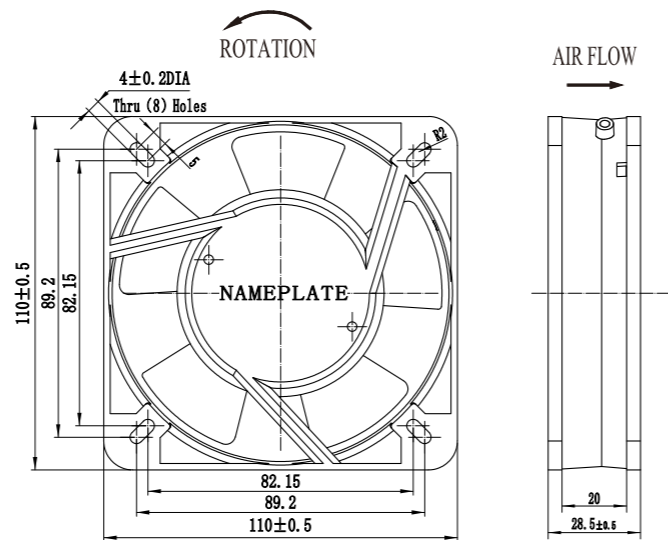

尺寸 Size: 110mm × 110mm × 25mm  
风量 Airflow: 45-71CFM  
重量 Weight: 310g  
噪音 Noise: 27-38dB(A)  
风叶 Impeller Material: PBT UL94-V0 Reinforced Plastic  
外框 Frame: Aluminum Alloy  
端子 Terminals: 0.5mm  
引线 Lead Wire: AWG#22 UL 1569(Optional)  
马达 Motor: Shaded Pole Induction Motor  
温度范围 Operating Temperature: -10°C~+65°C

产品型号 Model	轴承型式 Bearing System	电压 Voltage VAC	频率 Freq. Hz	电流 Current A	功率 Power W	转速 Speed RPM	噪音 Noise dB(A)	风量 Air Flow CFM	相数 Phase	电容 Capacitor μF/VAC
G11025HA <sub>1</sub> S	Sleeve	100/125	50/60	0.25/0.23	22/19	2450/2900	36/38	60/71	1	/
G11025HA <sub>2</sub> S		200/240	50/60	0.1/0.08	17/13	2450/2900	36/38	60/71	1	/
G11025HA <sub>1</sub> B	Ball	100/125	50/60	0.25/0.23	22/19	2450/2900	36/38	60/71	1	/
G11025HA <sub>2</sub> B		200/240	50/60	0.1/0.08	17/13	2450/2900	36/38	60/71	1	/
G11025MA <sub>1</sub> B	Sleeve	100/125	50/60	0.16/0.15	16/15	2000/2000	33/33	52/52	1	/
G11025MA <sub>2</sub> B		200/240	50/60	0.07/0.07	16/15	2000/2000	33/33	52/52	1	/
G11025MA <sub>1</sub> B	Ball	100/125	50/60	0.16/0.15	16/15	2000/2000	33/33	52/52	1	/
G11025MA <sub>2</sub> B		200/240	50/60	0.08/0.08	19/18	2000/2000	33/33	60/71	1	/
G11025LA <sub>1</sub> S	Sleeve	100/125	50/60	0.13/0.11	14/13	1800/1700	28/27	46/45	1	/
G11025LA <sub>2</sub> S		200/240	50/60	0.05/0.05	14/13	1800/1700	28/27	46/45	1	/
G11025LA <sub>1</sub> B	Ball	100/125	50/60	0.13/0.11	14/13	1800/1700	28/27	46/45	1	/
G11025LA <sub>2</sub> B		200/240	50/60	0.05/0.05	14/13	1800/1700	28/27	46/45	1	/

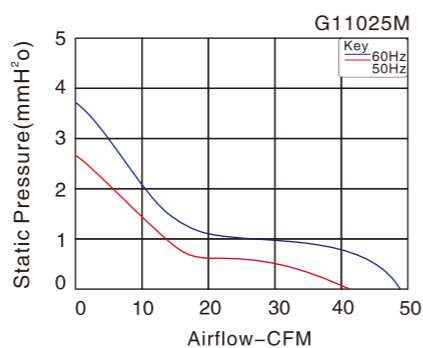
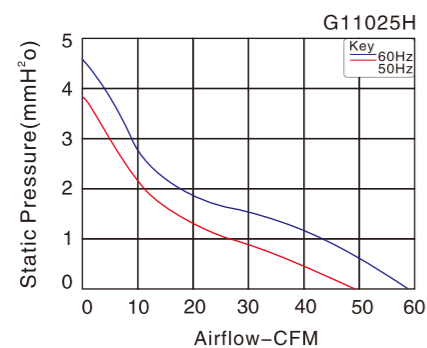

Fan Accessories

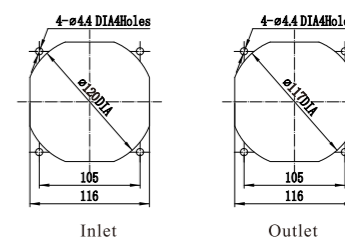
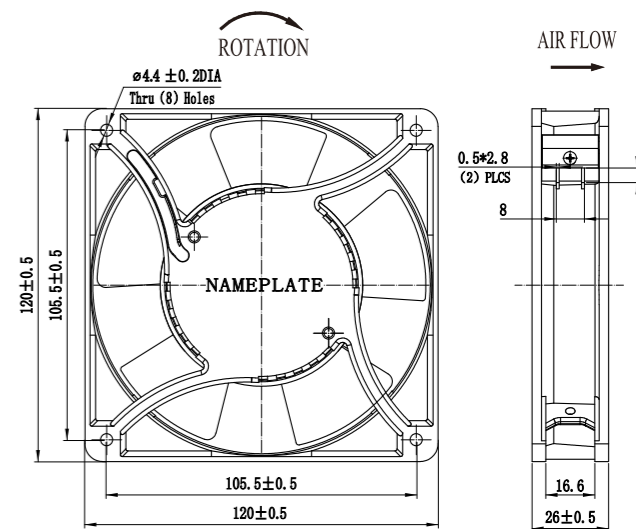
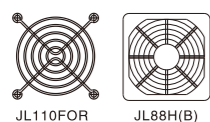

尺寸 Size: 120mm × 120mm × 25mm  
风量 Airflow: 50-78CFM  
重量 Weight: 330g  
噪音 Noise: 30-41dB(A)  
风叶 Impeller Material: PBT UL94-V0 Reinforced Plastic  
外框 Frame: Aluminum Alloy  
端子 Terminals: 0.5mm  
引线 Lead Wire: AWG#22 UL 1569(Optional)  
马达 Motor: Shaded Pole Induction Motor  
温度范围 Operating Temperature: -10°C~+65°C

产品型号 Model	轴承型式 Bearing System	电压 Voltage VAC	频率 Freq. Hz	电流 Current A	功率 Power W	转速 Speed RPM	噪音 Noise dB(A)	风量 Air Flow CFM	相数 Phase	电容 Capacitor μF/VAC
G12025HA <sub>1</sub> S	Sleeve	100/125	50/60	0.30/0.28	28/26	2300/2700	38/41	66/78	1	/
G12025HA <sub>2</sub> S		200/240	50/60	0.1/0.08	17/14	2300/2700	38/41	66/78	1	/
G12025HA <sub>1</sub> B	Ball	100/125	50/60	0.30/0.28	28/26	2300/2700	38/41	66/78	1	/
G12025HA <sub>2</sub> B		200/240	50/60	0.1/0.08	17/14	2300/2700	38/41	66/78	1	/
G12025MA <sub>1</sub> S	Sleeve	100/125	50/60	0.16	16	1800/2300	30/38	50/66	1	/
G12025MA <sub>2</sub> S		200/240	50/60	0.08	16	1800/2300	30/38	50/66	1	/
G12025MA <sub>1</sub> B	Ball	100/125	50/60	0.16	16	1800/2300	30/38	50/66	1	/
G12025MA <sub>2</sub> B		200/240	50/60	0.08	16	1800/2300	30/38	50/66	1	/

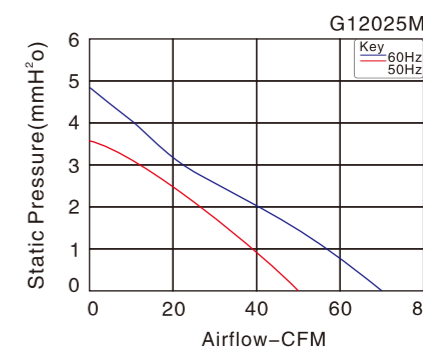
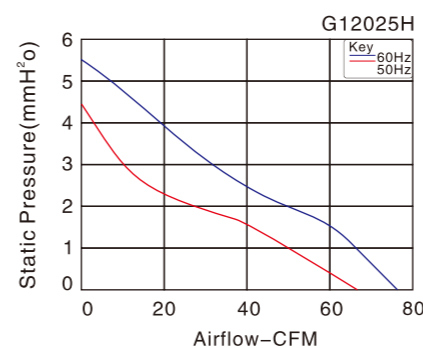

Fan Accessories

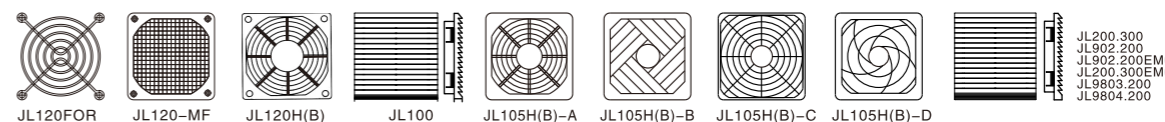

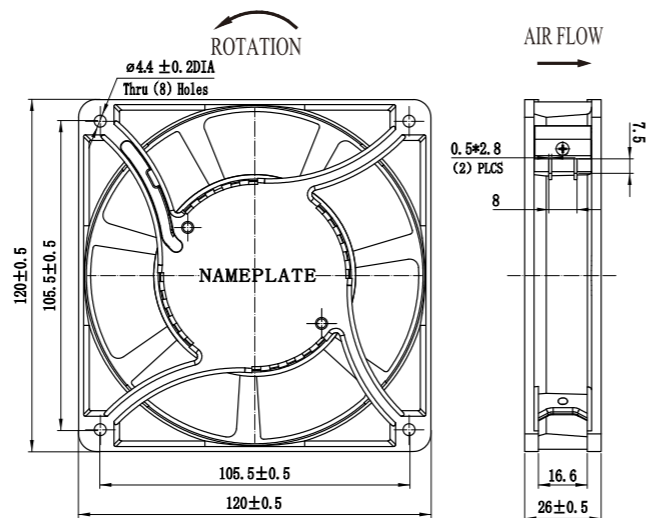

尺寸 Size: 120mm × 120mm × 25mm  
风量 Airflow: 50~76CFM  
重量 Weight: 350g  
噪音 Noise: 31~41dB(A)  
风叶 Impeller Material: PBT UL94-V0 Reinforced Plastic  
外框 Frame: Aluminum Alloy  
端子 Terminals: 0.5mm  
引线 Lead Wire: AWG#22 UL 1569(Optional)  
马达 Motor: Shaded Pole Induction Motor  
温度范围 Operating Temperature: -10°C~+65°C

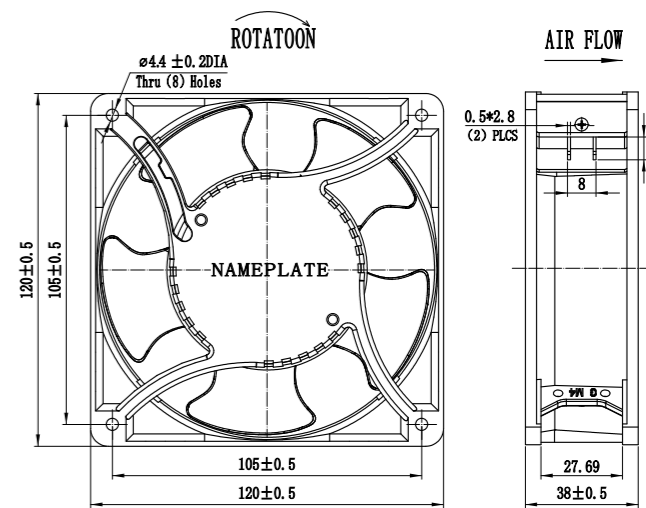
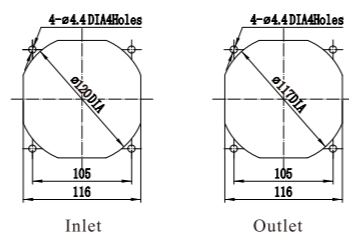

尺寸 Size: 120mm × 120mm × 38mm  
风量 Airflow: 76~98CFM  
重量 Weight: 480g  
噪音 Noise: 39~48dB(A)  
风叶 Impeller Material: PBT UL94-V0 Reinforced Plastic  
外框 Frame: Aluminum Alloy  
端子 Terminals: 0.5mm  
引线 Lead Wire: AWG#22 UL 1569(Optional)  
马达 Motor: Shaded Pole Induction Motor  
温度范围 Operating Temperature: -10°C~+65°C

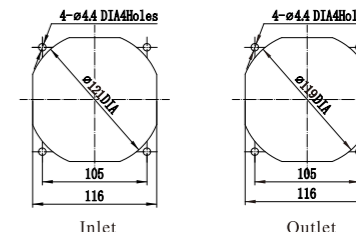

产品型号 Model	轴承型式 Bearing System	电压 Voltage VAC	频率 Freq. Hz	电流 Current A	功率 Power W	转速 Speed RPM	噪音 Noise dB(A)	风量 Air Flow CFM	相数 Phase	电容 Capacitor μF/VAC
G12025HA <sub>1</sub> S-7P	Sleeve	100/125	50/60	0.32/0.28	26/32	2350/2650	34/39	59/68	1	—
G12025HA <sub>2</sub> S-7P		200/240	50/60	0.07	14/13	2350/2650	34/39	59/68	1	—
G12025HA <sub>1</sub> B-7P	Ball	100/125	50/60	0.32/0.28	26/32	2450/2700	39/41	68/76	1	—
G12025HA <sub>2</sub> B-7P		200/240	50/60	0.07	14/13	2450/2700	39/41	68/76	1	—
G12025MA <sub>1</sub> S-7P	Sleeve	100/125	50/60	0.13	11/10	2000/2200	33/34	55/65	1	—
G12025MA <sub>2</sub> S-7P		200/240	50/60	0.06	11/10	2000/2200	33/34	55/65	1	—
G12025MA <sub>1</sub> B-7P	Ball	100/125	50/60	0.13	11/10	2000/2200	33/34	55/65	1	—
G12025MA <sub>2</sub> B-7P		200/240	50/60	0.06	11/10	2000/2200	33/34	55/65	1	—
G12025LA <sub>1</sub> S-7P	Sleeve	100/125	50/60	0.09	9/8	1800/1800	31/31	50/50	1	—
G12025LA <sub>2</sub> S-7P		200/240	50/60	0.05	9/8	1800/1800	31/31	50/50	1	—
G12025LA <sub>1</sub> B-7P	Ball	100/125	50/60	0.09	9/8	1800/1800	31/31	50/50	1	—
G12025LA <sub>2</sub> B-7P		200/240	50/60	0.05	9/8	1800/1800	31/31	50/50	1	—

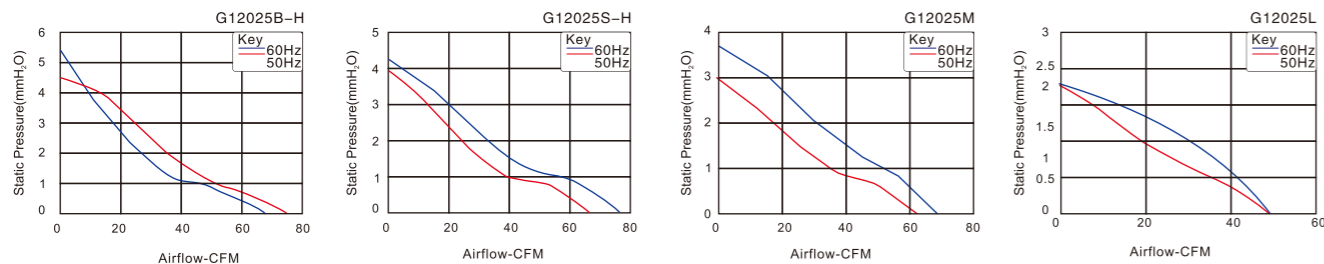

Fan Accessories

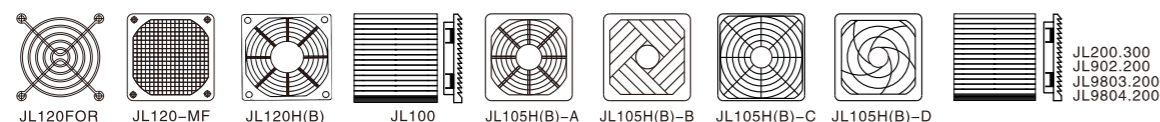

产品型号 Model	轴承型式 Bearing System	电压 Voltage VAC	频率 Freq. Hz	电流 Current A	功率 Power W	转速 Speed RPM	噪音 Noise dB(A)	风量 Air Flow CFM	相数 Phase	电容 Capacitor μF/VAC
G12038HA <sub>1</sub> S	Sleeve	100/125	50/60	0.4/0.33	23/30	2600/3000	43/48	93/98	1	—
G12038HA <sub>2</sub> S		200/240	50/60	0.15/0.12	21/18	2600/3000	43/48	93/98	1	—
G12038HA <sub>3</sub> S		380/420	50/60	0.1	21	2600/3000	43/48	93/98	1	—
G12038HA <sub>1</sub> B	Ball	100/125	50/60	0.4/0.33	23/30	2600/3000	43/48	93/98	1	—
G12038HA <sub>2</sub> B		200/240	50/60	0.15/0.12	21/18	2600/3000	43/48	93/98	1	—
G12038HA <sub>3</sub> B		380/420	50/60	0.1	21	2600/3000	43/48	93/98	1	—
G12038MA <sub>1</sub> S	Sleeve	100/125	50/60	0.24	18	2200/2600	39/44	76/94	1	—
G12038MA <sub>2</sub> S		200/240	50/60	0.11	19	2200/2600	39/44	76/94	1	—
G12038MA <sub>1</sub> B	Ball	100/125	50/60	0.22	19	2200/2600	39/44	76/94	1	—
G12038MA <sub>2</sub> B		200/240	50/60	0.11	19	2200/2600	39/44	76/94	1	—

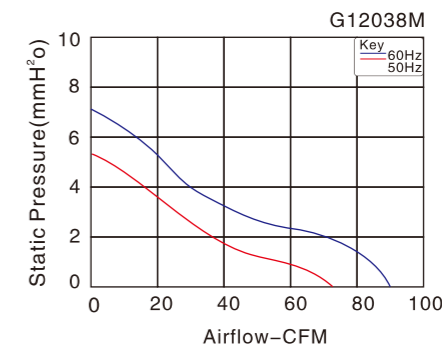
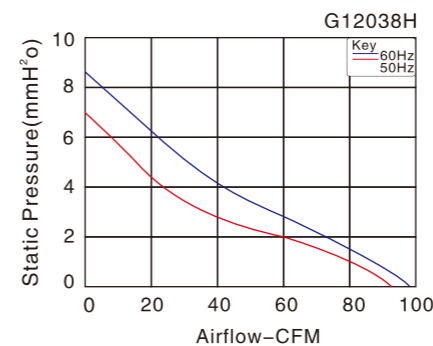

Fan Accessories

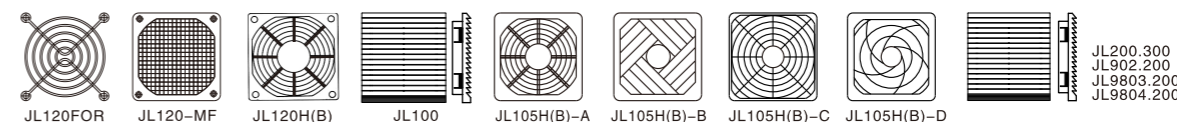

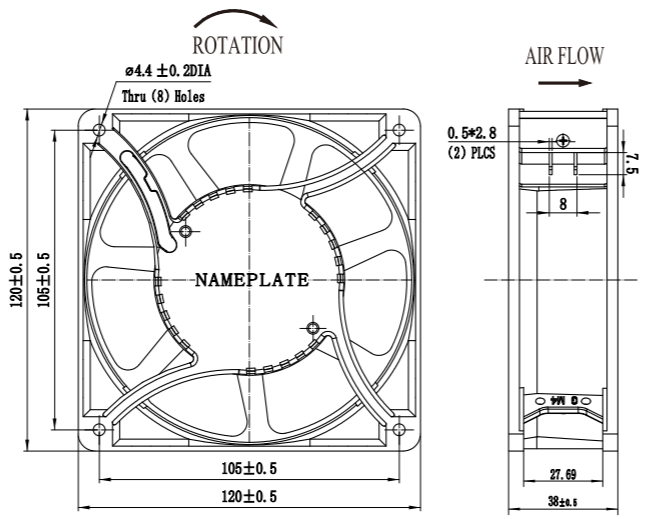

尺寸 Size: 120mm x 120mm x 38mm  
风量 Airflow: 78-112CFM  
重量 Weight: 490g  
噪音 Noise: 35-44dB(A)  
风叶 Impeller Material: PBT UL94-V0 Reinforced Plastic  
外框 Frame: Aluminum Alloy  
端子 Terminals: 0.5mm  
引线 Lead Wire: AWG#22 UL 1569(Optional)  
马达 Motor: Shaded Pole Induction Motor  
温度范围 Operating Temperature: -10°C~+65°C

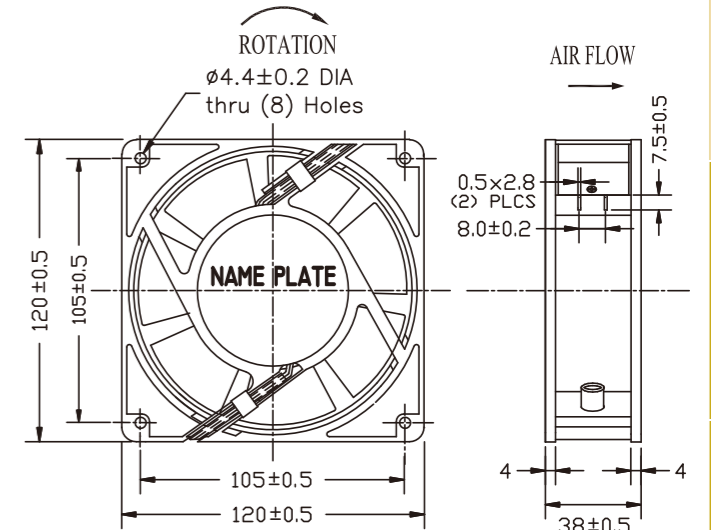
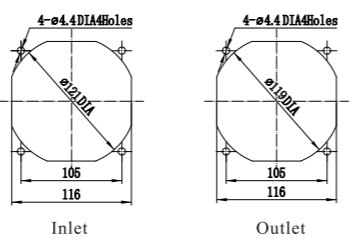

尺寸 Size: 120mm x 120mm x 38mm  
风量 Airflow: 93-126CFM  
重量 Weight: 510g  
噪音 Noise: 43-50dB(A)  
风叶 Impeller Material: PBT UL94-V0 Reinforced Plastic  
外框 Frame: Aluminum Alloy  
端子 Terminals: 0.5mm  
引线 Lead Wire: AWG#22 UL 1569(Optional)  
马达 Motor: Capacitor-Run Induction Motor  
温度范围 Operating Temperature: -10°C~+65°C

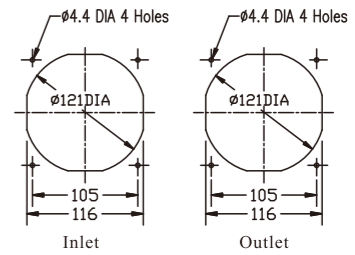

产品型号 Model	轴承型式 Bearing System	电压 Voltage VAC	频率 Freq. Hz	电流 Current A	功率 Power W	转速 Speed RPM	噪音 Noise dB(A)	风量 Air Flow CFM	相数 Phase	电容 Capacitor μF/VAC
G12038HA,S-7P	Sleeve	100/125	50/60	0.30	31/23	2600/3000	39/44	99/112	1	—
G12038HA,S-7P		200/240	50/60	0.18/0.15	25/26	2600/3000	39/44	99/112	1	—
G12038HA,B-7P	Ball	100/125	50/60	0.30	29/24	2600/3000	39/44	99/112	1	—
G12038HA,B-7P		200/240	50/60	0.18/0.15	25/26	2600/3000	39/44	99/112	1	—
G12038MA,S-7P	Sleeve	100/125	50/60	0.25	19/17	2450/2700	38/42	91/100	1	—
G12038MA,S-7P		200/240	50/60	0.16	16/15	2450/2700	38/42	91/100	1	—
G12038MA,B-7P	Ball	100/125	50/60	0.25	19/17	2450/2700	39/42	91/100	1	—
G12038MA,B-7P		200/240	50/60	0.16	16/15	2450/2700	39/42	91/100	1	—
G12038LA,S-7P	Sleeve	100/125	50/60	0.20	14/13	2100/2400	35/40	78/91	1	—
G12038LA,S-7P		200/240	50/60	0.10	12/11	2100/2450	35/40	78/91	1	—
G12038LA,B-7P	Ball	100/125	50/60	0.20	14/13	2100/2450	35/38	78/91	1	—
G12038LA,B-7P		200/240	50/60	0.10	12/11	2100/2450	35/38	78/91	1	—

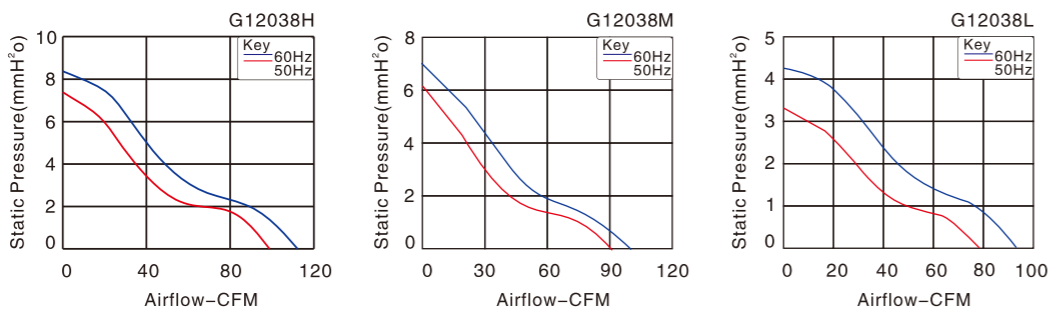

Fan Accessories

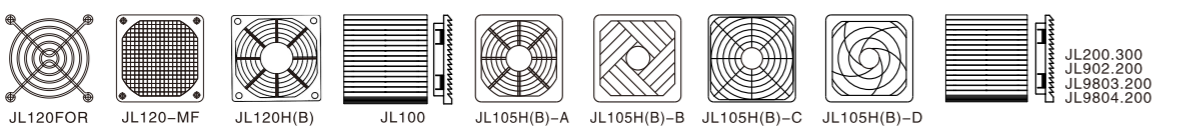

产品型号 Model	轴承型式 Bearing System	电压 Voltage VAC	频率 Freq. Hz	电流 Current A	功率 Power W	转速 Speed RPM	噪音 Noise dB(A)	风量 Air Flow CFM	相数 Phase	电容 Capacitor μF/VAC
G12038HA,S-C-7P	Sleeve	100/125	50/60	0.17/0.18	24/23	2700/3200	46/50	100/119	1	3.3/250
G12038HA,S-C-7P		200/240	50/60	0.10/0.11	21/21	2700/3200	46/50	100/119	1	0.47/500
G12038HA,B-C-7P	Ball	100/125	50/60	0.17/0.18	23/22	2850/3400	45/49	105/126	1	3.3/250
G12038HA,B-C-7P		200/240	50/60	0.10/0.11	20/20	2850/3400	45/49	105/126	1	0.47/500
G12038MA,S-C-7P	Sleeve	100/125	50/60	0.15/0.16	14/14	2550/2800	43/46	93/105	1	3.3/250
G12038MA,S-C-7P		200/240	50/60	0.08/0.09	13/14	2550/2800	43/46	93/105	1	0.47/500
G12038MA,B-C-7P	Ball	100/125	50/60	0.15/0.16	14/14	2550/2800	43/46	93/105	1	3.3/500
G12038MA,B-C-7P		200/240	50/60	0.08/0.09	13/14	2550/2800	43/46	93/105	1	0.47/500

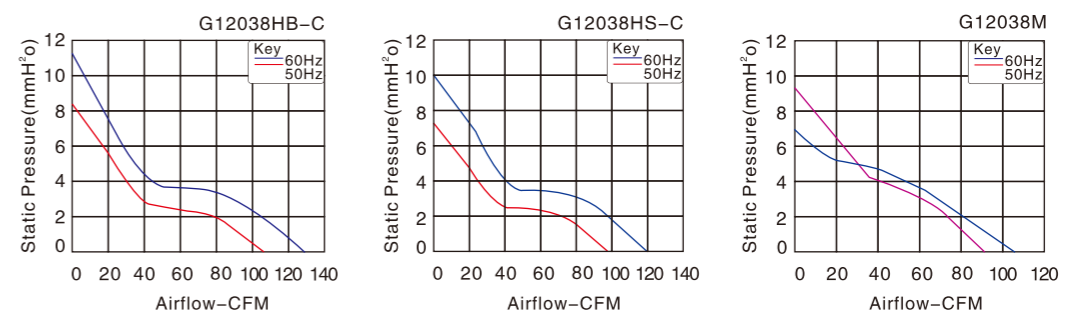

Fan Accessories

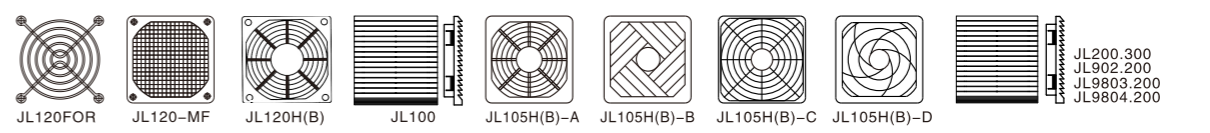

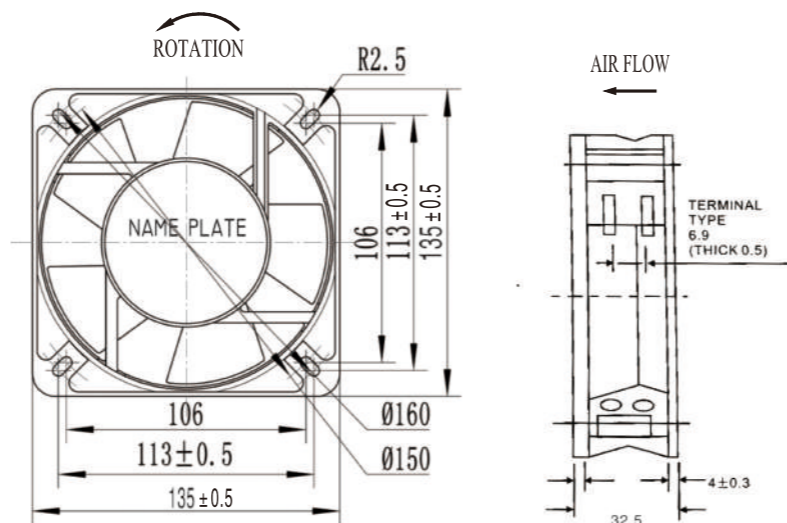

尺寸 Size: 135mm × 135mm × 32mm  
风量 Airflow: 110–115CFM  
重量 Weight: 595g  
噪音 Noise: 44–50dB(A)  
风叶 Impeller Material: PBT UL94–V0 Reinforced Plastic  
外框 Frame: Aluminum Alloy  
端子 Terminals: 0.5mm  
引线 Lead Wire: AWG#22 UL 1569(Optional)  
马达 Motor: Shaded Pole Induction Motor  
温度范围 Operating Temperature: -10°C~+65°C

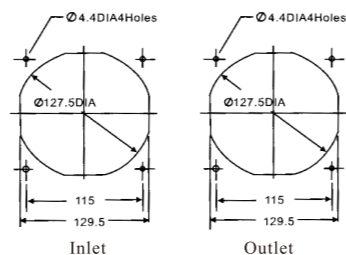

产品型号 Model	轴承型式 Bearing System	电压 Voltage VAC	频率 Freq. Hz	电流 Current A	功率 Power W	转速 Speed RPM	噪音 Noise dB(A)	风量 Air Flow CFM	相数 Phase	电容 Capacitor µF/VAC
G13532HA,B	Ball	100/125	50/60	0.34	27/23	2500/2800	44/50	110/115	1	—
G13532HA <sub>2</sub> B	Ball	200/240	50/60	0.17	27/23	2500/2800	44/50	110/115	1	—
G13532HA <sub>3</sub> B	Ball	380/420	50/60	0.10	32/28	2500/2800	44/50	110/115	1	—

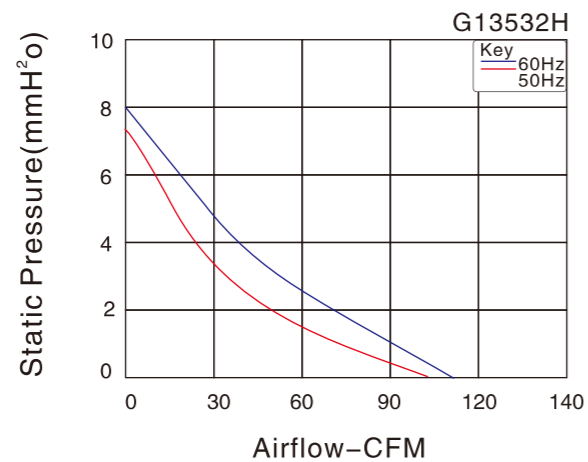

Fan Accessories

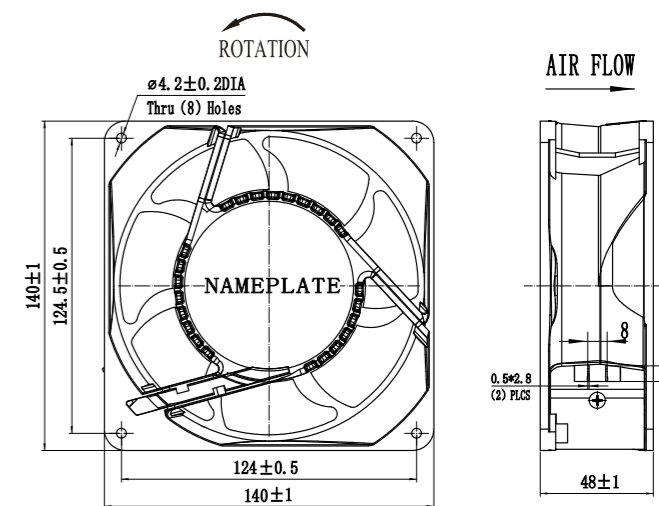
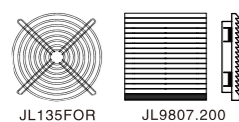

尺寸 Size: 140mm × 140mm × 45mm  
风量 Airflow: 140–185CFM  
重量 Weight: 815g  
噪音 Noise: 44–56dB(A)  
风叶 Impeller Material: PBT UL94–V0 Reinforced Plastic  
外框 Frame: Aluminum Alloy  
端子 Terminals: 0.5mm  
引线 Lead Wire: AWG#22 UL 1569(Optional)  
马达 Motor: Capacitor-Run Induction Motor  
温度范围 Operating Temperature: -10°C~+65°C

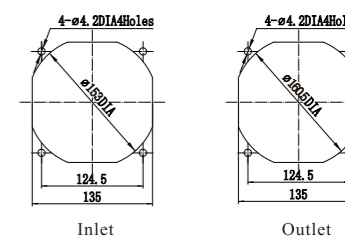

产品型号 Model	轴承型式 Bearing System	电压 Voltage VAC	频率 Freq. Hz	电流 Current A	功率 Power W	转速 Speed RPM	噪音 Noise dB(A)	风量 Air Flow CFM	相数 Phase	电容 Capacitor µF/VAC
G14045HA,B-C	Ball	100/125	50/60	0.25/0.27	35	2800/3400	48/56	160/185	1	3.3/250
G14045HA <sub>2</sub> B-C		200/240	50/60	0.12/0.15	27/29	2800/3300	48/56	160/185	1	1/500
G14045MA,B-C	Ball	100/125	50/60	0.23/0.25	28	2400/2800	44/50	140/160	1	3.3/250
G14045MA <sub>2</sub> B-C		200/240	50/60	0.14	28	2400/2800	44/50	140/160	1	1/500
G14045MA <sub>3</sub> B-C		380	50/60	0.14	20/22	2700/3000	47/52	140/160	1	0.33/500

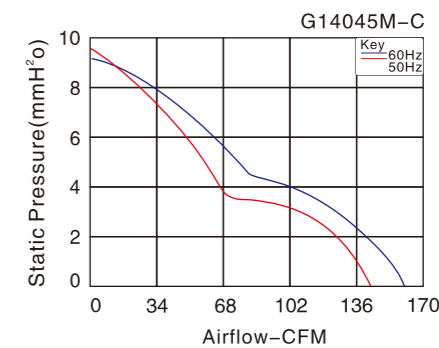
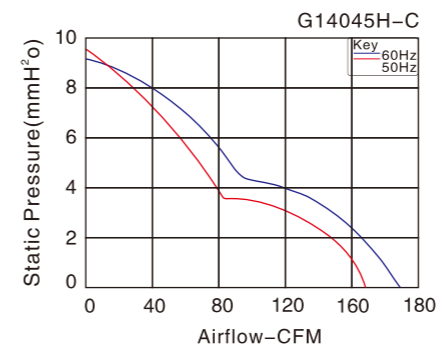

Fan Accessories



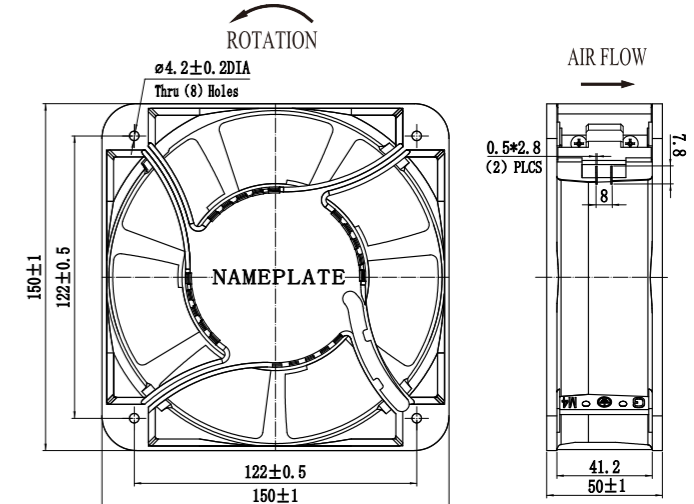
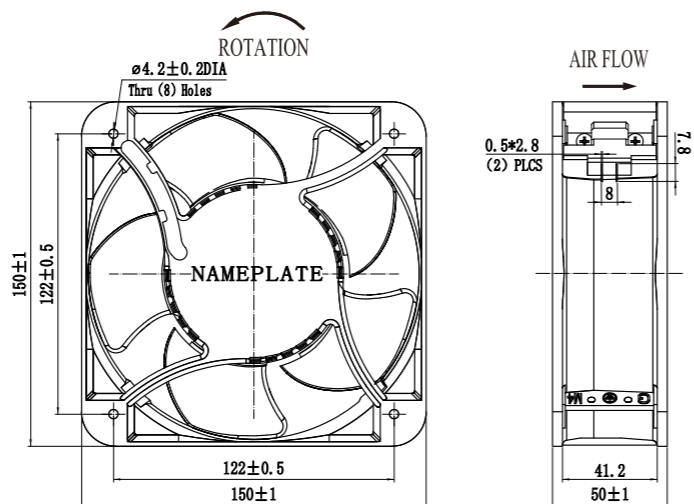

尺寸 Size: 150mm × 150mm × 50mm  
风量 Airflow: 170~210CFM  
重量 Weight: 850g  
噪音 Noise: 49~59dB(A)  
风叶 Impeller Material: PBT UL94-V0 Reinforced Plastic  
外框 Frame: Aluminum Alloy  
端子 Terminals: 0.5mm  
引线 Lead Wire: AWG#22 UL 1569(Optional)  
马达 Motor: Shaded Pole Induction Motor  
温度范围 Operating Temperature: -10°C~+65°C

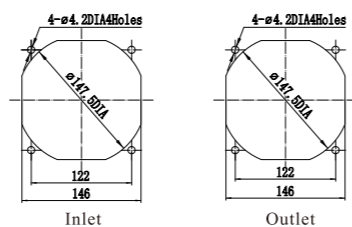

尺寸 Size: 150mm × 150mm × 50mm  
风量 Airflow: 170~210CFM  
重量 Weight: 843g  
噪音 Noise: 49~59dB(A)  
风叶 Impeller Material: PBT UL94-V0 Reinforced Plastic  
外框 Frame: Aluminum Alloy  
端子 Terminals: 0.5mm  
引线 Lead Wire: AWG#22 UL 1569(Optional)  
马达 Motor: Shaded Pole Induction Motor  
温度范围 Operating Temperature: -10°C~+65°C

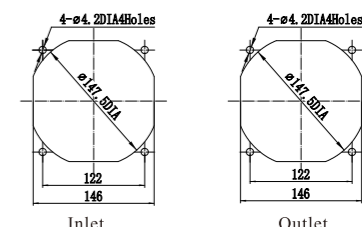

产品型号 Model	轴承型式 Bearing System	电压 Voltage VAC	频率 Freq. Hz	电流 Current A	功率 Power W	转速 Speed RPM	噪音 Noise dB(A)	风量 Air Flow CFM	相数 Phase	电容 Capacitor μF/VAC
G15050HA <sub>1</sub> S	Sleeve	100/125	50/60	0.40	38	2600/2900	53/59	190/210	1	/
G15050HA <sub>2</sub> S		200/240	50/60	0.19	25	2600/2900	53/59	190/210	1	/
G15050HA <sub>3</sub> S		380/420	50/60	0.12	38	2600/2900	53/59	190/210	1	/
G15050HA <sub>1</sub> B	Ball	100/125	50/60	0.40	38	2600/2900	53/59	190/210	1	/
G15050HA <sub>2</sub> B		200/240	50/60	0.19	25	2600/2900	53/59	190/210	1	/
G15050HA <sub>3</sub> B		380/420	50/60	0.12	38	2600/2900	53/59	190/210	1	/
G15050MA <sub>1</sub> S	Sleeve	100/125	50/60	0.35	35	2200/2600	49/54	170/190	1	/
G15050MA <sub>2</sub> S		200/240	50/60	0.19	35	2200/2600	49/54	170/190	1	/
G15050MA <sub>3</sub> S		380/420	50/60	0.12	35	2200/2600	49/54	170/190	1	/
G15050MA <sub>1</sub> B	Ball	100/125	50/60	0.35	35	2200/2600	49/54	170/190	1	/
G15050MA <sub>2</sub> B		200/240	50/60	0.19	35	2200/2600	49/54	170/190	1	/
G15050MA <sub>3</sub> B		380/420	50/60	0.05/0.07	22/18	2350/2600	49/54	170/190	1	/

产品型号 Model	轴承型式 Bearing System	电压 Voltage VAC	频率 Freq. Hz	电流 Current A	功率 Power W	转速 Speed RPM	噪音 Noise dB(A)	风量 Air Flow CFM	相数 Phase	电容 Capacitor μF/VAC
G15050HA <sub>1</sub> S-7P	Sleeve	100/125	50/60	0.40	38	2600/2900	53/59	190/210	1	/
G15050HA <sub>2</sub> S-7P		200/240	50/60	0.22	38	2600/2900	53/59	190/210	1	/
G15050HA <sub>3</sub> S-7P		380/420	50/60	0.12	38	2600/2900	53/59	190/210	1	/
G15050HA <sub>1</sub> B-7P	Ball	100/125	50/60	0.04/0.34	32/25	2600/2900	53/59	190/210	1	/
G15050HA <sub>2</sub> B-7P		200/240	50/60	0.18/0.17	27/24	2600/2900	53/59	190/210	1	/
G15050HA <sub>3</sub> B-7P		380/420	50/60	0.12	30	2600/2900	53/59	190/210	1	/
G15050MA <sub>1</sub> S-7P	Sleeve	100/125	50/60	0.35	35	2200/2600	49/54	170/190	1	/
G15050MA <sub>2</sub> S-7P		200/240	50/60	0.19	35	2200/2600	49/54	170/190	1	/
G15050MA <sub>3</sub> S-7P		380/420	50/60	0.12	35	2200/2600	49/54	170/190	1	/
G15050MA <sub>1</sub> B-7P	Ball	100/125	50/60	0.35	35	2200/2600	49/54	170/190	1	/
G15050MA <sub>2</sub> B-7P		200/240	50/60	0.19	35	2200/2600	49/54	170/190	1	/
G15050MA <sub>3</sub> B-7P		380/420	50/60	0.05/0.07	22/18	2350/2600	49/54	170/190	1	/

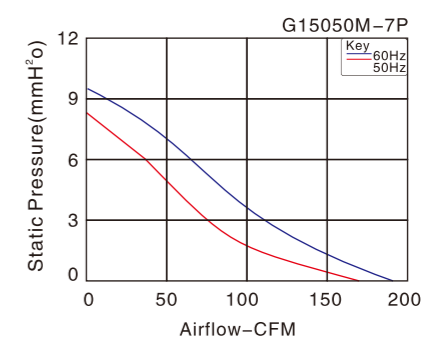
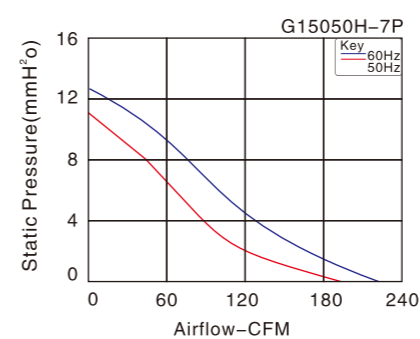
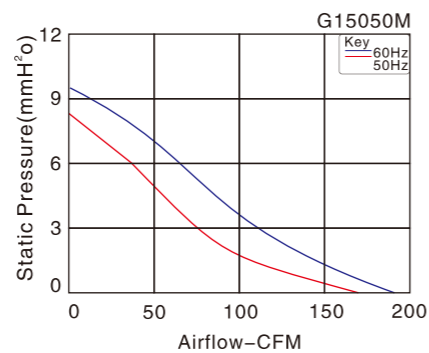
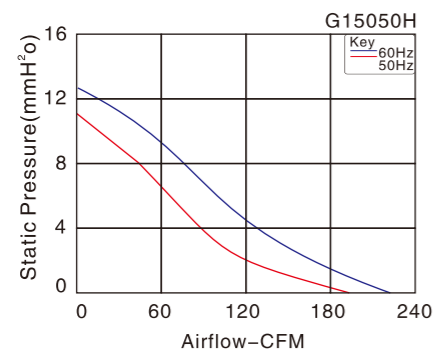

Fan Accessories

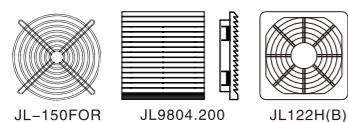

Fan Accessories

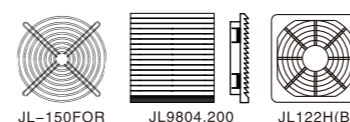

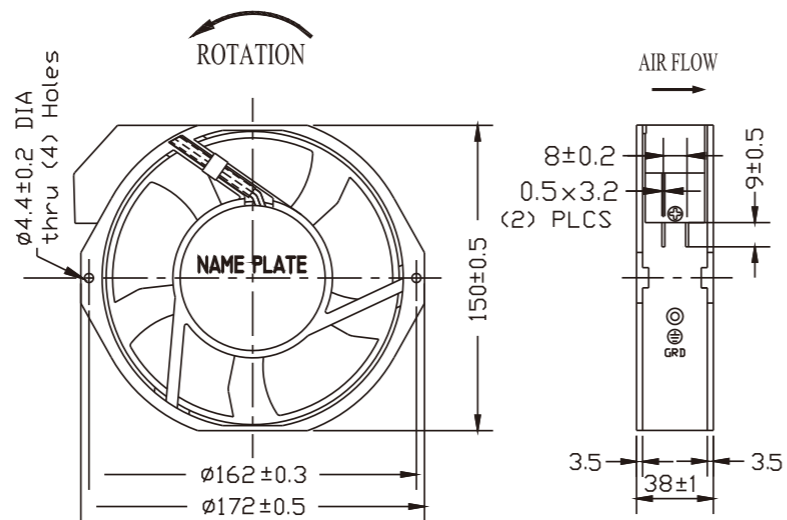

尺寸 Size: 172mm x 150mm x 38mm  
风量 Airflow: 85-230CFM  
重量 Weight: 750g  
噪音 Noise: 38-58dB(A)  
风叶 Impeller Material: PBT UL94-V0 Reinforced Plastic  
外框 Frame: Aluminum Alloy  
端子 Terminals: 0.5mm  
引线 Lead Wire: AWG#22 UL 1569(Optional)  
马达 Motor: Capacitor-Run Induction Motor  
温度范围 Operating Temperature:  $-10^{\circ}\text{C} \sim +65^{\circ}\text{C}$

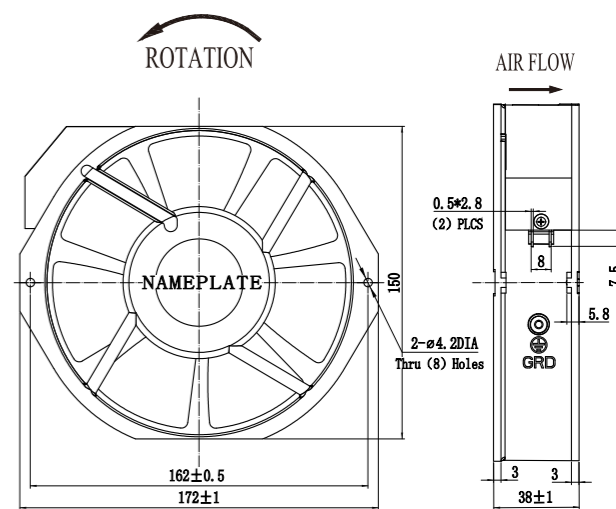
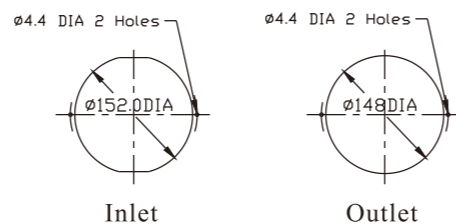

尺寸 Size: 172mm x 150mm x 39mm  
风量 Airflow: 216-240CFM  
重量 Weight: 680g  
噪音 Noise: 56-60dB(A)  
风叶 Impeller Material: PBT UL94-V0 Reinforced Plastic  
外框 Frame: Aluminum Alloy  
端子 Terminals: 0.5mm  
引线 Lead Wire: AWG#22 UL 1569(Optional)  
马达 Motor: Capacitor-Run Induction Motor  
温度范围 Operating Temperature:  $-10^{\circ}\text{C} \sim +65^{\circ}\text{C}$

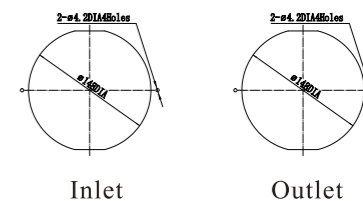

产品型号 Model	轴承型式 Bearing System	电压 Voltage VAC	频率 Freq. Hz	电流 Current A	功率 Power W	转速 Speed RPM	噪音 Noise dB(A)	风量 Air Flow CFM	相数 Phase	电容 Capacitor $\mu\text{F/VAC}$
G17040HA,B-C	Ball	100/125	50/60	0.35/0.33	34/33	2850/3300	54/58	185/211	1	3.3/250
G17040HA <sub>2</sub> B-C		200/240	50/60	0.13/0.13	27/28	2850/3300	54/58	195/230	1	0.75/500
G17040HA <sub>3</sub> B-C		380/420	50/60	0.08/0.09	31/36	2850/3300	54/58	195/230	3	0.75/500
G17040MA,B-C	Ball	100/125	50/60	0.17/0.18	28/29	2500/2800	52/57	146/165	1	1/500
G17040MA <sub>2</sub> B-C		200/240	50/60	0.11/0.12	28/29	2500/2800	52/57	146/165	1	0.47/630
G17040MA <sub>3</sub> B-C		380/420	50/60	0.17/0.18	28/27	2500/2800	52/57	146/165	1	0.47/500
G17040LA,B-C	Ball	100/125	50/60	0.17/0.15	29/28	1400/1700	38/44	85/103	1	0.47/630
G17040LA <sub>3</sub> B-C		200/240	50/60	0.08/0.07	27/26	1400/1700	38/44	85/103	1	/

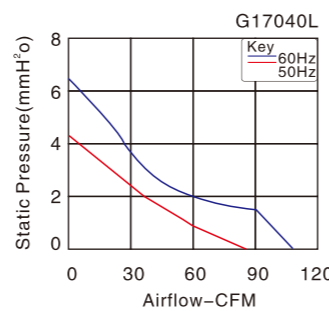
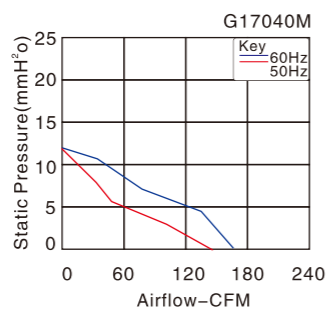
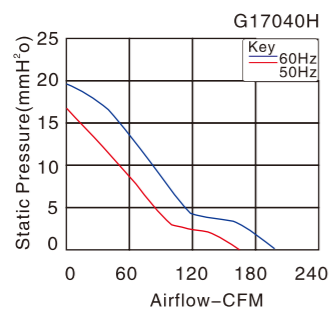

Fan Accessories

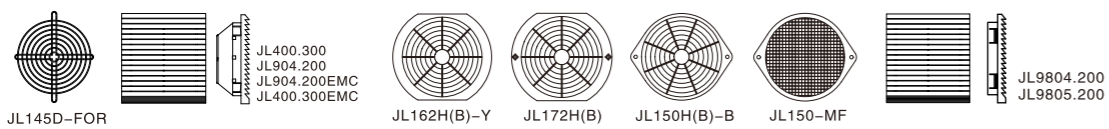

Fan Accessories

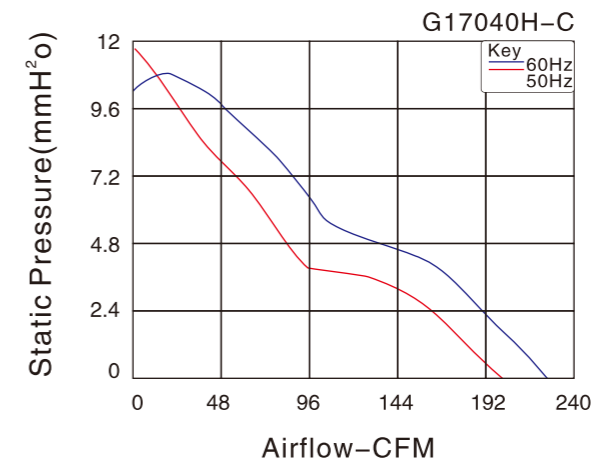
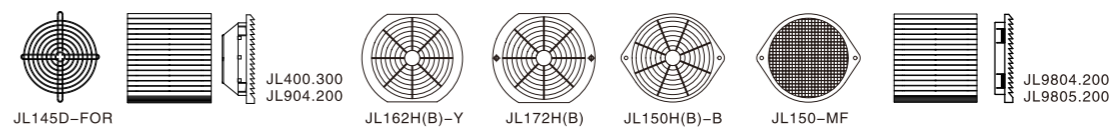

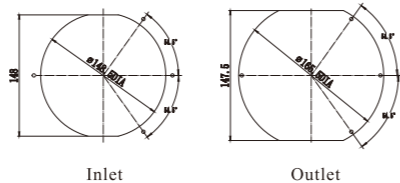
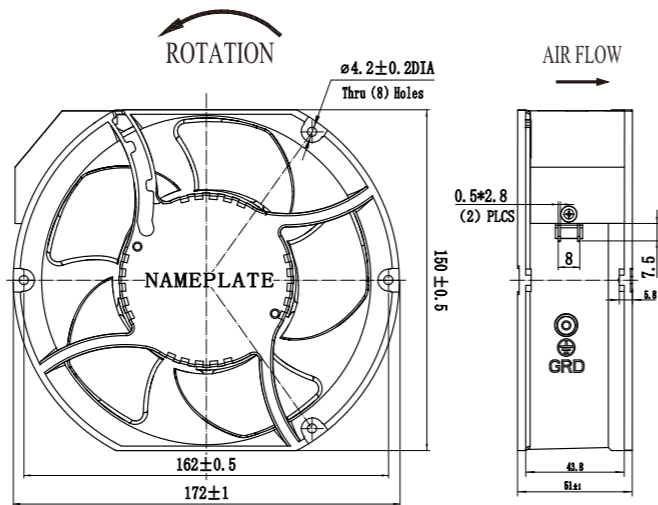

尺寸 Size: 172mm × 150mm × 51mm  
风量 Airflow: 105–235CFM  
重量 Weight: 820g  
噪音 Noise: 30–50dB(A)  
风叶 Impeller Material: PBT UL94–V0 Reinforced Plastic  
外框 Frame: Aluminum Alloy  
端子 Terminals: 0.5mm  
引线 Lead Wire: AWG#22 UL 1569(Optional)  
马达 Motor: Shaded Pole Induction Motor  
温度范围 Operating Temperature: –10°C~+65°C

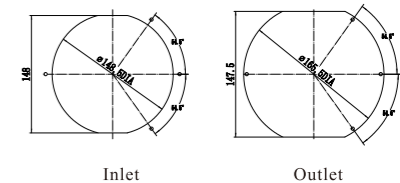
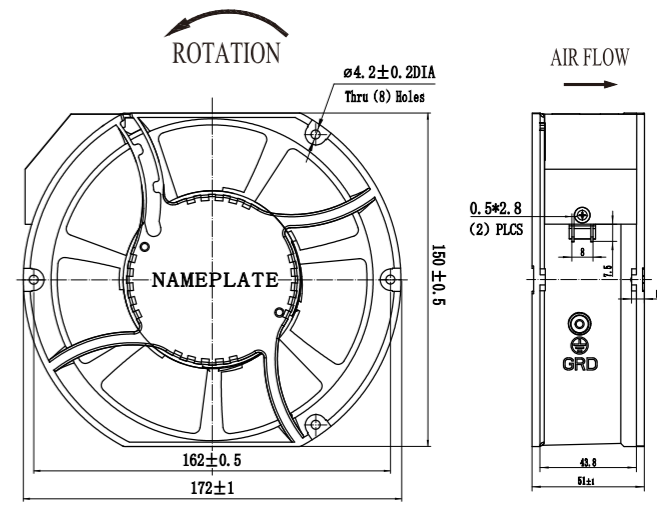

尺寸 Size: 172mm × 150mm × 51mm  
风量 Airflow: 115–245CFM  
重量 Weight: 850g  
噪音 Noise: 30–52dB(A)  
风叶 Impeller Material: PBT UL94–V0 Reinforced Plastic  
外框 Frame: Aluminum Alloy  
端子 Terminals: 0.5mm  
引线 Lead Wire: AWG#22 UL 1569(Optional)  
马达 Motor: Shaded Pole Induction Motor  
温度范围 Operating Temperature: –10°C~+65°C

产品型号 Model	轴承型式 Bearing System	电压 Voltage VAC	频率 Freq. Hz	电流 Current A	功率 Power W	转速 Speed RPM	噪音 Noise dB(A)	风量 Air Flow CFM	相数 Phase	电容 Capacitor μF/VAC
G17050HA,S	Sleeve	100/125	50/60	0.50/0.45	37/36	2700/3100	45/50	190/235	1	—
G17050HA,S		200/240	50/60	0.22/0.21	34/33	2700/3100	45/50	190/235	1	—
G17050HA,S		380/420	50	0.11	34	2700	45	190	1	—
G17050HA,B	Ball	100/125	50/60	0.50/0.45	37/36	2700/3100	45/50	190/235	1	—
G17050HA,B		200/240	50/60	0.22/0.21	34/33	2700/3100	45/50	190/235	1	—
G17050HA,B		380/420	50	0.11	34	2700	45	190	1	—
G17050MA,S	Sleeve	100/125	50/60	0.41/0.39	32/30	2400/2300	41/40	170/160	1	—
G17050MA,S		200/240	50/60	0.19/0.18	30/28	2400/2300	41/40	170/160	1	—
G17050MA,S		380/420	50	0.09	30	2400	41	170	1	—
G17050MA,B	Ball	100/125	50/60	0.41/0.39	32/30	2400/2300	41/40	170/160	1	—
G17050MA,B		200/240	50/60	0.19/0.18	30/28	2400/2300	41/40	170/160	1	—
G17050MA,B		380/420	50	0.09	30	2400	41	170	1	—
G17050LA,S	Sleeve	100/125	50/60	0.35/0.35	26/25	1900/1500	32/30	125/105	1	—
G17050LA,S		200/240	50/60	0.16/0.16	26/25	1900/1500	32/30	125/105	1	—
G17050LA,S		380/420	50	0.07	26	1900	32	125	1	—
G17050LA,B	Ball	100/125	50/60	0.35/0.35	26/25	1900/1500	32/30	125/105	1	—
G17050LA,S		200/240	50/60	0.16/0.16	26/25	1900/1500	32/30	125/105	1	—
G17050LA,B		380/420	50	0.07	26	1900	32	125	1	—

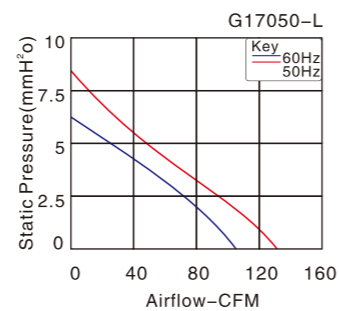
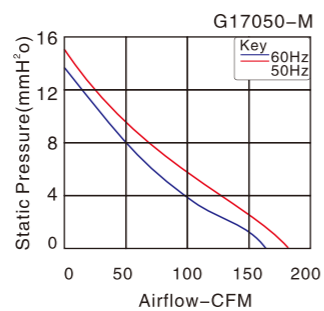
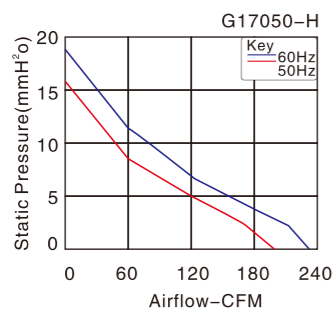

产品型号 Model	轴承型式 Bearing System	电压 Voltage VAC	频率 Freq. Hz	电流 Current A	功率 Power W	转速 Speed RPM	噪音 Noise dB(A)	风量 Air Flow CFM	相数 Phase	电容 Capacitor μF/VAC
G17050HA,S-7P	Sleeve	100/125	50/60	0.50/0.45	37/36	2600/3000	46/52	200/245	1	—
G17050HA,S-7P		200/240	50/60	0.22/0.21	34/33	2600/3000	46/52	200/245	1	—
G17050HA,S-7P		380/420	50	0.11	34	2600	46	200	1	—
G17050HA,B-7P	Ball	100/125	50/60	0.50/0.45	37/36	2600/3000	46/52	200/245	1	—
G17050HA,B-7P		200/240	50/60	0.22/0.21	34/33	2600/3000	46/52	200/245	1	—
G17050HA,B-7P		380/420	50	0.11	34	2600	46	200	1	—
G17050MA,S-7P	Sleeve	100/125	50/60	0.41/0.39	32/30	2400/2300	43/42	178/166	1	—
G17050MA,S-7P		200/240	50/60	0.19/0.18	30/28	2400/2300	43/42	178/166	1	—
G17050MA,S-7P		380/420	50	0.09	30	2400	43	178	1	—
G17050MA,B-7P	Ball	100/125	50/60	0.41/0.39	32/30	2400/2300	43/42	178/166	1	—
G17050MA,B-7P		200/240	50/60	0.19/0.18	30/28	2400/2300	43/42	178/166	1	—
G17050MA,B-7P		380/420	50	0.09	30	2400	43	178	1	—
G17050LA,S-7P	Sleeve	100/125	50/60	0.35/0.35	26/25	1900/1500	35/30	130/115	1	—
G17050LA,S-7P		200/240	50/60	0.16/0.16	26/25	1900/1500	35/30	130/115	1	—
G17050LA,S-7P		380/420	50	0.07	26	1900	35	130	1	—
G17050LA,B-7P	Ball	100/125	50/60	0.35/0.35	26/25	1900/1500	35/30	130/115	1	—
G17050LA,B-7P		200/240	50/60	0.16/0.16	26/25	1900/1500	35/30	130/115	1	—
G17050LA,B-7P		380/420	50	0.07	26	1900	35	130	1	—

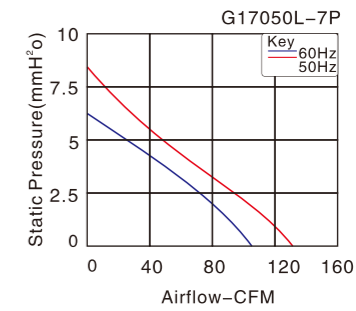
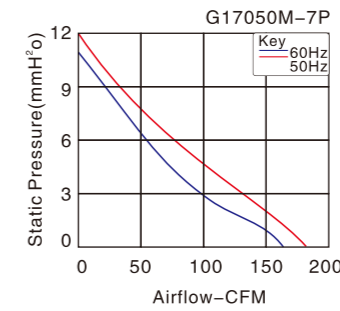
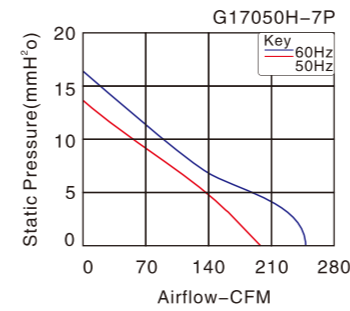

Fan Accessories

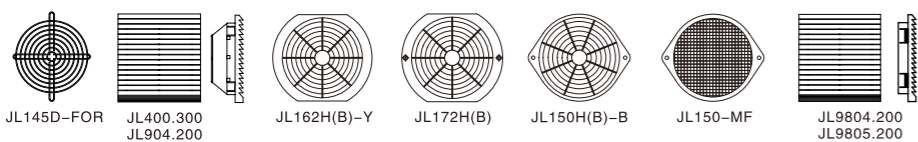

Fan Accessories

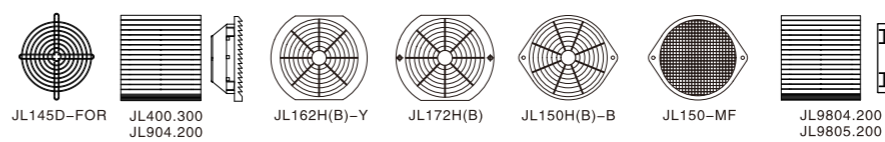

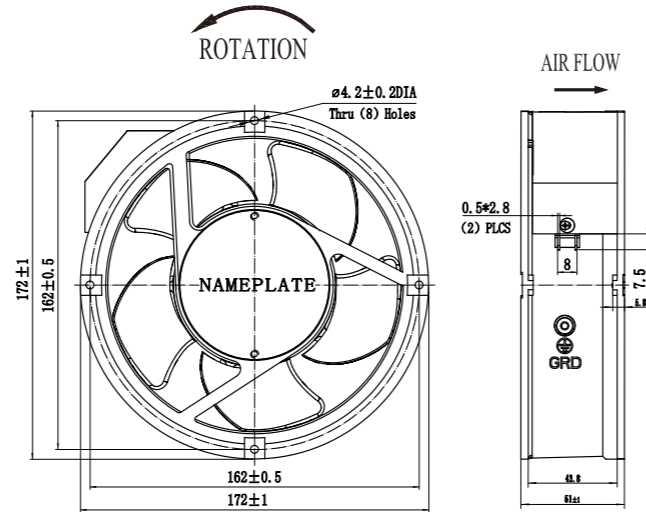

尺寸 Size: Ø172mm × 51mm  
风量 Airflow: 105–235CFM  
重量 Weight: 840g  
噪音 Noise: 30–50dB(A)  
风叶 Impeller Material: PBT UL94–V0 Reinforced Plastic  
外框 Frame: Aluminum Alloy  
端子 Terminals: 0.5mm  
引线 Lead Wire: AWG#22 UL 1569(Optional)  
马达 Motor: Shaded Pole Induction Motor  
温度范围 Operating Temperature: –10°C~+65°C

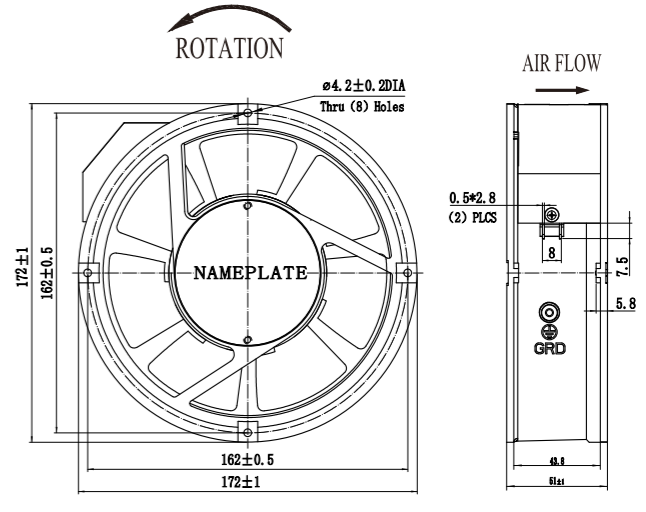
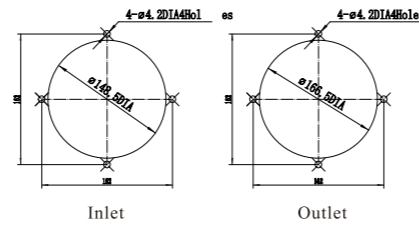

尺寸 Size: Ø172mm × 51mm  
风量 Airflow: 115–245CFM  
重量 Weight: 850g  
噪音 Noise: 32–52dB(A)  
风叶 Impeller Material: PBT UL94–V0 Reinforced Plastic  
外框 Frame: Aluminum Alloy  
端子 Terminals: 0.5mm  
引线 Lead Wire: AWG#22 UL 1569(Optional)  
马达 Motor: Shaded Pole Induction Motor  
温度范围 Operating Temperature: –10°C~+65°C

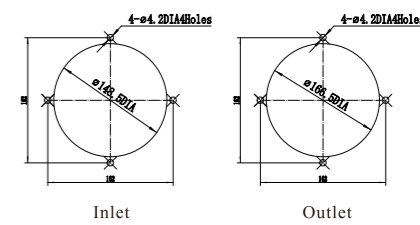

产品型号 Model	轴承型式 Bearing System	电压 Voltage VAC	频率 Freq. Hz	电流 Current A	功率 Power W	转速 Speed RPM	噪音 Noise dB(A)	风量 Air Flow CFM	相数 Phase	电容 Capacitor μF/VAC
G17251HA,S	Sleeve	100/125	50/60	0.50/0.45	37/36	2700/3100	45/50	190/235	1	—
G17251HA,S		200/240	50/60	0.22/0.21	34/33	2700/3100	45/50	190/235	1	—
G17251HA,S		380/420	50	0.11	34	2700	45	190	1	—
G17251HA,B	Ball	100/125	50/60	0.50/0.45	37/36	2700/3100	45/50	190/235	1	—
G17251HA,B		200/240	50/60	0.22/0.21	34/33	2700/3100	45/50	190/235	1	—
G17251HA,B		380/420	50	0.11	34	2700	45	190	1	—
G17251MA,S	Sleeve	100/125	50/60	0.41/0.39	32/30	2400/2300	41/40	170/160	1	—
G17251MA,S		200/240	50/60	0.19/0.18	30/28	2400/2300	41/40	170/160	1	—
G17251MA,S		380/420	50	0.09	30	2400	41	170	1	—
G17251MA,B	Ball	100/125	50/60	0.41/0.39	32/30	2400/2300	41/40	170/160	1	—
G17251MA,B		200/240	50/60	0.19/0.18	30/28	2400/2300	41/40	170/160	1	—
G17251MA,B		380/420	50	0.09	30	2400	41	170	1	—
G17251LA,S	Sleeve	100/125	50/60	0.35/0.35	26/25	1900/1500	32/30	125/105	1	—
G17251LA,S		200/240	50/60	0.16/0.16	26/25	1900/1500	32/30	125/105	1	—
G17251LA,S		380/420	50	0.07	26	1900	32	125	1	—
G17251LA,B	Ball	100/125	50/60	0.35/0.35	26/25	1900/1500	32/30	125/105	1	—
G17251LA,B		200/240	50/60	0.16/0.16	26/25	1900/1500	32/30	125/105	1	—
G17251LA,B		380/420	50	0.07	26	1900	32	125	1	—

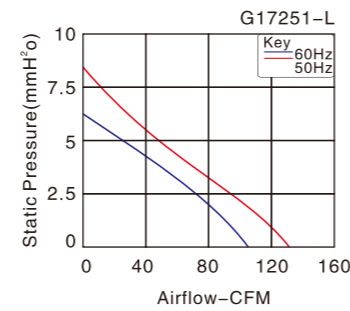
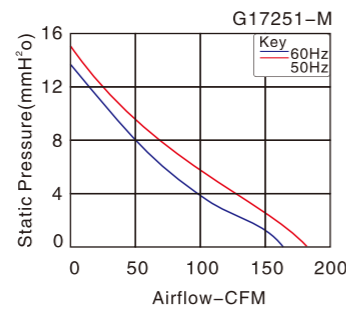
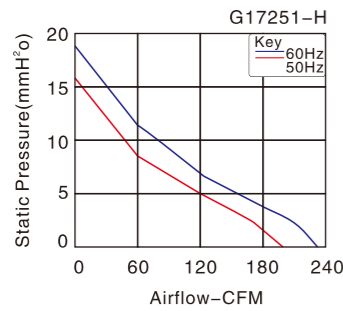

产品型号 Model	轴承型式 Bearing System	电压 Voltage VAC	频率 Freq. Hz	电流 Current A	功率 Power W	转速 Speed RPM	噪音 Noise dB(A)	风量 Air Flow CFM	相数 Phase	电容 Capacitor μF/VAC
G17251HA,S-7P	Sleeve	100/125	50/60	0.50/0.45	37/36	2600/3000	46/52	200/245	1	—
G17251HA,S-7P		200/240	50/60	0.22/0.21	34/33	2600/3000	46/52	200/245	1	—
G17251HA,S-7P		380/420	50	0.11	34	2600	46	200	1	—
G17251HA,B-7P	Ball	100/125	50/60	0.50/0.45	37/36	2600/3000	46/52	200/245	1	—
G17251HA,B-7P		200/240	50/60	0.22/0.21	34/33	2600/3000	46/52	200/245	1	—
G17251HA,B-7P		380/420	50	0.11	34	2600	46	200	1	—
G17251MA,S-7P	Sleeve	100/125	50/60	0.41/0.39	32/30	2400/2300	32/30	178/166	1	—
G17251MA,S-7P		200/240	50/60	0.19/0.18	30/28	2400/2300	43/42	178/166	1	—
G17251MA,S-7P		380/420	50	0.09	30	2400	43	178	1	—
G17251MA,B-7P	Ball	100/125	50/60	0.41/0.39	32/30	2400/2300	43/42	178/166	1	—
G17251MA,B-7P		200/240	50/60	0.19/0.18	30/28	2400/2300	43/42	178/166	1	—
G17251MA,B-7P		380/420	50	0.09	30	2400	43	178	1	—
G17251LA,S-7P	Sleeve	100/125	50/60	0.35/0.35	26/25	1900/1500	32/36	130/115	1	—
G17251LA,S-7P		200/240	50/60	0.16/0.16	26/25	1900/1500	32/36	130/115	1	—
G17251LA,S-7P		380/420	50	0.07	26	1900	35	130	1	—
G17251LA,B-7P	Ball	100/125	50/60	0.35/0.35	26/25	1900/1500	32/36	130/115	1	—
G17251LA,B-7P		200/240	50/60	0.16/0.16	26/25	1900/1500	32/36	130/115	1	—
G17251LA,B-7P		380/420	50	0.07	26	1900	35	130	1	—

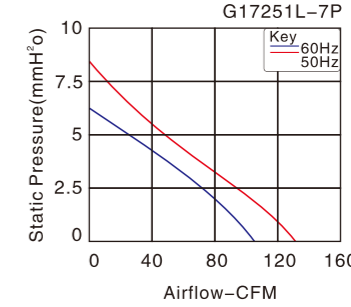
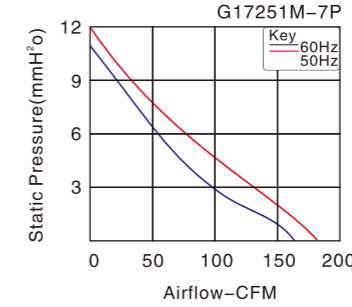
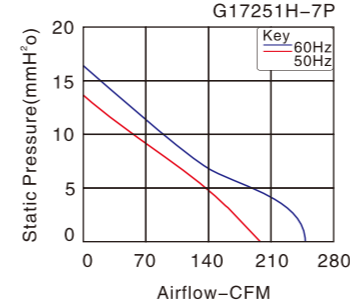

Fan Accessories

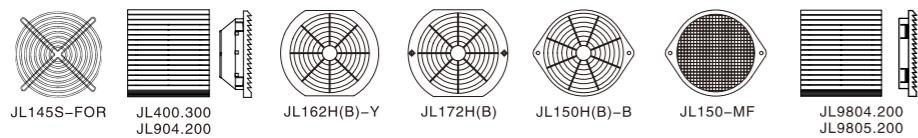

Fan Accessories

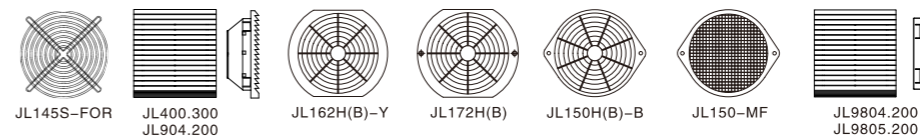

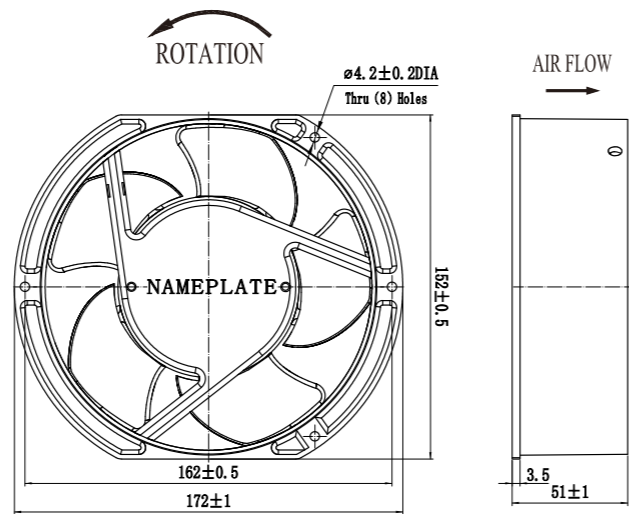

尺寸 Size: Ø172mm × 51mm  
风量 Airflow: 105–235CFM  
重量 Weight: 840g  
噪音 Noise: 30–50dB(A)  
风叶 Impeller Material: PBT UL94–V0 Reinforced Plastic  
外框 Frame: Aluminum Alloy  
端子 Terminals: 0.5mm  
引线 Lead Wire: AWG#22 UL 1569(Optional)  
马达 Motor: Shaded Pole Induction Motor  
温度范围 Operating Temperature: –10°C~+65°C

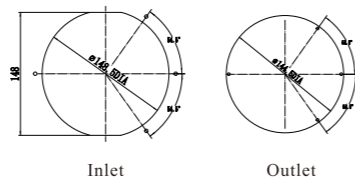

产品型号 Model	轴承型式 Bearing System	电压 Voltage VAC	频率 Freq. Hz	电流 Current A	功率 Power W	转速 Speed RPM	噪音 Noise dB(A)	风量 Air Flow CFM	相数 Phase	电容 Capacitor μF/VAC
G17050HA,S-D	Sleeve	100/125	50/60	0.50/0.45	37/36	2700/3100	45/50	190/235	1	—
G17050HA,S-D		200/240	50/60	0.22/0.21	34/33	2700/3100	45/50	190/235	1	—
G17050HA,S-D		380/420	50	0.11	34	2700	45	190	1	—
G17050HA,B-D	Ball	100/125	50/60	0.50/0.45	37/36	2700/3100	45/50	190/235	1	—
G17050HA,B-D		200/240	50/60	0.22/0.21	34/33	2700/3100	45/50	190/235	1	—
G17050HA,B-D		380/420	50	0.11	34	2700	45	190	1	—
G17050MA,S-D	Sleeve	100/125	50/60	0.41/0.39	32/30	2400/2300	41/40	170/160	1	—
G17050MA,S-D		200/240	50/60	0.19/0.18	30/28	2400/2300	41/40	170/160	1	—
G17050MA,S-D		380/420	50	0.09	30	2400	41	170	1	—
G17050MA,B-D	Ball	100/125	50/60	0.41/0.39	32/30	2400/2300	41/40	170/160	1	—
G17050MA,B-D		200/240	50/60	0.19/0.18	30/28	2400/2300	41/40	170/160	1	—
G17050MA,B-D		380/420	50	0.09	30	2400	41	170	1	—
G17050LA,S-D	Sleeve	100/125	50/60	0.35/0.35	26/25	1900/1500	32/30	125/105	1	—
G17050LA,S-D		200/240	50/60	0.16/0.16	26/25	1900/1500	32/30	125/105	1	—
G17050LA,S-D		380/420	50	0.07	26	1900	32	125	1	—
G17050LA,B-D	Ball	100/125	50/60	0.35/0.35	26/25	1900/1500	32/30	125/105	1	—
G17050LA,B-D		200/240	50/60	0.16/0.16	26/25	1900/1500	32/30	125/105	1	—
G17050LA,B-D		380/420	50	0.07	26	1900	32	125	1	—

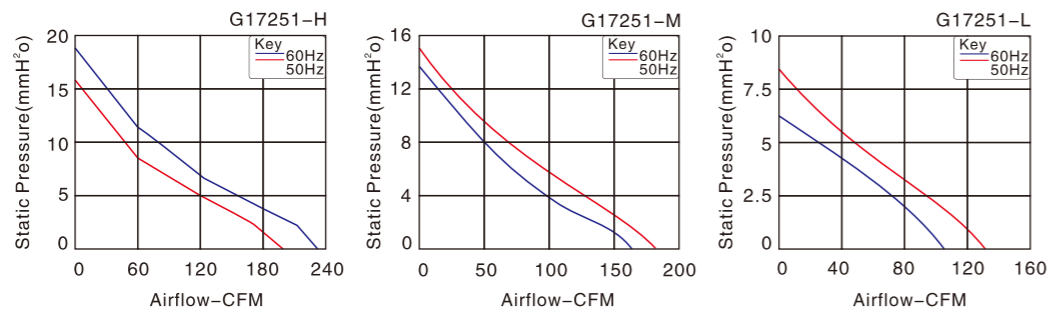

Fan Accessories

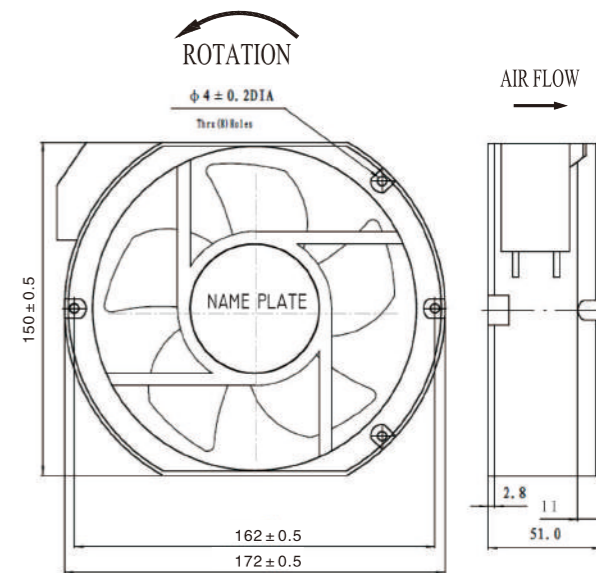
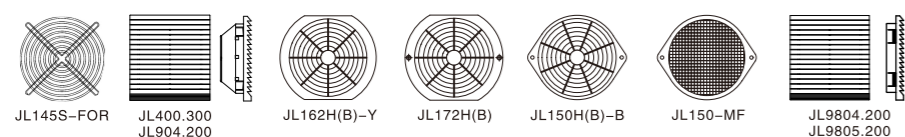

尺寸 Size: 172mm × 150mm × 51mm  
风量 Airflow: 215–225CFM  
重量 Weight: 880g  
噪音 Noise: 51–58dB(A)  
风叶 Impeller Material: PBT UL94–V0 Reinforced Plastic  
外框 Frame: Aluminum Alloy  
端子 Terminals: 0.5mm  
引线 Lead Wire: AWG#22 UL 1569(Optional)  
马达 Motor: Capacitor-Run Induction Motor  
温度范围 Operating Temperature: –10°C~+65°C

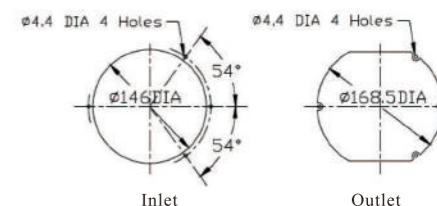

产品型号 Model	轴承型式 Bearing System	电压 Voltage VAC	频率 Freq. Hz	电流 Current A	功率 Power W	转速 Speed RPM	噪音 Noise dB(A)	风量 Air Flow CFM	相数 Phase	电容 Capacitor μF/VAC
G17050HA,B-C	Ball	100/125	50/60	0.38/0.32	35/34	2850/3350	51/58	215/225	1	3.3/250
G17050HA,B-C	Ball	200/240	50/60	0.11/0.11	25/27	2850/3350	51/58	215/225	1	0.75/500

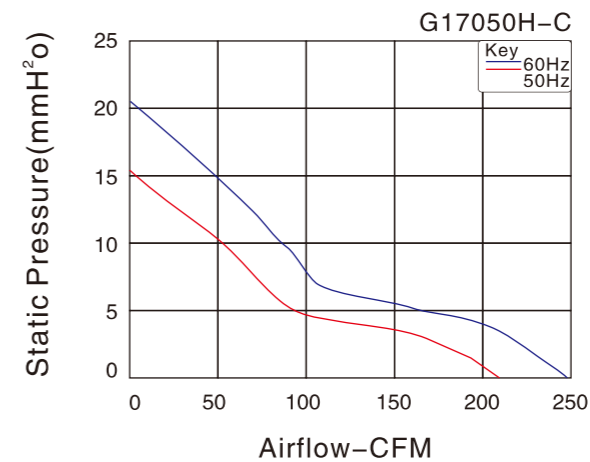

Fan Accessories

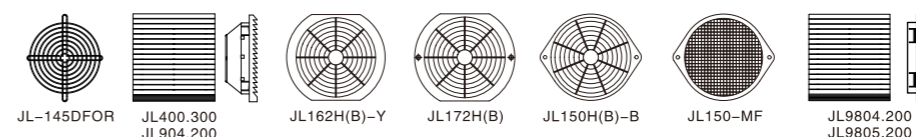

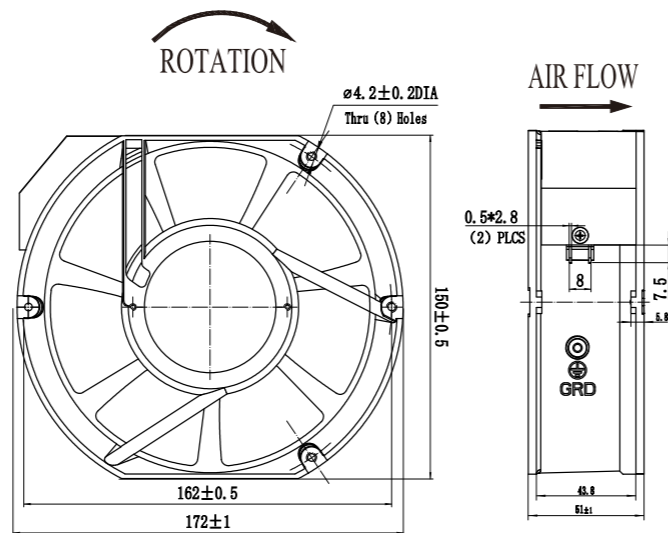

尺寸 Size: 172mm × 150mm × 51mm  
风量 Airflow: 210~293CFM  
重量 Weight: 960g  
噪音 Noise: 53~61dB(A)  
风叶 Impeller Material: PBT UL94-V0 Reinforced Plastic  
外框 Frame: Aluminum Alloy  
端子 Terminals: 0.5mm  
引线 Lead Wire: AWG#22 UL 1569(Optional)  
马达 Motor: Capacitor-Run Induction Motor  
温度范围 Operating Temperature: -10°C~+65°C

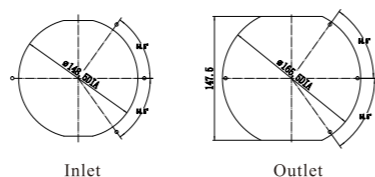

产品型号 Model	轴承型式 Bearing System	电压 Voltage VAC	频率 Freq. Hz	电流 Current A	功率 Power W	转速 Speed RPM	噪音 Noise dB(A)	风量 Air Flow CFM	相数 Phase	电容 Capacitor μF/VAC
G17050HA,B-7P-C	Ball	100/125	50/60	0.38/0.35	37/38	2850/3300	56/61	250/293	1	3.3/250
G17050HA,B-7P-C		200/240	50/60	0.24/0.23	50/49	2850/3300	53/55	250/293	1	1.5/500
G17050MA,B-7P-C	Bal	100/125	50/60	0.35/0.4	46/50	2500/3300	56/61	210/245	1	3.3/250
G17050MA,B-7P-C		200/240	50/60	0.26/0.29	39/40	2500/2800	53/55	210/245	1	1/500

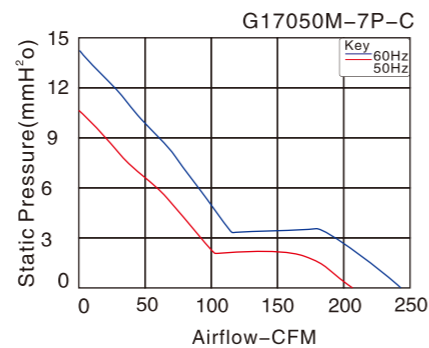
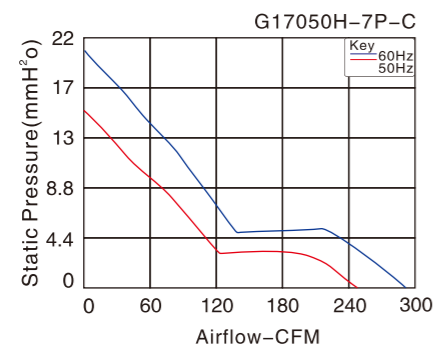

Fan Accessories

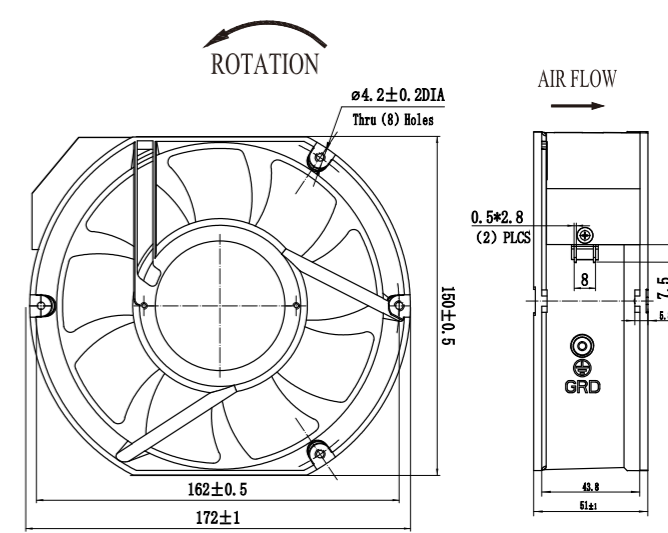
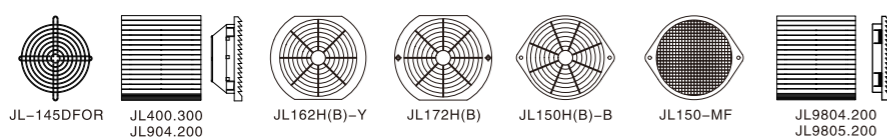

尺寸 Size: 172mm × 150mm × 51mm  
风量 Airflow: 257~300CFM  
重量 Weight: 920g  
噪音 Noise: 46~56dB(A)  
风叶 Impeller Material: PBT UL94-V0 Reinforced Plastic  
外框 Frame: Aluminum Alloy  
端子 Terminals: 0.5mm  
引线 Lead Wire: AWG#22 UL 1569(Optional)  
马达 Motor: Capacitor-Run Induction Motor  
温度范围 Operating Temperature: -10°C~+65°C

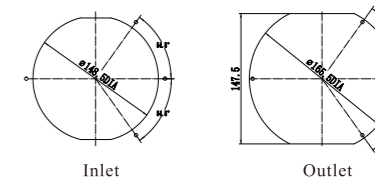

产品型号 Model	轴承型式 Bearing System	电压 Voltage VAC	频率 Freq. Hz	电流 Current A	功率 Power W	转速 Speed RPM	噪音 Noise dB(A)	风量 Air Flow CFM	相数 Phase	电容 Capacitor μF/VAC
G17050HA,B-9P-C	Ball	100/125	50/60	0.46/0.47	53	2850/3350	46/56	257/300	1	3.3/250
G17050HA,B-9P-C	Ball	200/240	50/60	0.25	53	2850/3350	46/56	257/300	1	1.5/500
G17050HA,B-9P-C	Ball	380/420	50/60	0.15	53	2850/3350	46/56	257/300	1	0.75/500

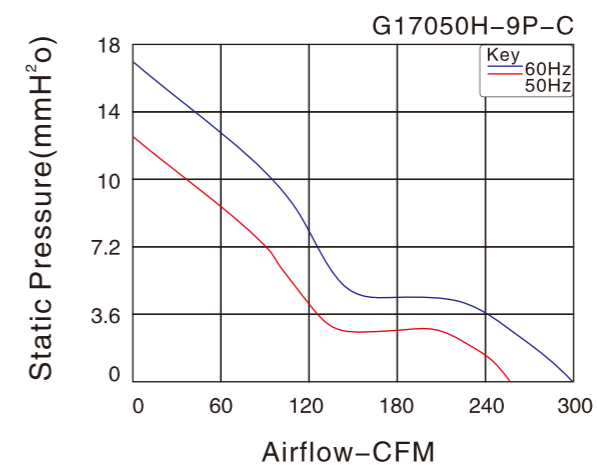

Fan Accessories

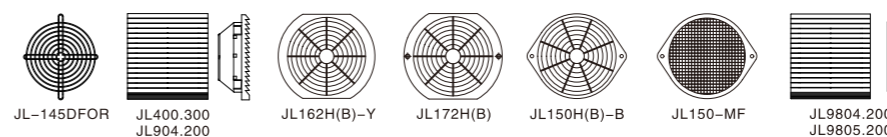

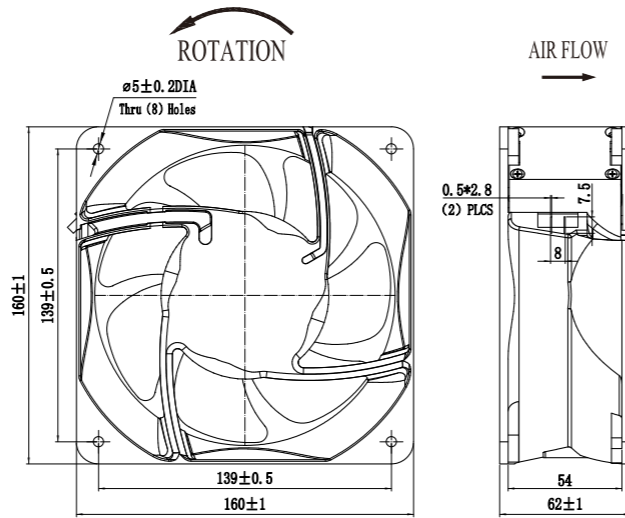

尺寸 Size: 160mm × 160mm × 62mm  
风量 Airflow: 220–275CFM  
重量 Weight: 1200g  
噪音 Noise: 50–59dB(A)  
风叶 Impeller Material: PBT UL94–V0 Reinforced Plastic  
外框 Frame: Aluminum Alloy  
端子 Terminals: 0.5mm  
引线 Lead Wire: AWG#22 UL 1569(Optional)  
马达 Motor: Capacitor–Run Induction Motor  
温度范围 Operating Temperature: –10°C~+65°C

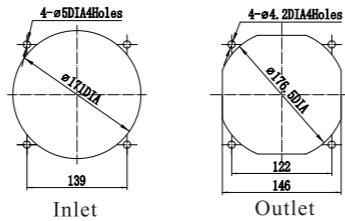

产品型号 Model	轴承型式 Bearing System	电压 Voltage VAC	频率 Freq. Hz	电流 Current A	功率 Power W	转速 Speed RPM	噪音 Noise dB(A)	风量 Air Flow CFM	相数 Phase	电容 Capacitor μF/VAC
G16062HA,B–C–7P	Ball	100/125	50/60	0.38/0.37	37/39	2750/3050	54/59	240/275	1	3.3/250
G16062HA,B–C–7P		200/240	50/60	0.15/0.17	30/36	2750/3050	54/59	240/275	1	1/500
G16062HA,B–C–7P	Ball	380/420	50/60	0.08/0.09	30/35	2300/2600	50/54	220/225	3	—
G16062HA,B–C–7P		380/420	50/60	0.1	30/35	2300/2600	50/54	220/255	1	0.33/500
G16062MA,B–C–7P	Ball	100/125	50/60	0.35	35	2300/2600	50/54	220/225	1	3.3/250
G16062MA,B–C–7P		200/240	50/60	0.18	35	2300/2600	50/54	220/255	1	1/500

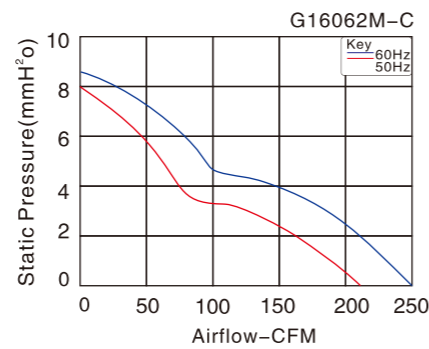
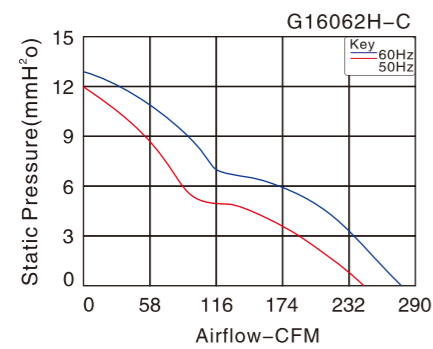

Fan Accessories

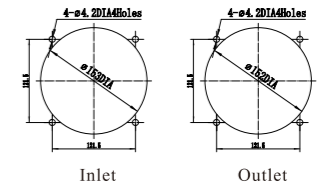
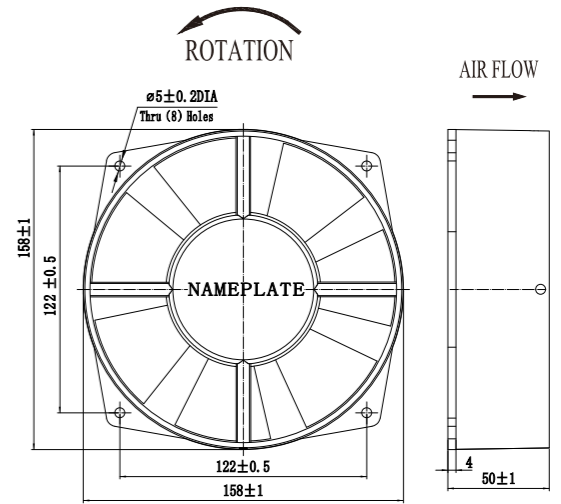

尺寸 Size: 158mm × 158mm × 50mm  
风量 Airflow: 240–270CFM  
重量 Weight: 870g  
噪音 Noise: 58–60dB(A)  
风叶 Impeller Material: PBT UL94–V0 Reinforced Plastic  
外框 Frame: Aluminum Alloy  
端子 Terminals: 0.5mm  
引线 Lead Wire: AWG#22 UL 1332(Optional)  
马达 Motor: Capacitor–Run Induction Motor  
温度范围 Operating Temperature: –10°C~+65°C

产品型号 Model	轴承型式 Bearing System	电压 Voltage VAC	频率 Freq. Hz	电流 Current A	功率 Power W	转速 Speed RPM	噪音 Noise dB(A)	风量 Air Flow CFM	相数 Phase	电容 Capacitor μF/VAC
150FZY8–D	Ball	200/240	50/60	0.2/0.23	43/50	2750/3100	58/60	240/270	1	1/500
150FZY9–D	Ball	380/420	50/60	0.11/0.14	35/49	2750/3100	58/60	240/270	1	0.33/500

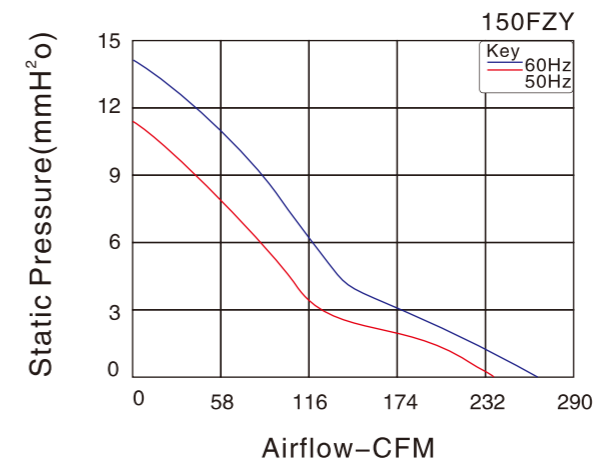

Fan Accessories

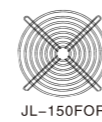

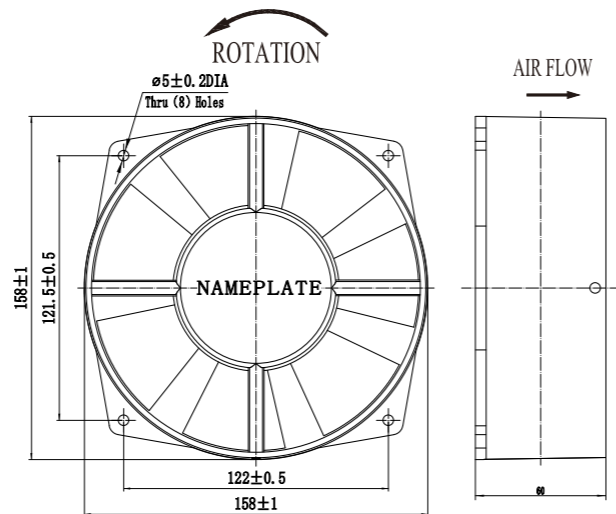

尺寸 Size: 160mm × 160mm × 60mm  
风量 Airflow: 194–223CFM  
重量 Weight: 1250g  
噪音 Noise: 65–68dB(A)  
风叶 Impeller Material: Polypropylene  
外框 Frame: Aluminum Alloy  
端子 Terminals: 0.5mm  
引线 Lead Wire: AWG#22 UL 1332(Optional)  
马达 Motor: Capacitor-Run Induction Motor  
温度范围 Operating Temperature: -10°C~+65°C

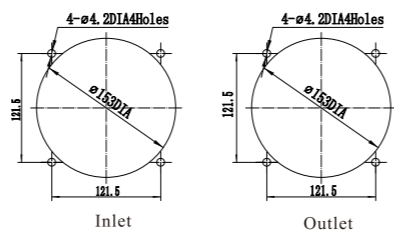

产品型号 Model	轴承型式 Bearing System	电压 Voltage VAC	频率 Freq. Hz	电流 Current A	功率 Power W	转速 Speed RPM	噪音 Noise dB(A)	风量 Air Flow CFM	相数 Phase	电容 Capacitor μF/VAC
G16060HA <sub>1</sub> -C	Ball	100/125	50/60	0.32	30	2750/3150	65/68	194/223	1	3/500
G16060HA <sub>2</sub> -C	Ball	200/240	50/60	0.13/0.1	25/24	2750/3150	65/68	194/223	1	1/500
G16060HA <sub>3</sub>	Ball	380/420	50/60	0.10	25	2750/3150	65/68	194/223	3	—
G16060HA <sub>4</sub> -C	Ball	380/420	50/60	0.10	23/25	2750/3150	65/68	194/223	1	0.47/500

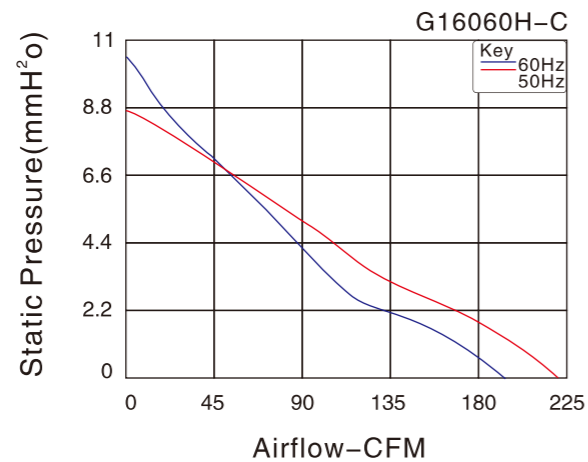

Fan Accessories

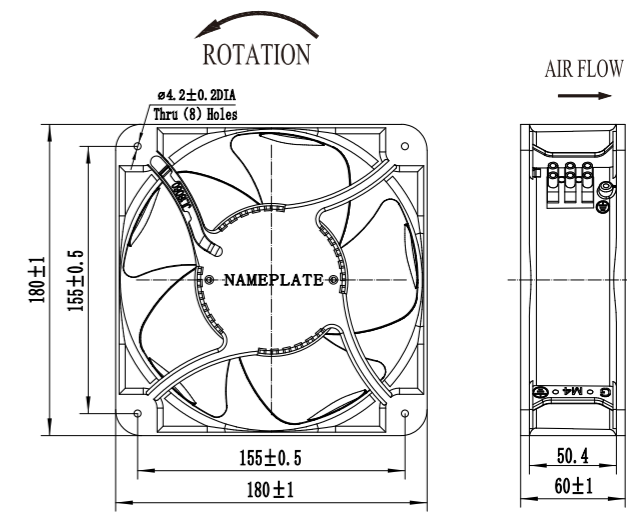

尺寸 Size: 180mm × 180mm × 60mm  
风量 Airflow: 289–312CFM  
重量 Weight: 1460g  
噪音 Noise: 61–65dB(A)  
风叶 Impeller Material: PBT UL94-V0 Reinforced Plastic  
外框 Frame: Aluminum Alloy  
端子 Terminals: Terminal block  
引线 Lead Wire: AWG#UL1332 22#(Optional)  
马达 Motor: Shaded Pole Induction Motor  
温度范围 Operating Temperature: -10°C~+65°C

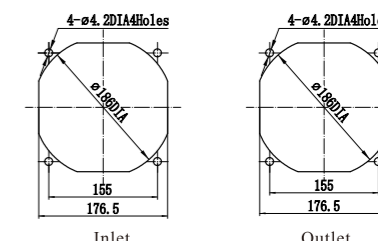

产品型号 Model	轴承型式 Bearing System	电压 Voltage VAC	频率 Freq. Hz	电流 Current A	功率 Power W	转速 Speed RPM	噪音 Noise dB(A)	风量 Air Flow CFM	相数 Phase	电容 Capacitor μF/VAC
G18060HA <sub>2</sub> BL	Ball	200/240	50/60	0.32/0.3	39/38	2800/3050	61/65	289/312	1	—

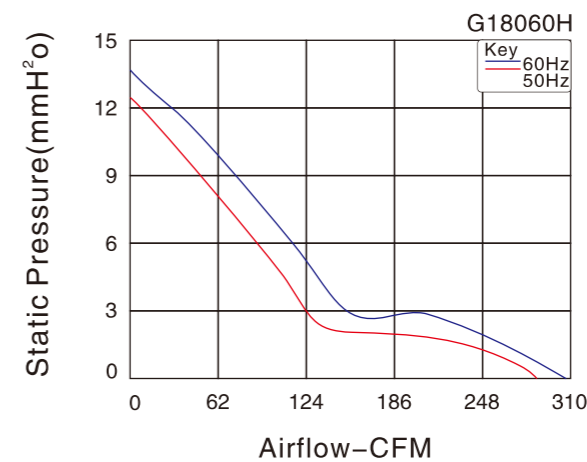

Fan Accessories



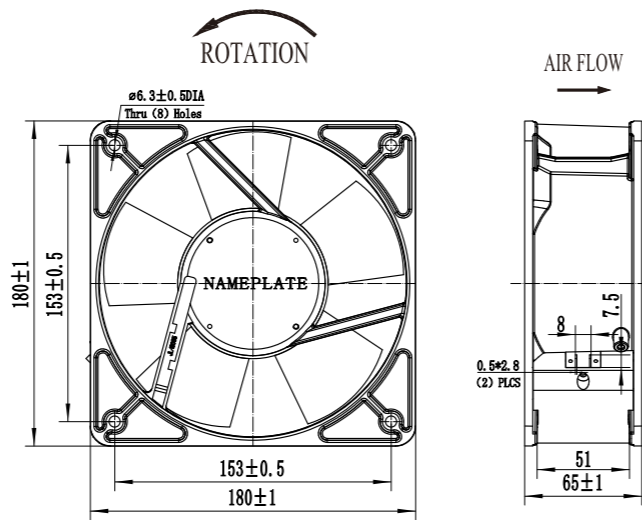

尺寸 Size: 180mm × 180mm × 65mm  
风量 Airflow: 355-385CFM  
重量 Weight: 1190g  
噪音 Noise: 60-62dB(A)  
风叶 Impeller Material: PBT UL94-V0 Reinforced Plastic  
外框 Frame: Aluminum Alloy  
端子 Terminals: 0.5mm  
引线 Lead Wire: AWG#24 UL 1332(Optional)  
马达 Motor: Capacitor-Run Induction Motor  
温度范围 Operating Temperature: -10°C~+65°C

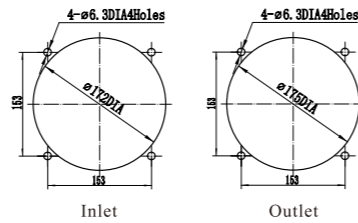

产品型号 Model	轴承型式 Bearing System	电压 Voltage VAC	频率 Freq. Hz	电流 Current A	功率 Power W	转速 Speed RPM	噪音 Noise dB(A)	风量 Air Flow CFM	相数 Phase	电容 Capacitor μF/VAC
G18065HA,B-C	Ball	100/125	50/60	0.42/0.55	46/59	2700/3000	60/62	355/385	1	3.3/250
G18065HA <sub>2</sub> B-C	Ball	200/240	50/60	0.19/0.24	40/50	2700/3000	60/62	355/385	1	1.5/500
G18065HA <sub>3</sub> B-C	Ball	380/420	50	0.15	40/50	2700	60	355	3	—

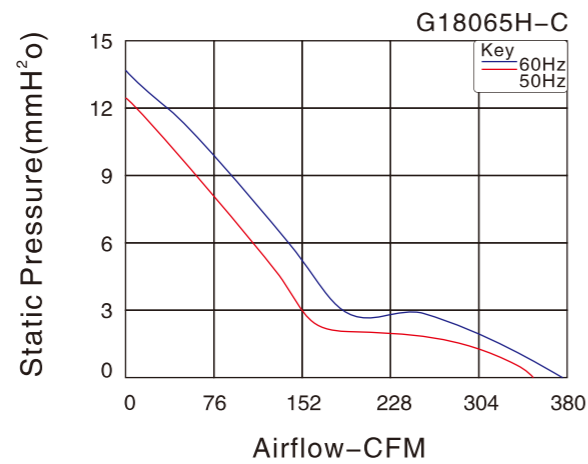

Fan Accessories



JL180FOR

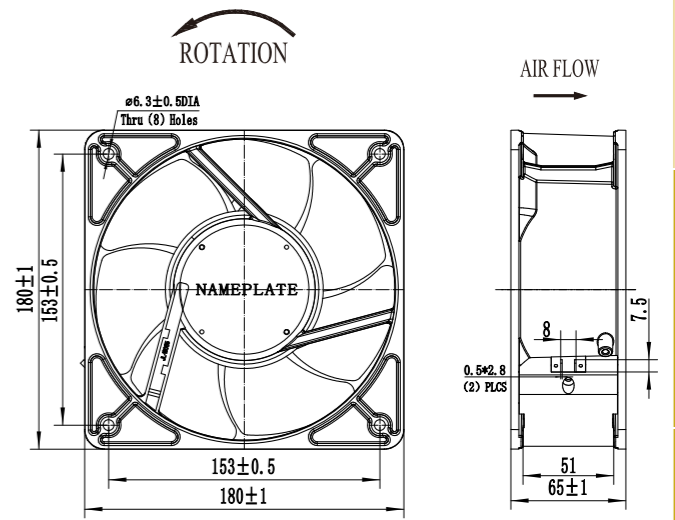

尺寸 Size: 180mm × 180mm × 65mm  
风量 Airflow: 385CFM  
重量 Weight: 1200g  
噪音 Noise: 60dB(A)  
风叶 Impeller Material: PBT UL94-V0 Reinforced Plastic  
外框 Frame: Aluminum Alloy  
端子 Terminals: Terminal block  
引线 Lead Wire: AWG#UL1332 22#(Optional)  
马达 Motor: Capacitor-Run Induction Motor  
温度范围 Operating Temperature: -10°C~+65°C

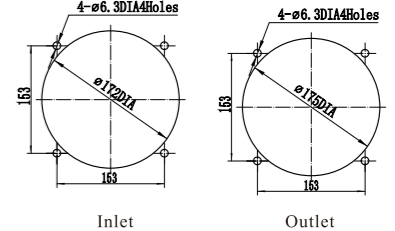

产品型号 Model	轴承型式 Bearing System	电压 Voltage VAC	频率 Freq. Hz	电流 Current A	功率 Power W	转速 Speed RPM	噪音 Noise dB(A)	风量 Air Flow CFM	相数 Phase	电容 Capacitor μF/VAC
G18065HA <sub>2</sub> BL	Ball	200/240	50	0.24	52	2600	60	385	1	1.5/500

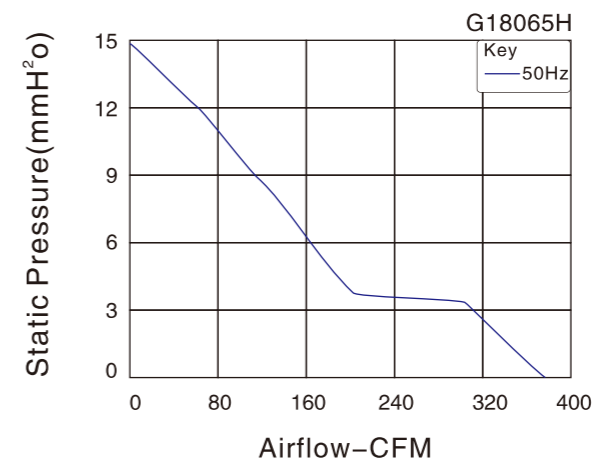

Fan Accessories



JL180FOR

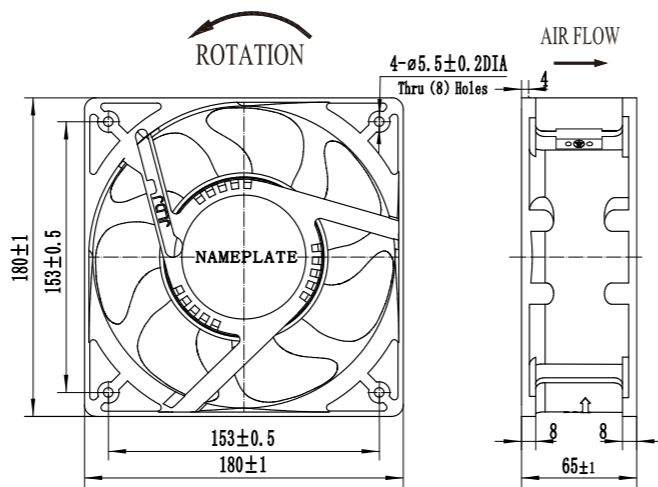

尺寸 Size: 180mm × 180mm × 65mm  
风量 Airflow: 450–500CFM  
重量 Weight: 1188g  
噪音 Noise: 61–65dB(A)  
风叶 Impeller Material: PBT UL94–V0 Reinforced Plastic  
外框 Frame: Aluminum Alloy  
端子 Terminals: 0.5mm  
引线 Lead Wire: AWG#22 UL 1015(Optional)  
马达 Motor: Capacitor–Run Induction Motor  
温度范围 Operating Temperature: –10°C~+65°C

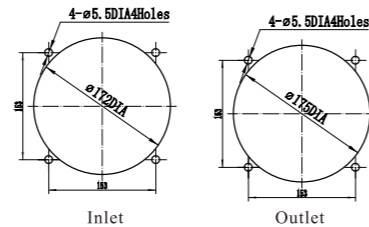

产品型号 Model	轴承型式 Bearing System	电压 Voltage VAC	频率 Freq. Hz	电流 Current A	功率 Power W	转速 Speed RPM	噪音 Noise dB(A)	风量 Air Flow CFM	相数 Phase	电容 Capacitor μF/VAC
G18065HA,B–C–7P	Ball	100/125	50/60	0.5/0.6	60/85	2800/3200	61/65	450/500	1	3.3/250
G18065HA <sub>2</sub> ,B–C–7P	Ball	200/240	50/60	0.25/0.37	56/75	2800/3200	61/65	450/500	1	1.8/500

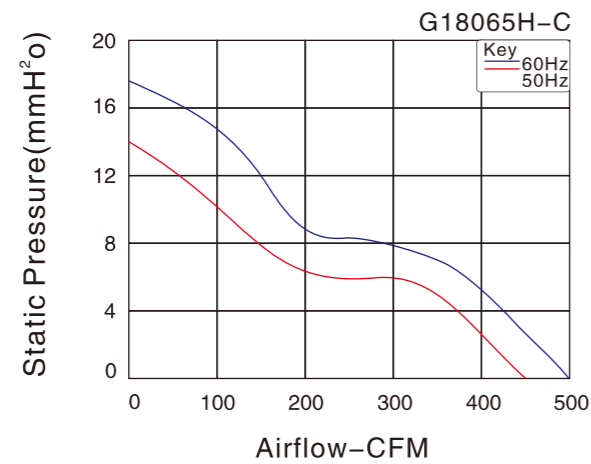

Fan Accessories

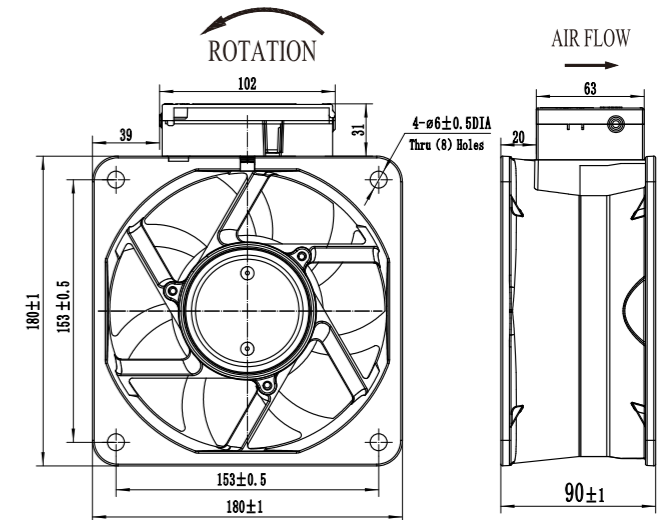

尺寸 Size: 180mm × 180mm × 89mm  
风量 Airflow: 444–519CFM  
重量 Weight: 2150g  
噪音 Noise: 56–60dB(A)  
风叶 Impeller Material: PBT UL94–V0 Reinforced Plastic  
外框 Frame: Aluminum Alloy  
端子 Terminals: 0.5mm  
引线 Lead Wire: AWG#22 UL 1015(Optional)  
马达 Motor: Capacitor–Run Induction Motor  
温度范围 Operating Temperature: –10°C~+65°C

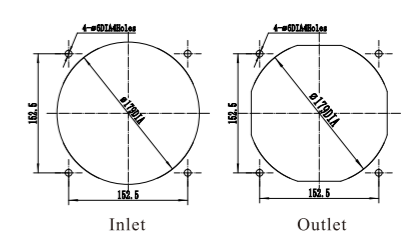

产品型号 Model	轴承型式 Bearing System	电压 Voltage VAC	频率 Freq. Hz	电流 Current A	功率 Power W	转速 Speed RPM	噪音 Noise dB(A)	风量 Air Flow CFM	相数 Phase	电容 Capacitor μF/VAC
G18089HA,B	Ball	100/125	50/60	0.75/0.9	80/100	2850/3300	56/60	444/519	1	6/500
G18089HA <sub>2</sub> ,B	Ball	200/240	50/60	0.36/0.43	72/94	2850/3300	56/60	444/519	1	1.8/500
G18089HA <sub>2</sub> ,BL	Ball	380/420	50	0.19/0.25	68/88	2850/3300	56/60	444/519	1	1.5/500
G18089HA <sub>2</sub> ,BL	Ball	220三相	50/60	0.36/0.43	76/96	2850/3300	56/60	444/519	1	—

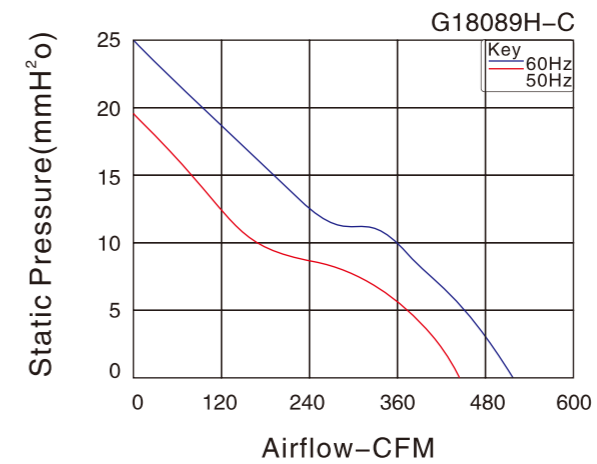

Fan Accessories



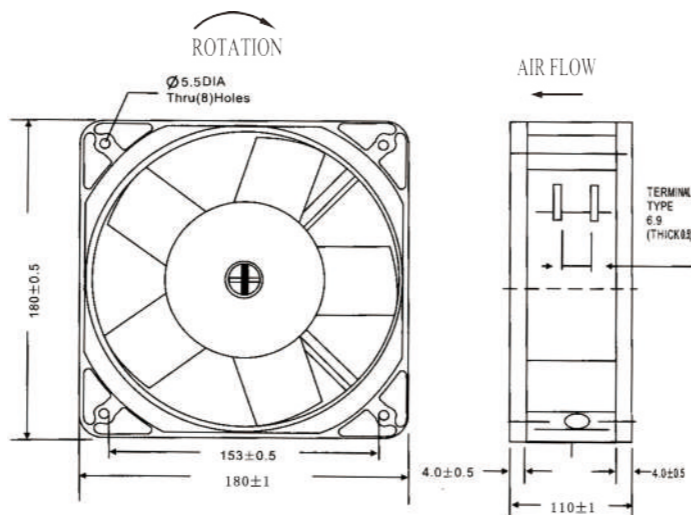

尺寸 Size: 180mm × 180mm × 110mm  
风量 Airflow: 430-500CFM  
重量 Weight: 2480g  
噪音 Noise: 65-72dB(A)  
风叶 Impeller Material: PBT UL94-V0 Reinforced Plastic  
外框 Frame: Aluminum Alloy  
端子 Terminals: 0.5mm  
引线 Lead Wire: AWG#22 UL 1015(Optional)  
马达 Motor: Capacitor-Run Induction Motor  
温度范围 Operating Temperature: -10°C~+65°C

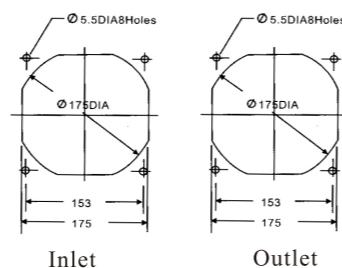

产品型号 Model	轴承型式 Bearing System	电压 Voltage VAC	频率 Freq. Hz	电流 Current A	功率 Power W	转速 Speed RPM	噪音 Noise dB(A)	风量 Air Flow CFM	相数 Phase	电容 Capacitor μF/VAC
G180110HA,B-C	Ball	100/125	50/60	0.82	80	2600/3000	68/72	430/500	1	4/250
G180110HA <sub>2</sub> B-C	Ball	200/240	50/60	0.35/0.38	60/75	2850/3250	65/69	430/500	1	2/500

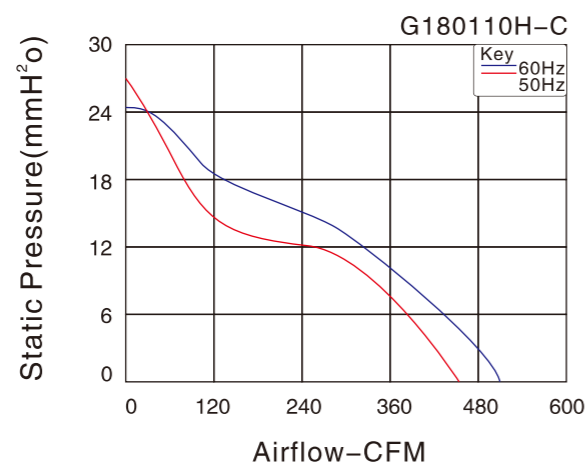

Fan Accessories

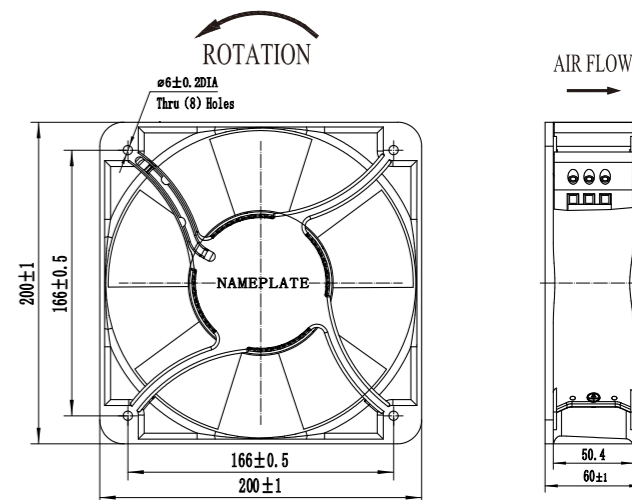

尺寸 Size: 200mm × 200mm × 60mm  
风量 Airflow: 240-400CFM  
重量 Weight: 1700g  
噪音 Noise: 54-69dB(A)  
风叶 Impeller Material: PBT UL94-V0 Reinforced Plastic  
外框 Frame: Aluminum Alloy  
端子 Terminals: 0.5mm  
引线 Lead Wire: AWG#22 UL 1332(Optional)  
马达 Motor: Capacitor-Run Induction Motor  
温度范围 Operating Temperature: -10°C~+65°C

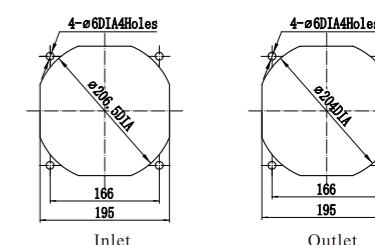

产品型号 Model	轴承型式 Bearing System	电压 Voltage VAC	频率 Freq. Hz	电流 Current A	功率 Power W	转速 Speed RPM	噪音 Noise dB(A)	风量 Air Flow CFM	相数 Phase	电容 Capacitor μF/VAC
G20060HA,B	Ball	100/125	50/60	0.83/0.95	60/70	2550/1950	61/54	382/240	1	/
G20060HA <sub>2</sub> B	Ball	200/240	50/60	0.48/0.5	68/75	2550/2250	66/62	382/291	1	/
G20060HA <sub>3</sub> B-C	Ball	380/420	50/60	0.16/0.18	25/40	2650/2800	68/69	400/390	1	1/500

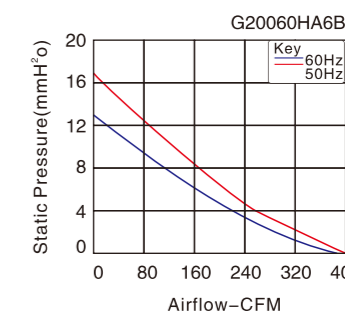
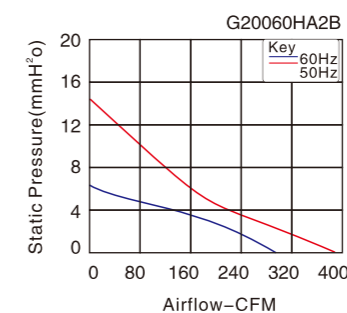
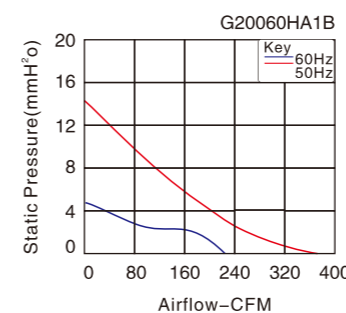

Fan Accessories

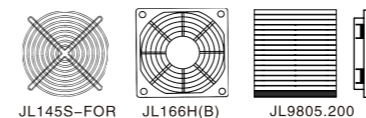

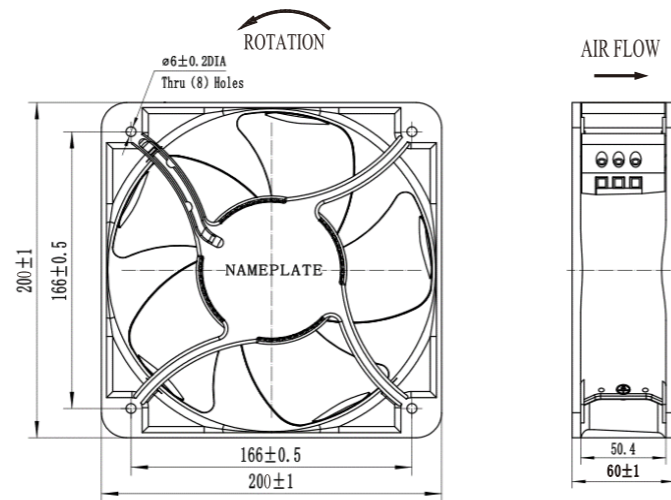

尺寸 Size: 200mm × 200mm × 60mm  
风量 Airflow: 357–386CFM  
重量 Weight: 1600g  
噪音 Noise: 63–67dB(A)  
风叶 Impeller Material: PBT UL94–V0 Reinforced Plastic  
外框 Frame: Aluminum Alloy  
端子 Terminals: Terminal block  
引线 Lead Wire: AWG#UL1332 22#(Optional)  
马达 Motor: Shaded Pole Induction Motor  
温度范围 Operating Temperature: –10°C~+65°C

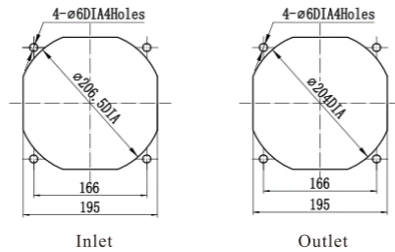

产品型号 Model	轴承型式 Bearing System	电压 Voltage VAC	频率 Freq. Hz	电流 Current A	功率 Power W	转速 Speed RPM	噪音 Noise dB(A)	风量 Air Flow CFM	相数 Phase	电容 Capacitor μF/VAC
G20060HA <sub>2</sub> BL	Ball	200/240	50/60	0.4/0.37	56/53	2800/3150	63/67	357/386	1	/

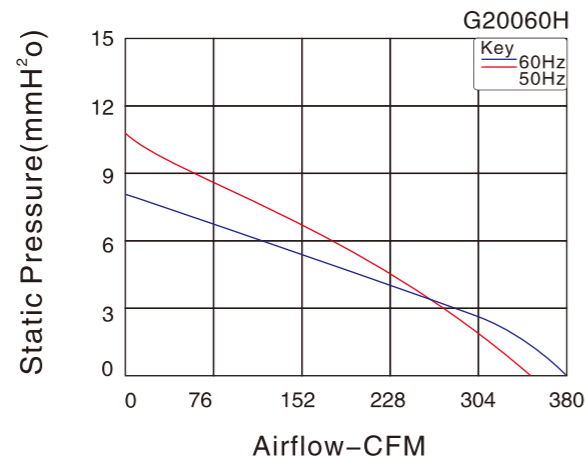

Fan Accessories

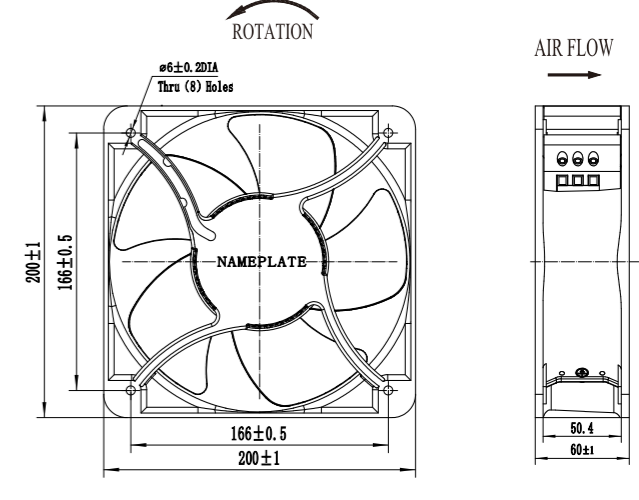
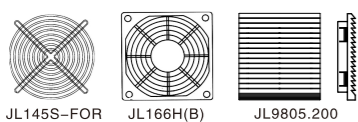

尺寸 Size: 200mm × 200mm × 60mm  
风量 Airflow: 350–530CFM  
重量 Weight: 1480g  
噪音 Noise: 54–65dB(A)  
风叶 Impeller Material: PBT UL94–V0 Reinforced Plastic  
外框 Frame: Aluminum Alloy  
端子 Terminals: 0.5mm  
引线 Lead Wire: AWG#24 UL 1332(Optional)  
马达 Motor: Capacitor-Run Induction Motor  
温度范围 Operating Temperature: –10°C~+65°C

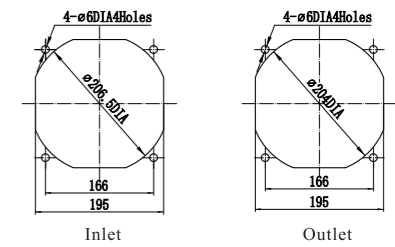

产品型号 Model	轴承型式 Bearing System	电压 Voltage VAC	频率 Freq. Hz	电流 Current A	功率 Power W	转速 Speed RPM	噪音 Noise dB(A)	风量 Air Flow CFM	相数 Phase	电容 Capacitor μF/VAC
G20060HA <sub>2</sub> B-W-C	Ball	100/125	50/60	0.5/0.6	51/63	2600/2450	58/54	485/430	1	3.3/250
G20060HA <sub>2</sub> B-W-C	Ball	200/240	50/60	0.28/0.34	54/72	2600/2450	60/65	485/430	1	1.5/500
G20060HA <sub>2</sub> B-W	Ball	380/420	50/60	0.15/0.17	52/62	2600/2450	60/65	485/430	3	/
G20060HA <sub>2</sub> B-W-C	Ball	380/420	50/60	0.2	60	2600/2450	60/65	460/530	1	1/500
G20060MA <sub>2</sub> B-W-C	Ball	100/125	50/60	0.6	60	2100/2500	60/65	350/400	3	3.3/250
G20060MA <sub>2</sub> B-W-C	Ball	200/240	50/60	0.25	42	2100/2500	60/65	350/400	1	1/500

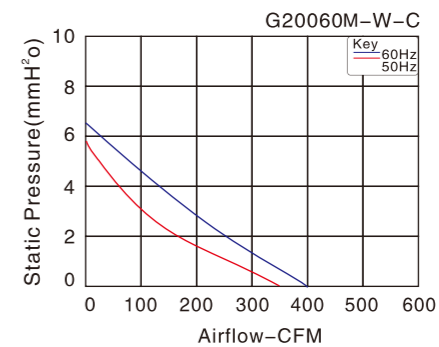
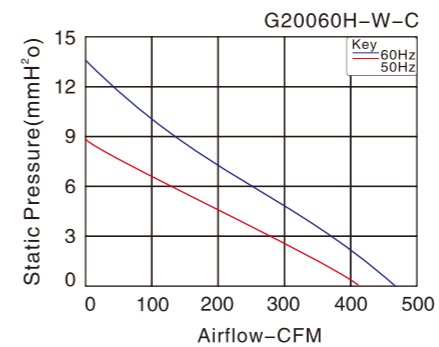

Fan Accessories

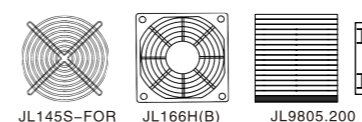

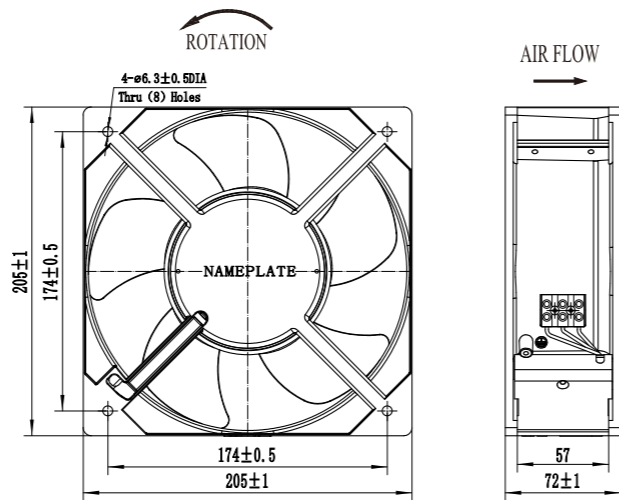

尺寸 Size: 205mm × 205mm × 72mm  
风量 Airflow: 610-725CFM  
重量 Weight: 2100g  
噪音 Noise: 61-71dB(A)  
风叶 Impeller Material: PBT UL94-V0 Reinforced Plastic  
外框 Frame: Aluminum Alloy  
端子 Terminals: 0.5mm  
引线 Lead Wire: AWG#24 UL 1332(Optional)  
马达 Motor: Capacitor-Run Induction Motor  
温度范围 Operating Temperature: -10°C~+65°C

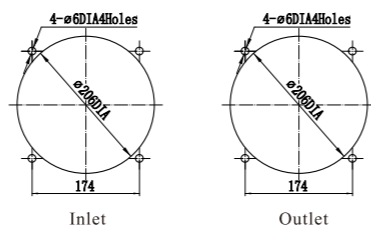

产品型号 Model	轴承型式 Bearing System	电压 Voltage VAC	频率 Freq. Hz	电流 Current A	功率 Power W	转速 Speed RPM	噪音 Noise dB(A)	风量 Air Flow CFM	相数 Phase	电容 Capacitor µF/VAC
G20572HA <sub>1</sub> B-C	Ball	100/125	50/60	0.62/0.88	70/100	2800/3200	67/71	610/725	1	8/250
G20572HA <sub>2</sub> B-C	Ball	200/240	50/60	0.35/0.5	70/100	2800/3200	67/71	610/725	1	3/500
G20572HA <sub>3</sub> B-C	Ball	380/420	50/60	0.18/0.26	68/98	2800/3200	67/71	610/725	1	—
G20572HA <sub>4</sub> B-C	Ball	380/420	50/60	0.18/0.26	68/98	2800/3200	67/71	610/725	1	1/500

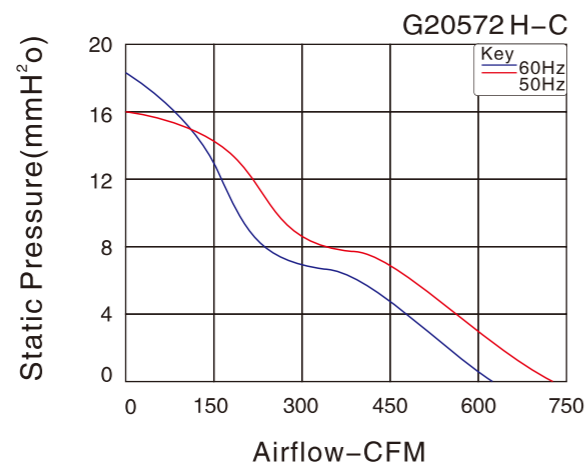

Fan Accessories

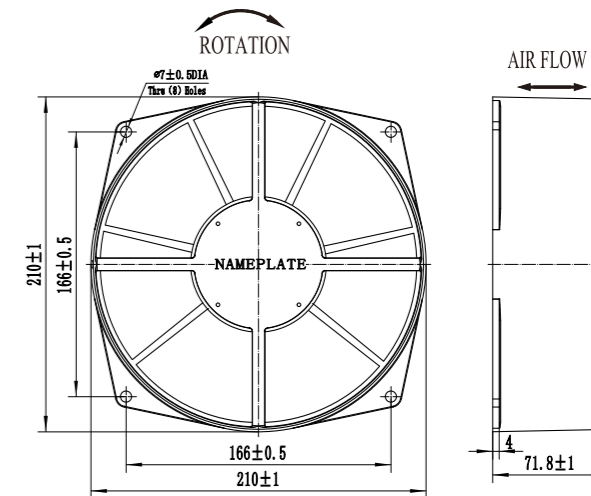
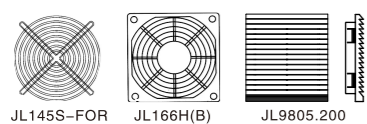

尺寸 Size: 210mm × 210mm × 70mm  
风量 Airflow: 419-468CFM  
重量 Weight: 1700g  
噪音 Noise: 70-75dB(A)  
风叶 Impeller Material: Polypropylene  
外框 Frame: Aluminum Alloy  
端子 Terminals: 0.5mm  
引线 Lead Wire: AWG#24 UL 1332(Optional)  
马达 Motor: Capacitor-Run Induction Motor  
温度范围 Operating Temperature: -10°C~+65°C

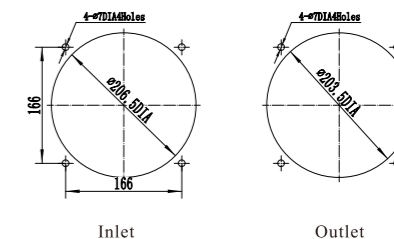

产品型号 Model	轴承型式 Bearing System	电压 Voltage VAC	频率 Freq. Hz	电流 Current A	功率 Power W	转速 Speed RPM	噪音 Noise dB(A)	风量 Air Flow CFM	相数 Phase	电容 Capacitor µF/VAC
G21070HA <sub>1</sub> -C	Ball	100/125	50/60	0.35/0.43	45/52	2550/2950	70/75	419/468	1	3.3/250
G21070HA <sub>2</sub> -C	Ball	200/240	50/60	0.2/0.22	45/52	2550/2950	70/75	419/468	1	1/500
G21070HA <sub>3</sub>	Ball	380/420	50/60	0.13/0.15	45/58	2550/2950	70/75	419/468	3	—
G21070HA <sub>4</sub> -C	Ball	380/420	50/60	0.11/0.13	45/58	2550/2950	70/75	419/468	1	1/500

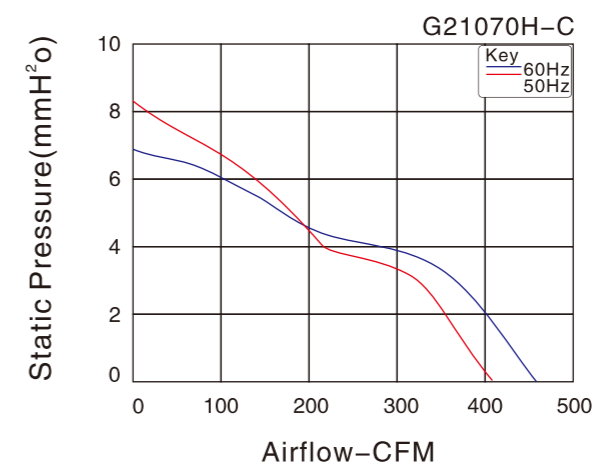

Fan Accessories



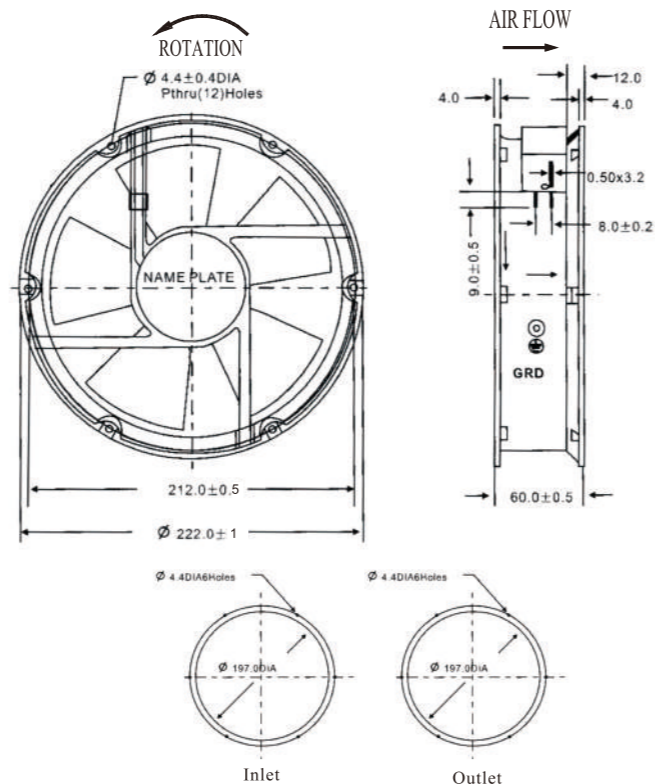

尺寸 Size:  $\varnothing 220\text{mm} \times 60\text{mm}$   
 风量 Airflow: 367~385CFM  
 重量 Weight: 1350g  
 噪音 Noise: 58~59dB(A)  
 风叶 Impeller Material: PBT UL94-V0 Reinforced Plastic  
 外框 Frame: Aluminum Alloy  
 端子 Terminals: 0.5mm  
 引线 Lead Wire: AWG#22 UL 1015(Optional)  
 马达 Motor: Shaded Pole Induction Motor  
 温度范围 Operating Temperature:  $-10^{\circ}\text{C} \sim +65^{\circ}\text{C}$

产品型号 Model	轴承型式 Bearing System	电压 Voltage VAC	频率 Freq. Hz	电流 Current A	功率 Power W	转速 Speed RPM	噪音 Noise dB(A)	风量 Air Flow CFM	相数 Phase	电容 Capacitor $\mu\text{F}/\text{VAC}$
G22060HA,B	Ball	100/125	50/60	1/0.93	67/67	2500/2450	58/59	385/367	1	—
G22060HA <sub>2</sub> B	Ball	200/240	50/60	0.32	48/48	2600/2800	58/59	385/367	1	—

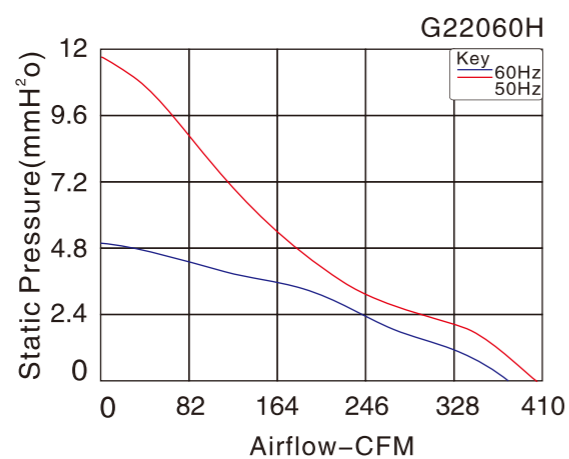

Fan Accessories

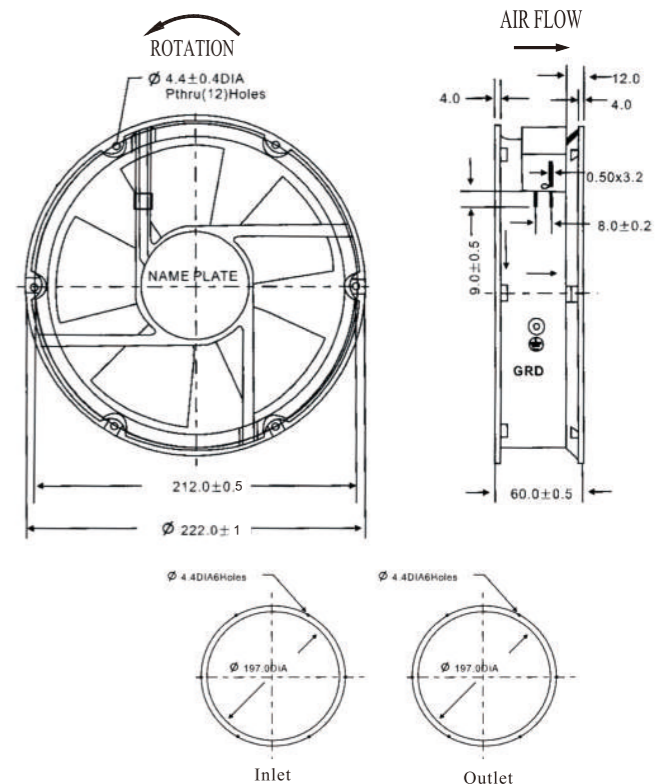
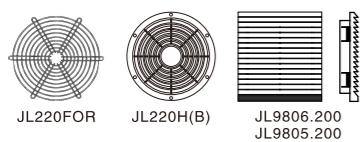

尺寸 Size:  $\varnothing 220\text{mm} \times 60\text{mm}$   
 风量 Airflow: 410~425CFM  
 重量 Weight: 1350g  
 噪音 Noise: 56~65dB(A)  
 风叶 Impeller Material: PBT UL94-V0 Reinforced Plastic  
 外框 Frame: Aluminum Alloy  
 端子 Terminals: 0.5mm  
 引线 Lead Wire: AWG#22 UL 1015(Optional)  
 马达 Motor: Capacitor-Run Induction Motor  
 温度范围 Operating Temperature:  $-10^{\circ}\text{C} \sim +65^{\circ}\text{C}$

产品型号 Model	轴承型式 Bearing System	电压 Voltage VAC	频率 Freq. Hz	电流 Current A	功率 Power W	转速 Speed RPM	噪音 Noise dB(A)	风量 Air Flow CFM	相数 Phase	电容 Capacitor $\mu\text{F}/\text{VAC}$
G22060HA,B-C	Ball	100/125	50/60	0.4/0.42	50/60	2650/2850	60/65	410/425	1	1.5/500
G22060HA <sub>2</sub> B-C	Ball	200/240	50/60	0.22/0.26	50/60	2650/2850	60/65	410/425	1	1/500
G22060HA <sub>3</sub> B-C	Ball	380/420	50/60	0.13/0.14	43/50	2650/2850	56/64	410/425	1	—
G22060HA <sub>4</sub> B-C	Ball	380/420	50/60	0.12/0.14	45/52	2650/2850	56/64	410/425	1	1/500

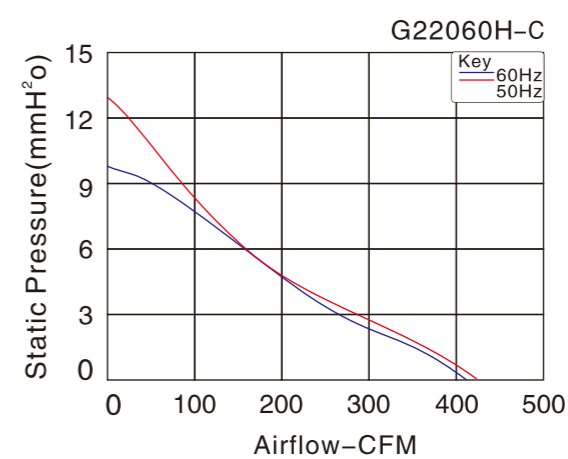

Fan Accessories

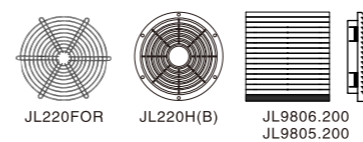

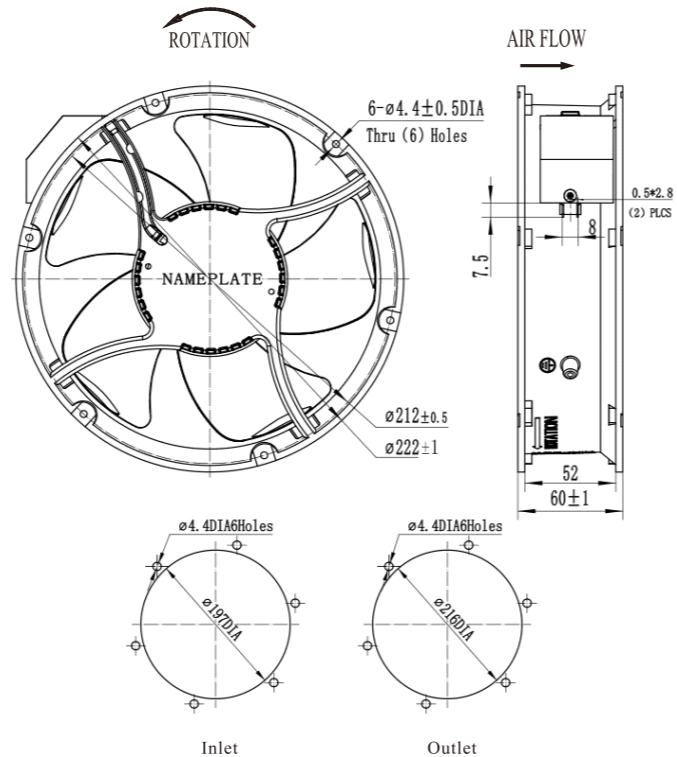

尺寸 Size: 220mm  $\times$  220mm  $\times$  60mm  
风量 Airflow: 357-386CFM  
重量 Weight: 1600g  
噪音 Noise: 63-67dB(A)  
风叶 Impeller Material: PBT UL94-V0 Reinforced Plastic  
外框 Frame: Aluminum Alloy  
端子 Terminals: Terminal block  
引线 Lead Wire: AWG#UL1332 22#(Optional)  
马达 Motor: Shaded Pole Induction Motor  
温度范围 Operating Temperature: -10 $^{\circ}$ C~+65 $^{\circ}$ C

产品型号 Model	轴承型式 Bearing System	电压 Voltage VAC	频率 Freq. Hz	电流 Current A	功率 Power W	转速 Speed RPM	噪音 Noise dB(A)	风量 Air Flow CFM	相数 Phase	电容 Capacitor $\mu$ F/VAC
G22060HA <sub>2</sub> BL	Ball	200/240	50/60	0.4/0.37	56/53	2800/3150	63/67	357/386	1	—

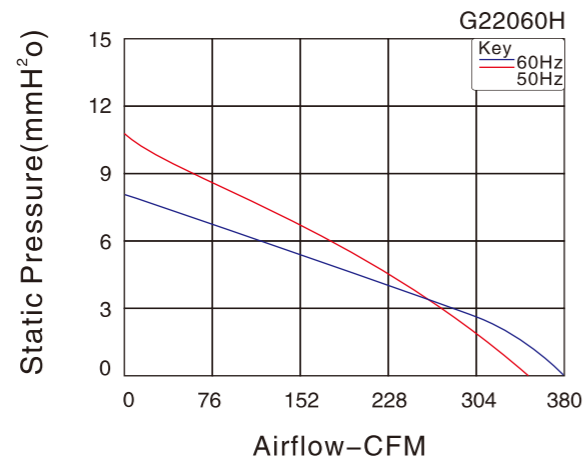

Fan Accessories

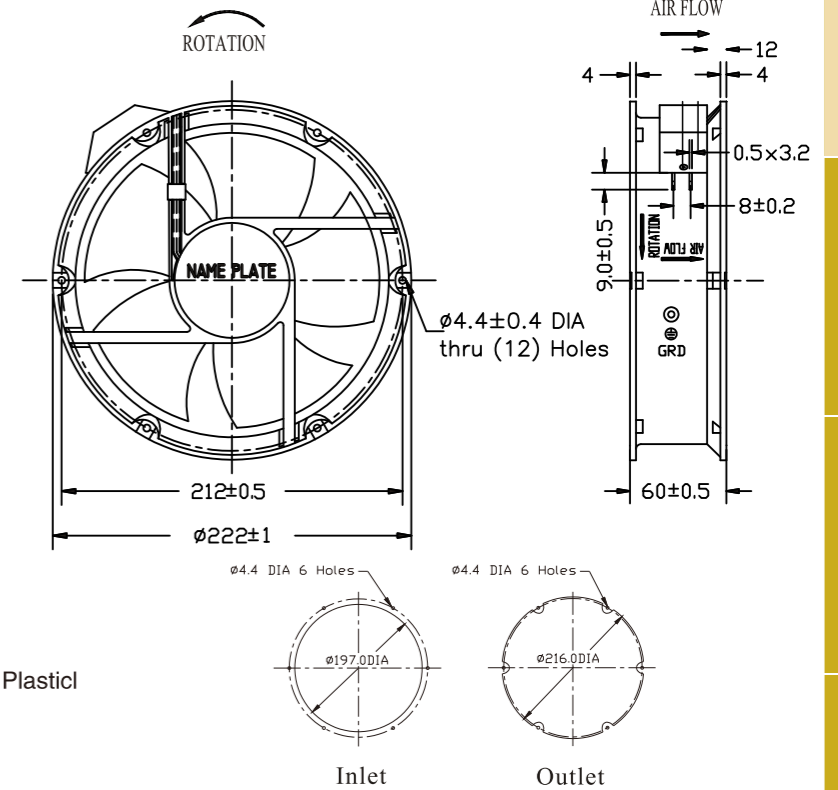
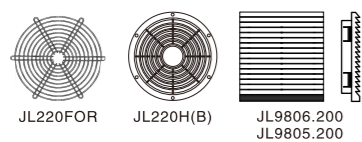

尺寸 Size:  $\phi$ 200mm  $\times$  60mm  
风量 Airflow: 477-515CFM  
重量 Weight: 1350g  
噪音 Noise: 59-62dB(A)  
风叶 Impeller Material: PBT UL94-V0 Reinforced Plastic  
外框 Frame: Aluminum Alloy  
端子 Terminals: 0.5mm  
引线 Lead Wire: AWG#22 UL 1015(Optional)  
马达 Motor: Capacitor-Run Induction Motor  
温度范围 Operating Temperature: -10 $^{\circ}$ C~+65 $^{\circ}$ C

产品型号 Model	轴承型式 Bearing System	电压 Voltage VAC	频率 Freq. Hz	电流 Current A	功率 Power W	转速 Speed RPM	噪音 Noise dB(A)	风量 Air Flow CFM	相数 Phase	电容 Capacitor $\mu$ F/VAC
G22060HA <sub>2</sub> B-C	Ball	100/125	50/60	0.42/0.46	50/60	2850/3150	59/62	477/515	1	3.3/500
G22060HA <sub>2</sub> B-C	Ball	200/240	50/60	0.25/0.32	50/70	2850/3150	59/62	477/515	1	1.8/500

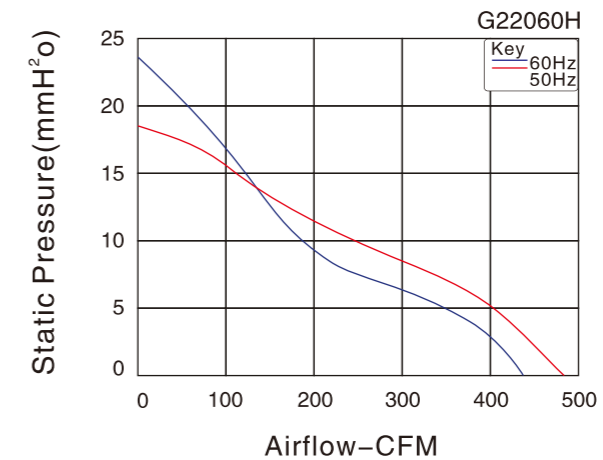

Fan Accessories

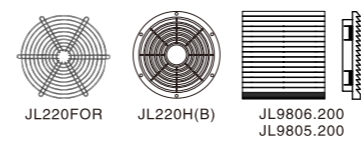

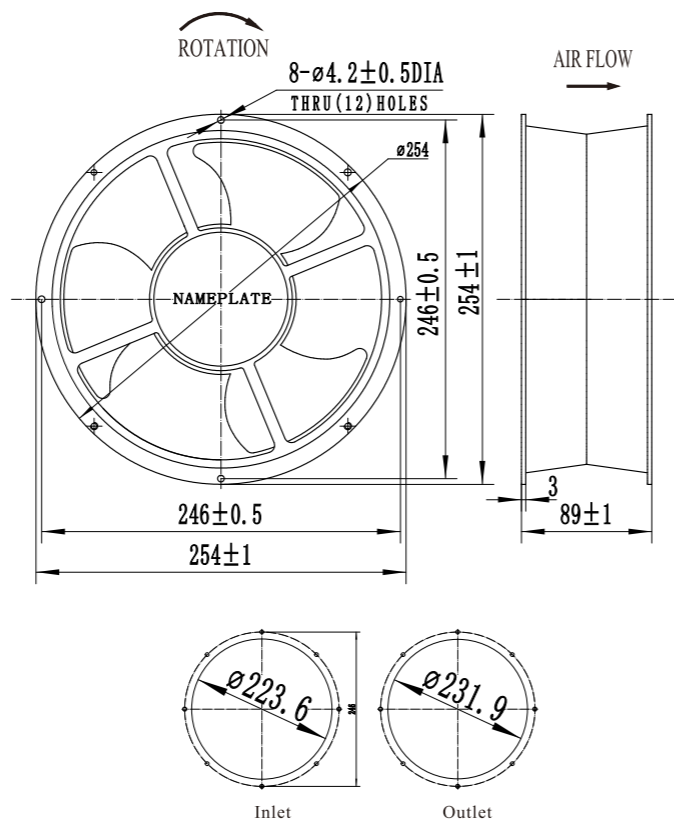

尺寸 Size:  $\phi 200$ mm  $\times$  89mm  
风量 Airflow: 600-880CFM  
重量 Weight: 2208g  
噪音 Noise: 60-70dB(A)  
风叶 Impeller Material: PBT UL94-V0 Reinforced Plastic  
外框 Frame: Aluminum Alloy  
端子 Terminals: 0.5mm  
引线 Lead Wire: AWG#22 UL 1015(Optional)  
马达 Motor: Capacitor-Run Induction Motor  
温度范围 Operating Temperature:  $-10^{\circ}\text{C} \sim +65^{\circ}\text{C}$

产品型号 Model	轴承型式 Bearing System	电压 Voltage VAC	频率 Freq. Hz	电流 Current A	功率 Power W	转速 Speed RPM	噪音 Noise dB(A)	风量 Air Flow CFM	电容 Capacitor $\mu\text{F/VAC}$
G2509HA,BL-C	Ball	100/125	50/60	0.7/0.85	95/100	2500/2850	68/70	810/880	8/250
G2509HA <sub>2</sub> ,BL-C	Ball	200/240	50/60	0.6/0.7	105/135	2500/2850	68/70	810/880	8/250
G2509MA,BL-C	Ball	100/125	50/60	0.6/0.65	75/85	2100/1900	62/60	665/600	8/250
G2509MA <sub>2</sub> ,BL-C	Ball	200/240	50/60	0.5/0.6	95/100	2100/1900	62/60	665/600	8/250

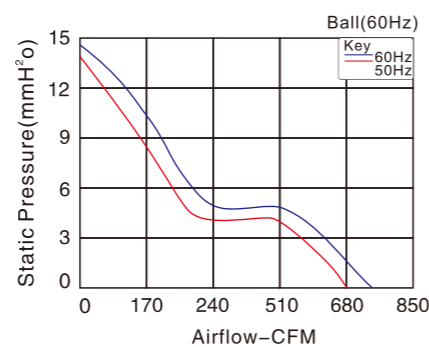
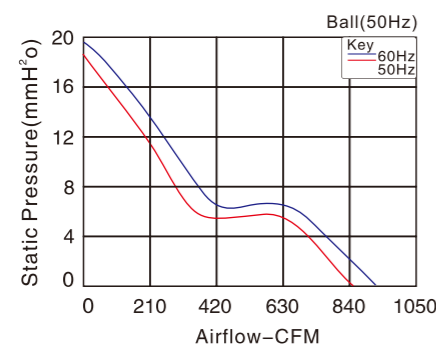

### Fan Accessories

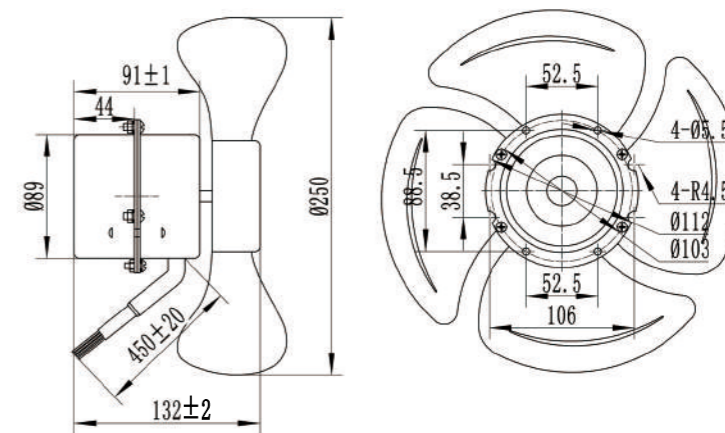
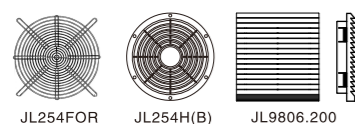

风量 Airflow: 635-735CFM  
重量 Weight: 2200g  
噪音 Noise: 60-65dB(A)  
风叶 Impeller Material: PA66  
外框 Frame: Aluminum Alloy  
端子 Terminals: 0.5mm  
引线 Lead Wire: AWG#24 UL 1332(Optional)  
马达 Motor: Capacitor-Run Induction Motor  
温度范围 Operating Temperature:  $-10^{\circ}\text{C} \sim +65^{\circ}\text{C}$

产品型号 Model	轴承型式 Bearing System	电压 Voltage VAC	频率 Freq. Hz	电流 Current A	功率 Power W	转速 Speed RPM	噪音 Noise dB(A)	风量 Air Flow CFM	相数 Phase	电容 Capacitor $\mu\text{F/VAC}$
FNZ-24-250(D <sub>2</sub> )	Ball	200/240	50/60	0.2	40	1400/1650	60/65	635/735	1	1.2/500
FNZ-24-250(D <sub>3</sub> )	Ball	380/420	50/60	0.2	40	1400/1650	60/65	635/735	1	0.47/500

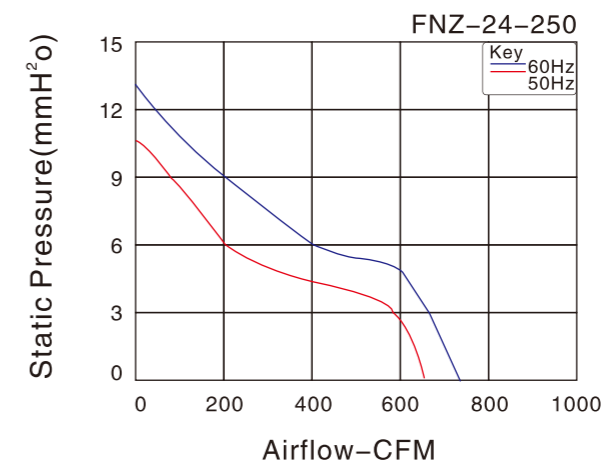

### Optional blades 可选风叶

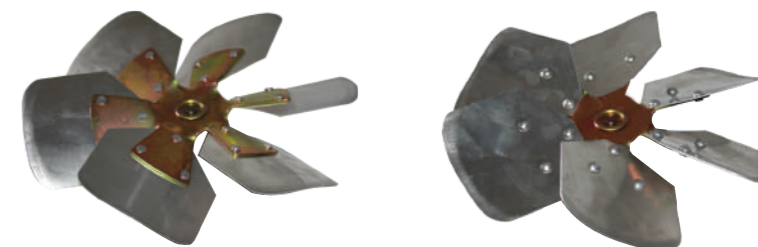

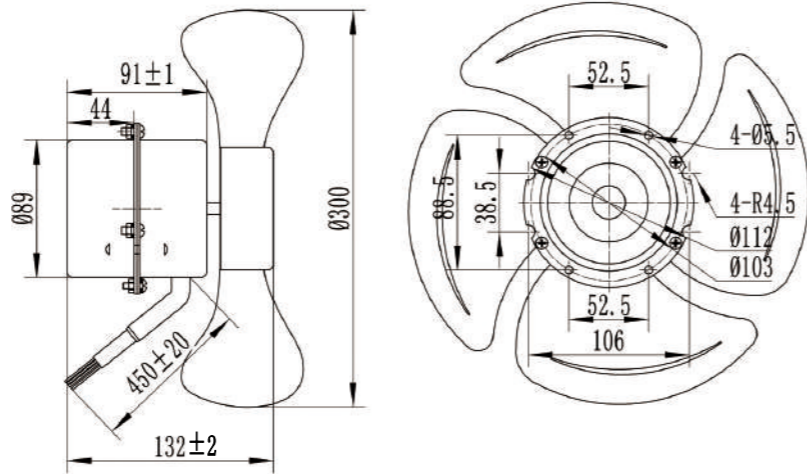

风量 Airflow: 800-963CFM  
重量 Weight: 2300g  
噪音 Noise: 63-68dB(A)  
风叶 Impeller Material: PA66  
外框 Frame: Aluminum Alloy  
端子 Terminals: 0.5mm  
引线 Lead Wire: AWG#22 UL 1332(Optional)  
马达 Motor: Capacitor-Run Induction Motor  
温度范围 Operating Temperature: -10°C~+65°C

产品型号 Model	轴承型式 Bearing System	电压 Voltage VAC	频率 Freq. Hz	电流 Current A	功率 Power W	转速 Speed RPM	噪音 Noise dB(A)	风量 Air Flow CFM	相数 Phase	电容 Capacitor $\mu$ F/VAC
FNZ-34-300(D <sub>2</sub> )	Ball	200/240	50/60	0.25	50	1400/1650	63/68	800/963	1	1.2/500
FNZ-34-300(D <sub>3</sub> )	Ball	380/420	50/60	0.25	50	1400/1650	63/68	800/963	1	0.47/500

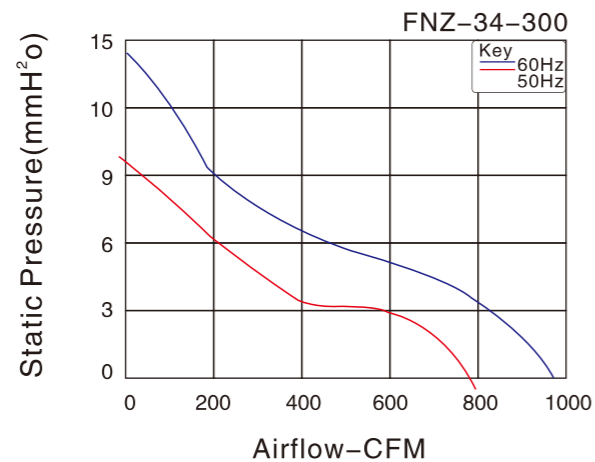

Optional blades  
可选风叶

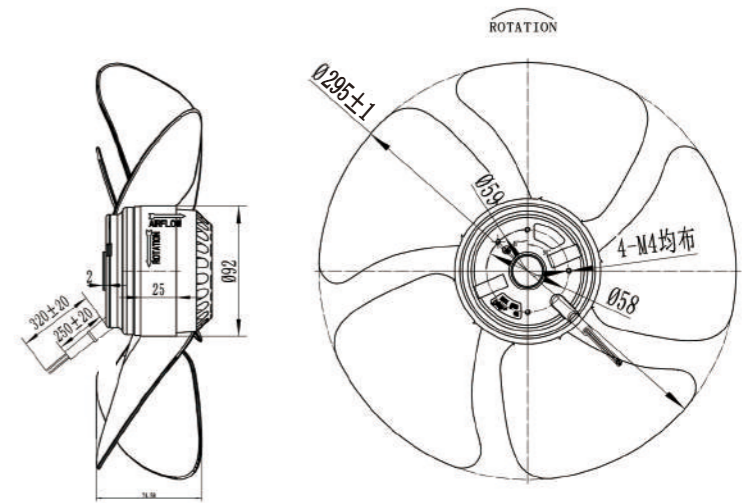

风量 Airflow: 867-977CFM  
重量 Weight: 2300g  
噪音 Noise: 58-61dB(A)  
风叶 Impeller Material: PA66  
外框 Frame: Aluminum Alloy  
端子 Terminals: 0.5mm  
引线 Lead Wire: AWG#22 UL 1332(Optional)  
马达 Motor: Capacitor-Run Induction Motor  
温度范围 Operating Temperature: -10°C~+65°C

产品型号 Model	轴承型式 Bearing System	电压 Voltage VAC	频率 Freq. Hz	电流 Current A	功率 Power W	转速 Speed RPM	噪音 Noise dB(A)	风量 Air Flow CFM	相数 Phase	电容 Capacitor $\mu$ F/VAC
300FZL1-S	Ball	100/125	50/60	0.65/0.85	75/95	1350/1500	58/61	867/977	1	3.3/500
300FZL2-S	Ball	200/240	50/60	0.31/0.40	70/90	1350/1500	58/61	867/977	1	1.5/500

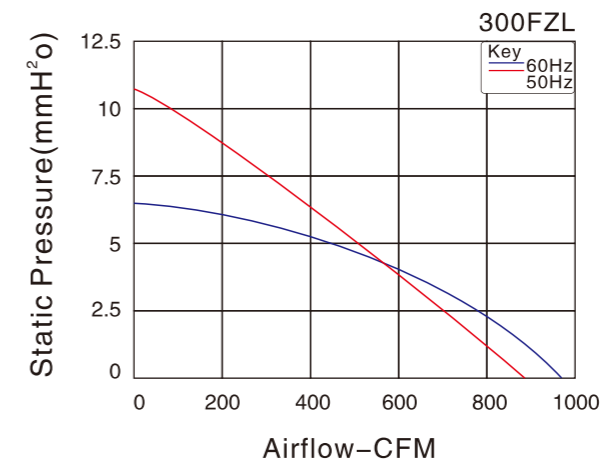

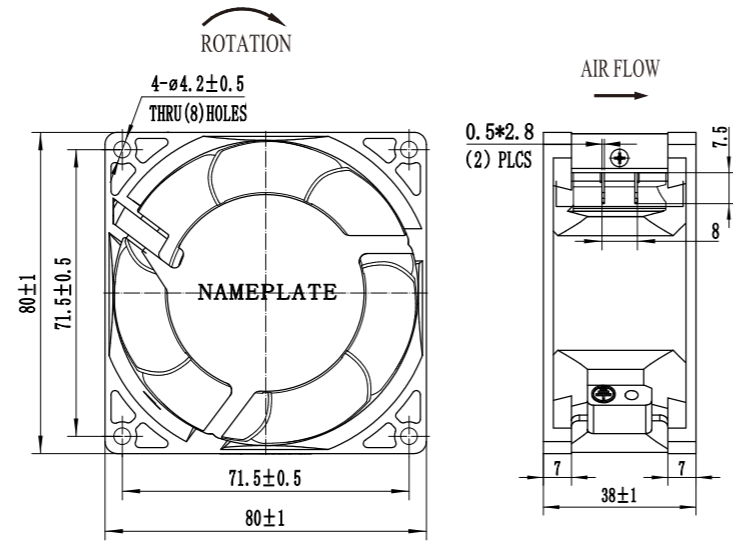

尺寸 Size: 80mm × 80mm × 38mm  
风量 Airflow: 28~34CFM  
重量 Weight: 403g  
噪音 Noise: 30~34dB(A)  
风叶 Impeller Material: Metal  
外框 Frame: Aluminum Alloy  
端子 Terminals: 0.5mm  
引线 Lead Wire: AWG#22UL 1322(Optional)  
马达 Motor: Shaded Pole And External Rotor Induction Motor  
温度范围 Operating Temperature: -10°C~+65°C

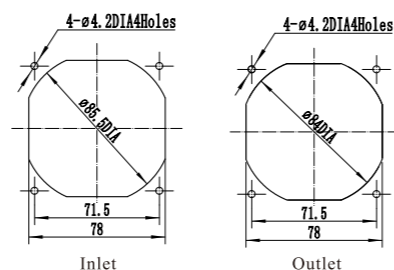

产品型号 Model	轴承型式 Bearing System	电压 Voltage VAC	频率 Freq. Hz	电流 Current A	功率 Power W	转速 Speed RPM	噪音 Noise dB(A)	风量 Air Flow CFM	相数 Phase	电容 Capacitor μF/VAC
TG8038HA <sub>2</sub> B-7P	Ball	100/125	50/60	0.18/0.15	14/11	2700/3250	30/34	28/34	1	—
TG8038HA <sub>2</sub> B-7P	Ball	200/240	50/60	0.09/0.1	16/14	2700/3250	30/34	28/34	1	—

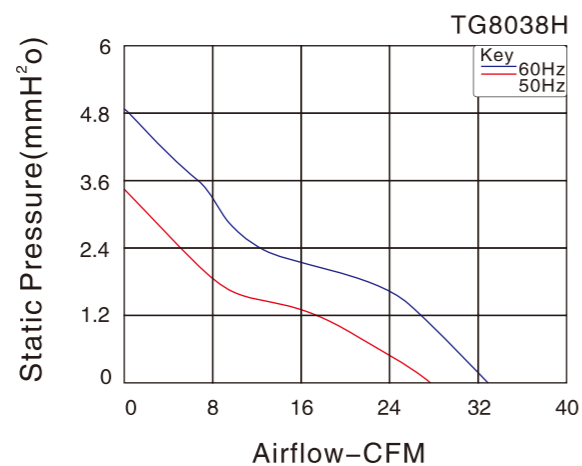

Fan Accessories

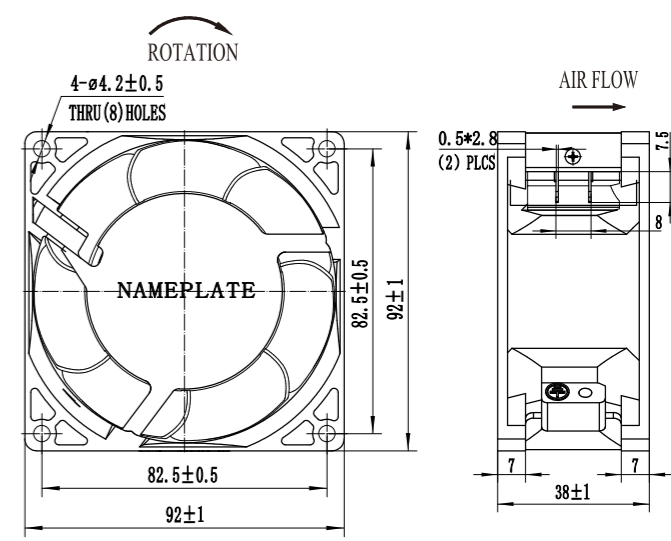
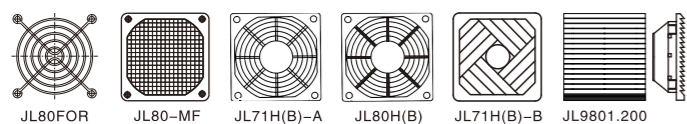

尺寸 Size: 92mm × 92mm × 38mm  
风量 Airflow: 46~56CFM  
重量 Weight: 480g  
噪音 Noise: 37~42dB(A)  
风叶 Impeller Material: Metal  
外框 Frame: Aluminum Alloy  
端子 Terminals: 0.5mm  
引线 Lead Wire: AWG#22UL 1332(Optional)  
马达 Motor: Shaded Pole And External Rotor Induction Motor  
温度范围 Operating Temperature: -10°C~+65°C

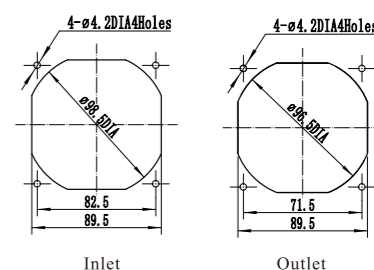

产品型号 Model	轴承型式 Bearing System	电压 Voltage VAC	频率 Freq. Hz	电流 Current A	功率 Power W	转速 Speed RPM	噪音 Noise dB(A)	风量 Air Flow CFM	相数 Phase	电容 Capacitor μF/VAC
TG9238HA <sub>2</sub> B-7P	Ball	100/125	50/60	0.18/0.18	16/14	2600/3000	37/42	46/56	1	—
TG9238HA <sub>2</sub> B-7P	Ball	200/240	50/60	0.1/0.09	16/14	2600/3000	37/42	46/56	1	—

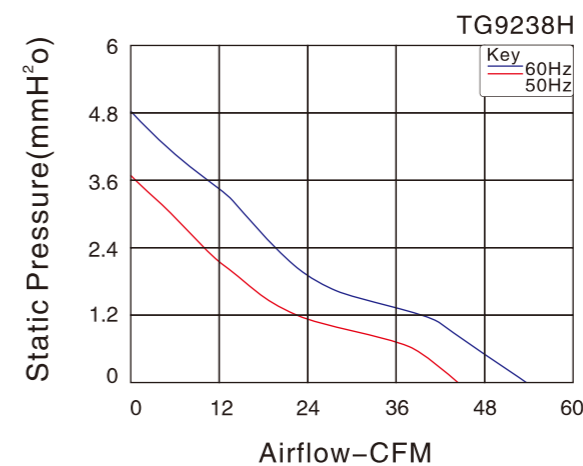

Fan Accessories

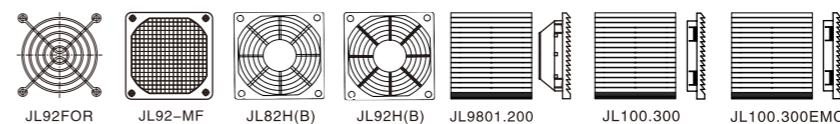

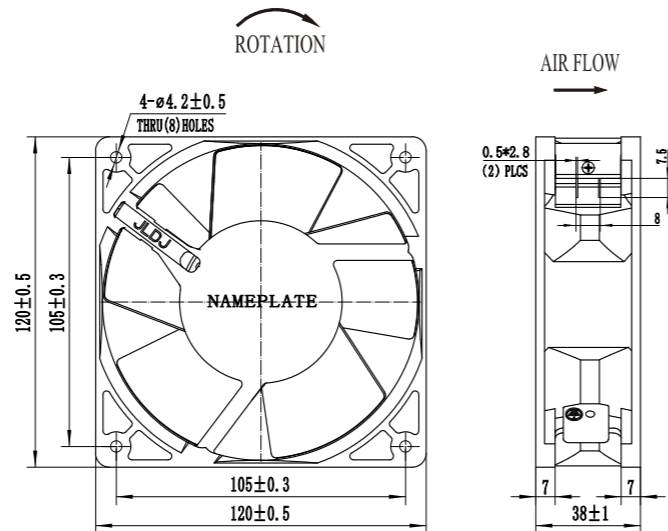

尺寸 Size: 120mm × 120mm × 38mm  
风量 Airflow: 97-111CFM  
重量 Weight: 600g  
噪音 Noise: 46-50dB(A)  
风叶 Impeller Material: Metal  
外框 Frame: Aluminum Alloy  
端子 Terminals: 0.5mm  
引线 Lead Wire: Teflon 22#UL 1322(Optional)  
马达 Motor: Shaded Pole And External Rotor Induction Motor  
温度范围 Operating Temperature: -10°C~+65°C

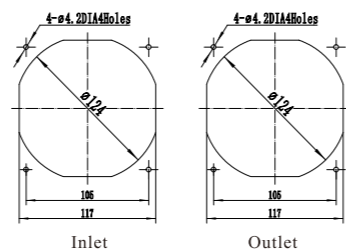

产品型号 Model	轴承型式 Bearing System	电压 Voltage VAC	频率 Freq. Hz	电流 Current A	功率 Power W	转速 Speed RPM	噪音 Noise dB(A)	风量 Air Flow CFM	相数 Phase	电容 Capacitor µF/VAC
TG12038HA,B	Ball	100/125	50/60	0.21/0.21	23/20	2600/3000	46/50	97/111	1	—
TG12038HA <sub>2</sub> B	Ball	200/240	50/60	0.15/0.13	23/20	2600/3000	46/50	97/111	1	—

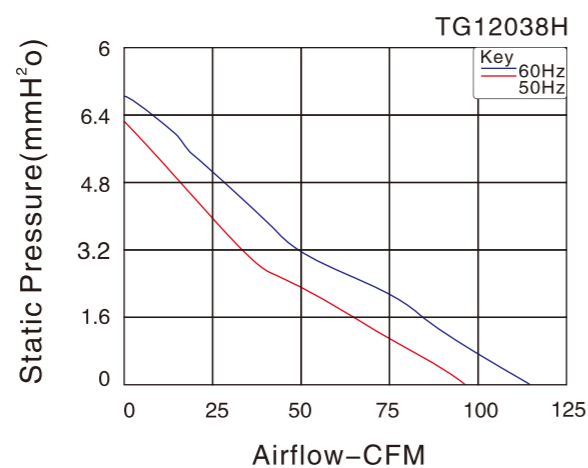

Fan Accessories

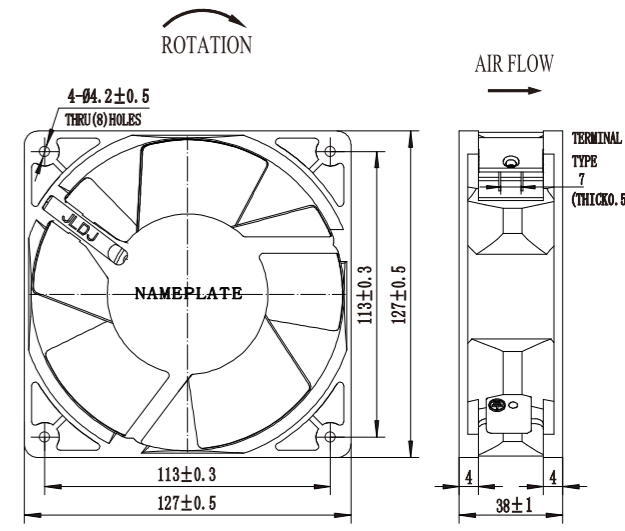
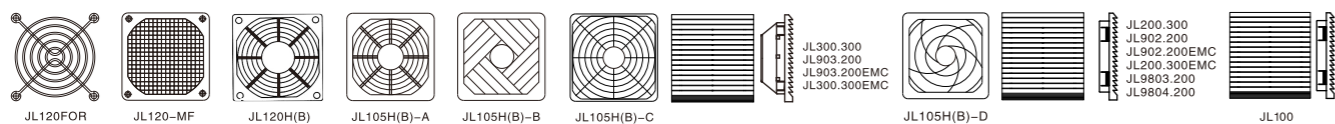

尺寸 Size: 127mm × 127mm × 38mm  
风量 Airflow: 120-134CFM  
重量 Weight: 650g  
噪音 Noise: 50-55dB(A)  
风叶 Impeller Material: Metal  
外框 Frame: Aluminum Alloy  
端子 Terminals: 0.5mm  
引线 Lead Wire: Teflon 22#UL 1332(Optional)  
马达 Motor: Shaded Pole And External Rotor Induction Motor  
温度范围 Operating Temperature: -10°C~+65°C

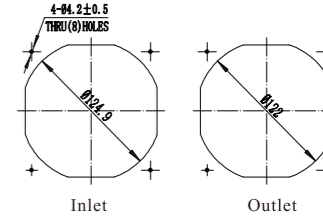

产品型号 Model	轴承型式 Bearing System	电压 Voltage VAC	频率 Freq. Hz	电流 Current A	功率 Power W	转速 Speed RPM	噪音 Noise dB(A)	风量 Air Flow CFM	相数 Phase	电容 Capacitor µF/VAC
TG12738HA,B	Ball	100/125	50/60	0.28	27	2600/3000	50/55	120/134	1	—
TG12738HA <sub>2</sub> B	Ball	200/240	50/60	0.16	25	2600/3000	50/55	120/134	1	—

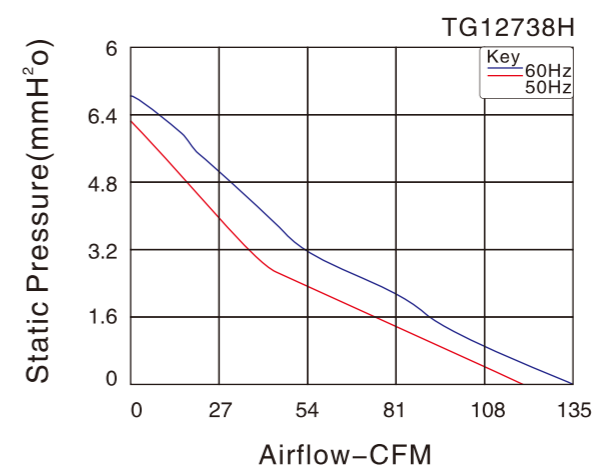

Fan Accessories

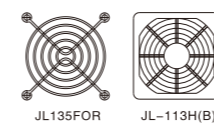

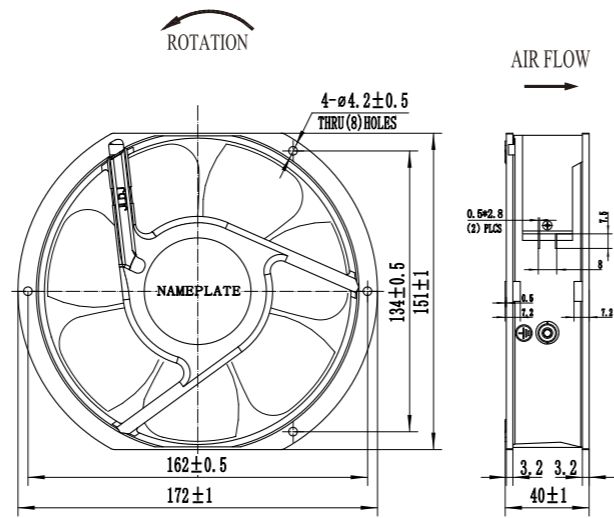

尺寸 Size: 172mm × 150mm × 40mm  
风量 Airflow: 214–250CFM  
重量 Weight: 860g  
噪音 Noise: 56–59dB(A)  
风叶 Impeller Material: Metal  
外框 Frame: Aluminum Alloy  
端子 Terminals: 0.5mm  
引线 Lead Wire: Teflon#22UL 1322(Optional)  
马达 Motor: Capacitor-Run And External Rotor Induction Motor  
温度范围 Operating Temperature: -10°C~+65°C

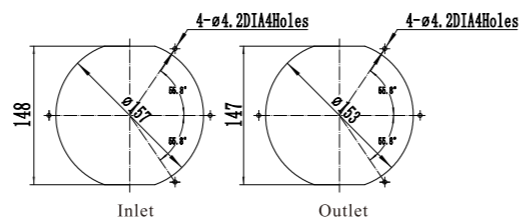

产品型号 Model	轴承型式 Bearing System	电压 Voltage VAC	频率 Freq. Hz	电流 Current A	功率 Power W	转速 Speed RPM	噪音 Noise dB(A)	风量 Air Flow CFM	相数 Phase	电容 Capacitor μF/VAC
TG17040HA,B	Ball	100/125	50/60	0.25/0.25	32	2500/2900	56/59	214/250	1	3.3/250
TG17040HA <sub>2</sub> B	Ball	200/240	50/60	0.14/0.14	32	2500/2900	56/59	214/250	1	1/500

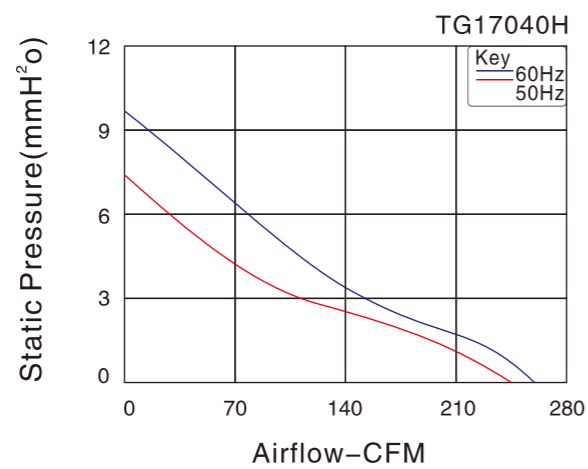

Fan Accessories

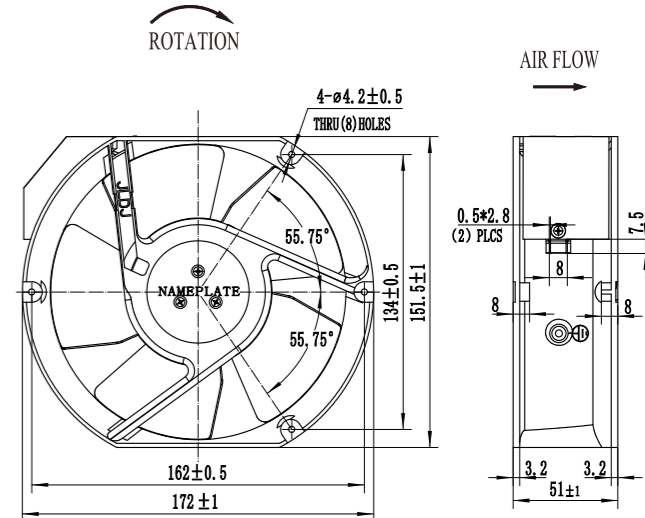
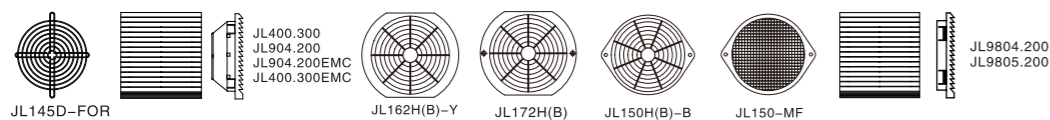

尺寸 Size: 172mm × 150mm × 51mm  
风量 Airflow: 249–278CFM  
重量 Weight: 900g  
噪音 Noise: 54–57dB(A)  
风叶 Impeller Material: Metal  
外框 Frame: Aluminum Alloy  
端子 Terminals: 0.5mm  
引线 Lead Wire: Teflon22#UL 1332(Optional)  
马达 Motor: Capacitor-Run And External Rotor Induction Motor  
温度范围 Operating Temperature: -10°C~+65°C

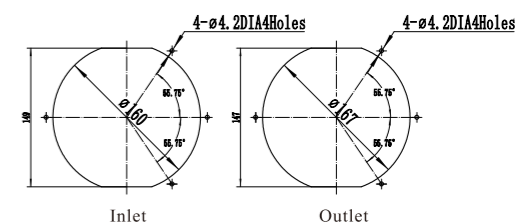

产品型号 Model	轴承型式 Bearing System	电压 Voltage VAC	频率 Freq. Hz	电流 Current A	功率 Power W	转速 Speed RPM	噪音 Noise dB(A)	风量 Air Flow CFM	相数 Phase	电容 Capacitor μF/VAC
TG17050HA,B	Ball	100/125	50/60	0.38/0.34	37/35	2750/3200	54/57	249/278	1	3.3/250
TG17050HA <sub>2</sub> B	Ball	200/240	50/60	0.13/0.15	29/33	2750/3200	54/57	249/278	1	1/500

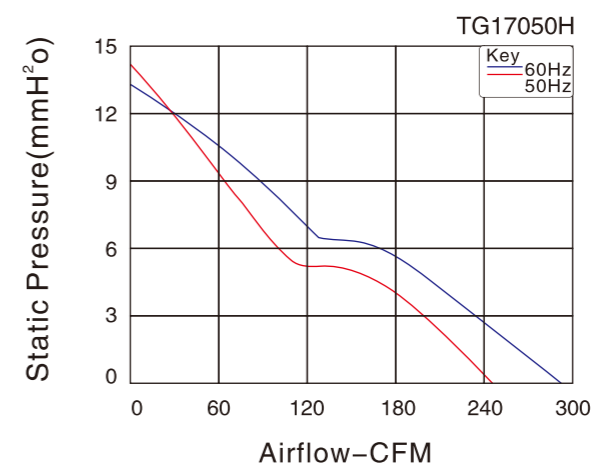

Fan Accessories

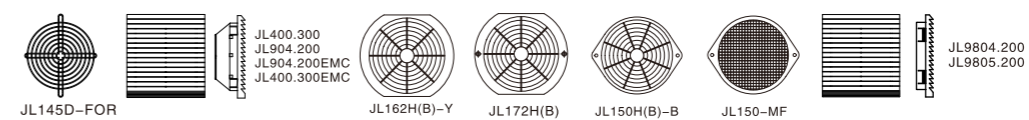

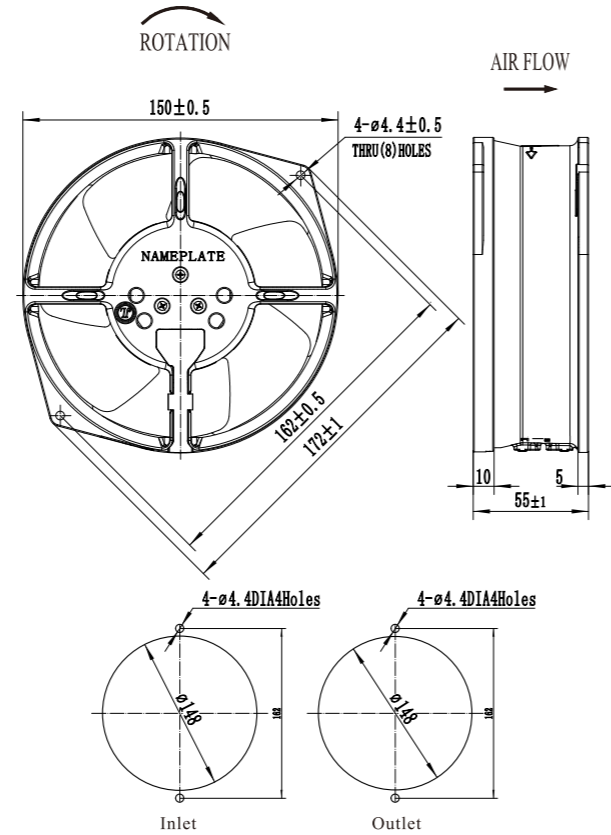

尺寸 Size: 172mm × 150mm × 55mm  
 风量 Airflow: 191–224CFM  
 重量 Weight: 1200g  
 噪音 Noise: 48–52dB(A)  
 风叶 Impeller Material: Metal  
 外框 Frame: Aluminum Alloy  
 端子 Terminals: 0.5mm  
 引线 Lead Wire: Teflon #22UL 1322(Optional)  
 马达 Motor: Shaded Pole And External Rotor Induction Motor  
 温度范围 Operating Temperature:  $-10^{\circ}\text{C} \sim +65^{\circ}\text{C}$

产品型号 Model	轴承型式 Bearing System	电压 Voltage VAC	频率 Freq. Hz	电流 Current A	功率 Power W	转速 Speed RPM	噪音 Noise dB(A)	风量 Air Flow CFM	相数 Phase	电容 Capacitor $\mu\text{F/VAC}$
TG17055HA,B-7P	Ball	100/125	50/60	0.58/0.5	42/39	2800/3100	48/52	191/224	1	—
TG17055HA,B-7P	Ball	200/240	50/60	0.25/0.2	35/31	2800/3100	48/52	191/224	1	—

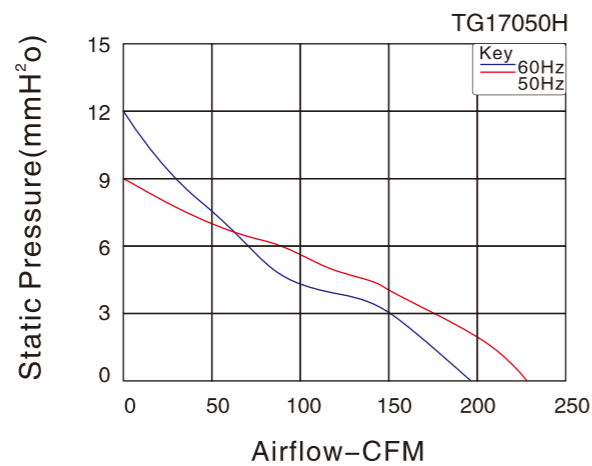

Fan Accessories

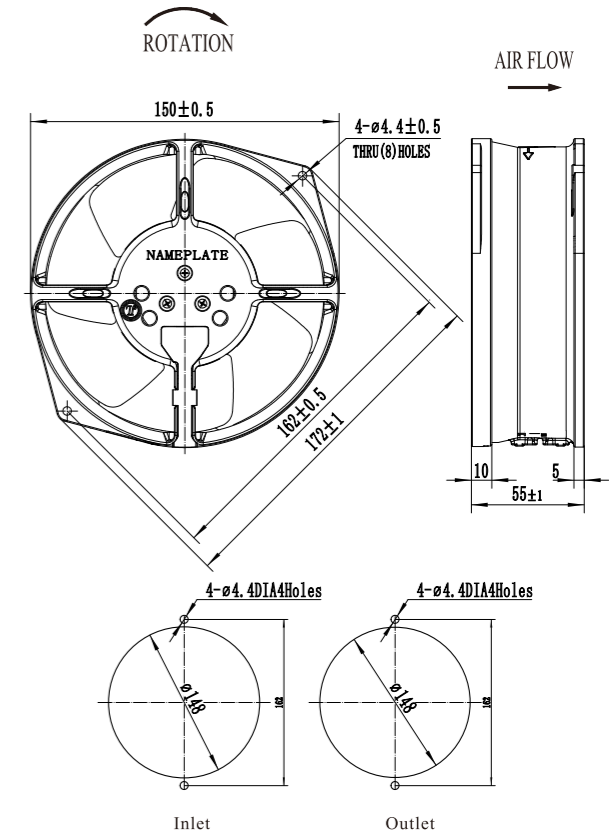
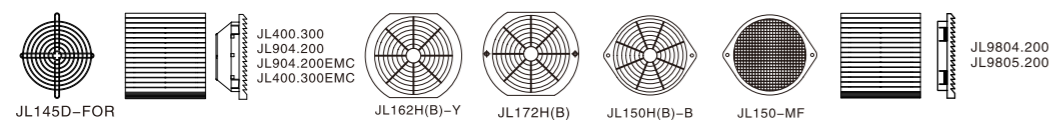

尺寸 Size: 172mm × 150mm × 55mm  
 风量 Airflow: 250–293CFM  
 重量 Weight: 1200g  
 噪音 Noise: 56–61dB(A)  
 风叶 Impeller Material: Metal  
 外框 Frame: Aluminum Alloy  
 端子 Terminals: 0.5mm  
 引线 Lead Wire: Teflon 22#UL 1332(Optional)  
 马达 Motor: Capacitor-Run And External Rotor Induction Motor  
 温度范围 Operating Temperature:  $-10^{\circ}\text{C} \sim +65^{\circ}\text{C}$

产品型号 Model	轴承型式 Bearing System	电压 Voltage VAC	频率 Freq. Hz	电流 Current A	功率 Power W	转速 Speed RPM	噪音 Noise dB(A)	风量 Air Flow CFM	相数 Phase	电容 Capacitor $\mu\text{F/VAC}$
TG17055HA,B-C-7P	Ball	100/125	50/60	0.35/0.40	46/50	2850/3300	56/61	250/293	1	3.3/250
TG17055HA,B-C-7P	Ball	200/240	50/60	0.20/0.22	46/50	2850/3300	56/61	250/293	1	1/500

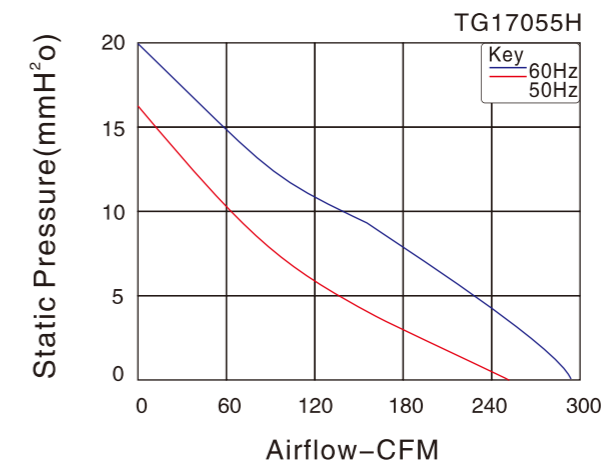

Fan Accessories

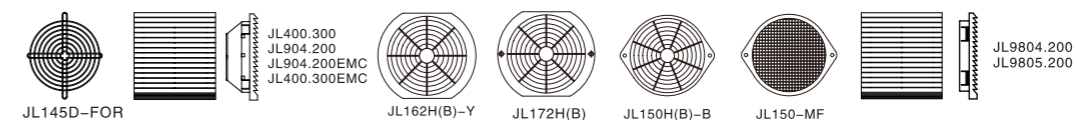

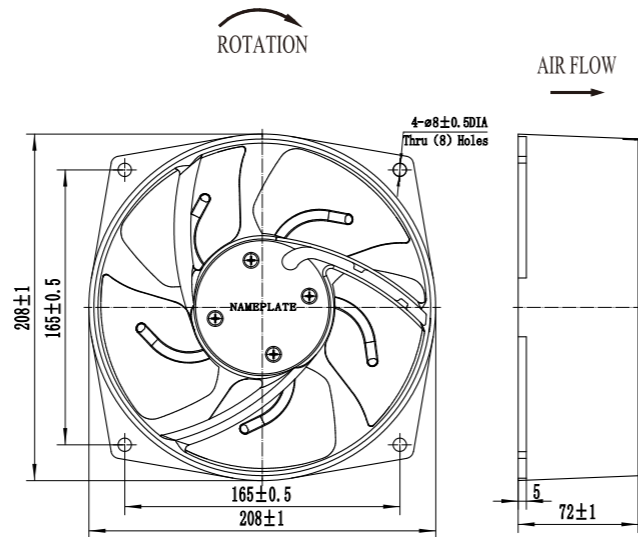

尺寸 Size: 208mm × 208mm × 72mm  
风量 Airflow: 506~577CFM  
重量 Weight: 1700g  
噪音 Noise: 58~60dB(A)  
风叶 Impeller Material: Metal  
外框 Frame: Aluminum Alloy  
端子 Terminals: 0.5mm  
引线 Lead Wire: Teflon 22#UL 1322(Optional)  
马达 Motor: Capacitor-Run And External Rotor Induction Motor  
温度范围 Operating Temperature: -10°C~+65°C

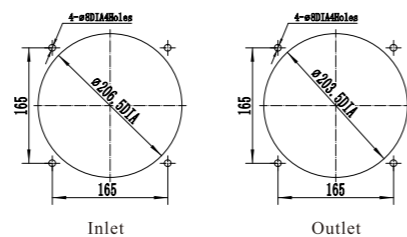

产品型号 Model	轴承型式 Bearing System	电压 Voltage VAC	频率 Freq. Hz	电流 Current A	功率 Power W	转速 Speed RPM	噪音 Noise dB(A)	风量 Air Flow CFM	相数 Phase	电容 Capacitor μF/VAC
TG200FZY2-D	Ball	200/240	50/60	0.32	65/70	2500/2900	58/60	506/577	1	2.2/500
TG200FZY7-D	Ball	380/420	50/60	0.26	79/70	2500/2900	58/60	506/577	1	1/500

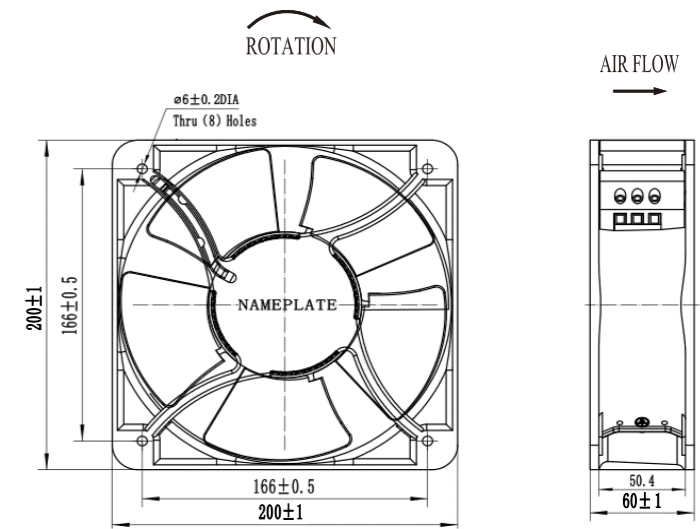
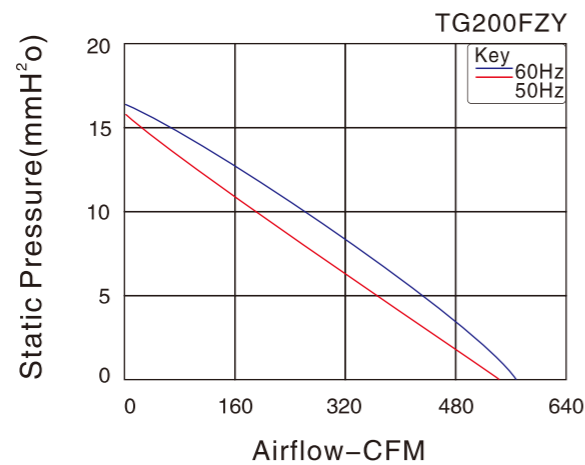

尺寸 Size: 200mm × 200mm × 60mm  
风量 Airflow: 427~490CFM  
重量 Weight: 1500g  
噪音 Noise: 63~68dB(A)  
风叶 Impeller Material: Aluminium Alloy  
外框 Frame: Aluminum Alloy  
端子 Terminals: Terminal block  
引线 Lead Wire: AWG#UL1332 22#(Optional)  
马达 Motor: Capacitor-Run Induction Motor  
温度范围 Operating Temperature: -10°C~+65°C

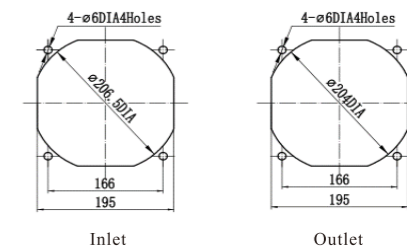

产品型号 Model	轴承型式 Bearing System	电压 Voltage VAC	频率 Freq. Hz	电流 Current A	功率 Power W	转速 Speed RPM	噪音 Noise dB(A)	风量 Air Flow CFM	相数 Phase	电容 Capacitor μF/VAC
TG20060HA <sub>1</sub> B-C	Ball	100/120	50/60	0.35/0.43	42/53	2800/3300	63/68	427/490	1	3.3/250
TG20060HA <sub>2</sub> B-C	Ball	200/240	50/60	0.18/0.25	42/53	2800/3300	63/68	427/490	1	1/500
TG20060HA <sub>3</sub> B-C	Ball	380/400	50/60	0.08/0.09	42/55	2800/3300	63/68	427/490	3	/
TG20060HA <sub>6</sub> B-C	Ball	380/400	50/60	0.08/0.09	42/55	2800/3300	63/68	427/490	1	1/500

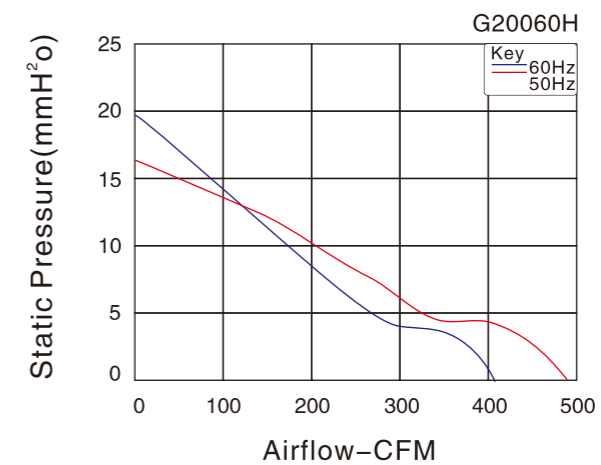

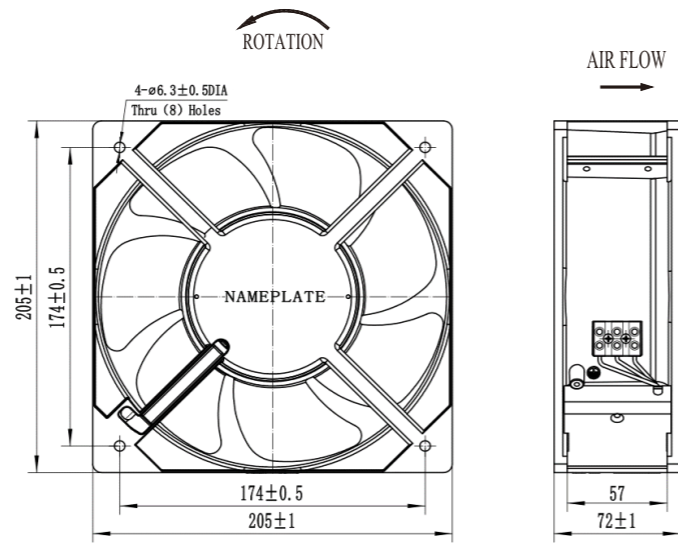

尺寸 Size: 205mm × 205mm × 72mm  
 风量 Airflow: 650-755CFM  
 重量 Weight: 2400g  
 噪音 Noise: 67-71dB(A)  
 风叶 Impeller Material: Aluminium Alloy  
 外框 Frame: Aluminum Alloy  
 端子 Terminals: Terminal block  
 引线 Lead Wire: AWG#UL1332 22#(Optional)  
 马达 Motor: Capacitor-Run Induction Motor  
 温度范围 Operating Temperature: -10°C~+65°C

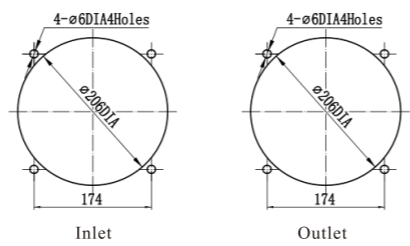

产品型号 Model	轴承型式 Bearing System	电压 Voltage VAC	频率 Freq. Hz	电流 Current A	功率 Power W	转速 Speed RPM	噪音 Noise dB(A)	风量 Air Flow CFM	相数 Phase	电容 Capacitor μF/VAC
TG20572HA <sub>1</sub> B-C	Ball	100/125	50/60	0.55/0.8	70/100	2900/3380	67/71	650/755	1	8/250
TG20572HA <sub>2</sub> B-C	Ball	200/240	50/60	0.3/0.42	67/92	2900/3380	67/71	650/755	1	3/500
TG20572HA <sub>3</sub> B-C	Ball	380/420	50/60	0.18/0.26	68/98	2900/3380	67/71	650/755	1	—
TG20572HA <sub>4</sub> B-C	Ball	380/420	50/60	0.18/0.26	68/98	2900/3380	67/71	650/755	1	1/500

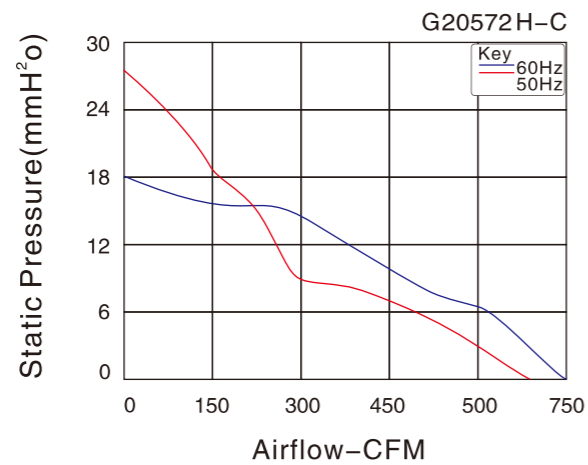

Fan Accessories

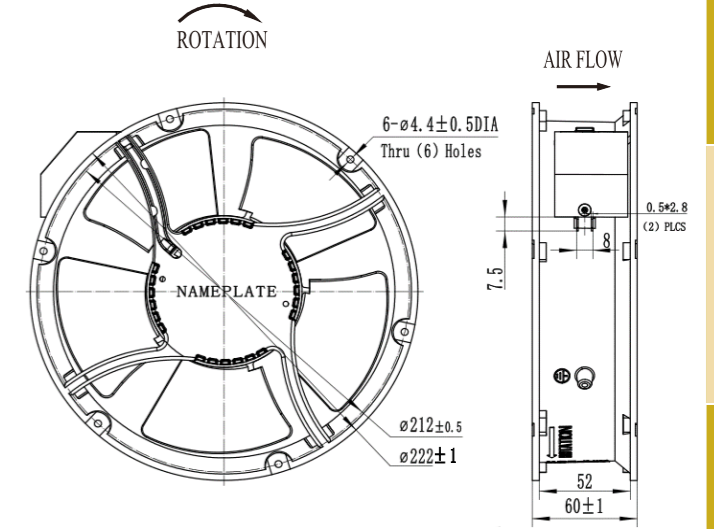
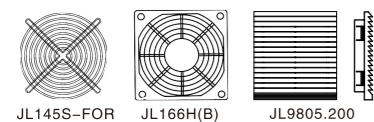

尺寸 Size: Ø220mm × 60mm  
 风量 Airflow: 427-490CFM  
 重量 Weight: 1560g  
 噪音 Noise: 63-68dB(A)  
 风叶 Impeller Material: Aluminium Alloy  
 外框 Frame: Aluminum Alloy  
 端子 Terminals: Terminal block  
 引线 Lead Wire: AWG#UL1332 22#(Optional)  
 马达 Motor: Capacitor-Run Induction Motor  
 温度范围 Operating Temperature: -10°C~+65°C

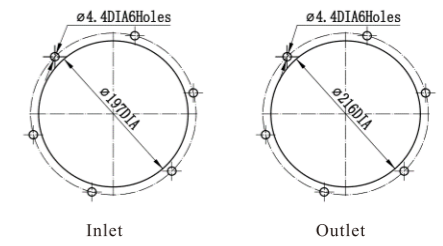

产品型号 Model	轴承型式 Bearing System	电压 Voltage VAC	频率 Freq. Hz	电流 Current A	功率 Power W	转速 Speed RPM	噪音 Noise dB(A)	风量 Air Flow CFM	相数 Phase	电容 Capacitor μF/VAC
G22060HA <sub>1</sub> B-C	Ball	100/120	50/60	0.35/0.43	40/48	2800/3300	63/68	427/490	1	3.3/500
G22060HA <sub>2</sub> B-C	Ball	200/240	50/60	0.18/0.25	45/53	2800/3300	63/68	427/490	1	1/500
G22060HA <sub>3</sub> B-C	Ball	380/400	50/60	0.08/0.09	42/55	2800/3300	63/68	427/490	3	—
G22060HA <sub>4</sub> B-C	Ball	380/400	50/60	0.08/0.09	42/55	2800/3300	63/68	427/490	1	1/500

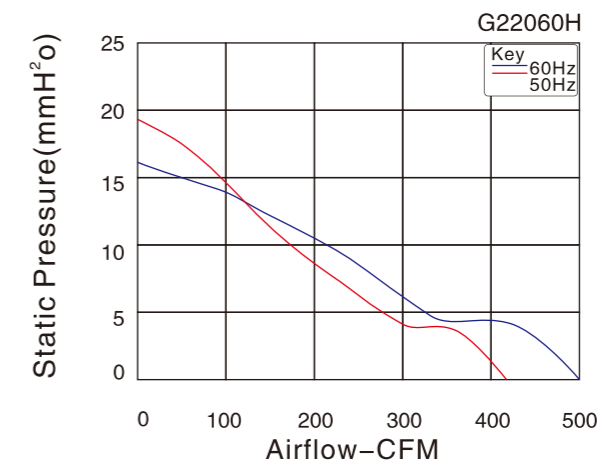

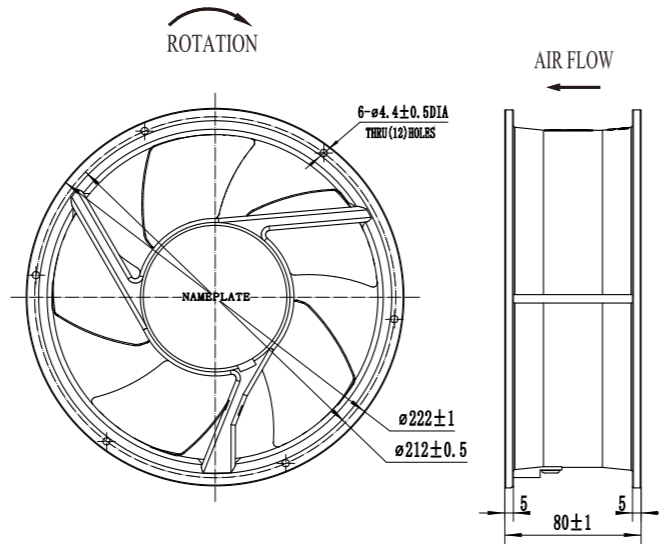

尺寸 Size:  $\Phi 220\text{mm} \times 80\text{mm}$   
 风量 Airflow: 560–634CFM  
 重量 Weight: 2000g  
 噪音 Noise: 59–61dB(A)  
 风叶 Impeller Material: Metal  
 外框 Frame: Aluminum Alloy  
 端子 Terminals: 0.5mm  
 引线 Lead Wire: Teflon 22#UL 1332(Optional)  
 马达 Motor: Capacitor-Run And External Rotor Induction Motor  
 温度范围 Operating Temperature:  $-10^{\circ}\text{C} \sim +65^{\circ}\text{C}$

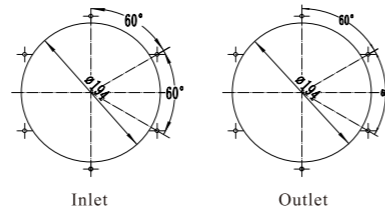

产品型号 Model	轴承型式 Bearing System	电压 Voltage VAC	频率 Freq. Hz	电流 Current A	功率 Power W	转速 Speed RPM	噪音 Noise dB(A)	风量 Air Flow CFM	相数 Phase	电容 Capacitor $\mu\text{F/VAC}$
TG22080HA <sub>1</sub> B-C	Ball	100/125	50/60	0.65/0.67	67/77	2650/3000	59/61	560/634	1	4/250
TG22080HA <sub>2</sub> B-C	Ball	200/240	50/60	0.28/0.35	65/71	2650/3000	59/61	560/634	1	2/500
TG22080HA <sub>3</sub> B	Ball	380/420	50/60	0.22/0.2	65/74	2650/3000	59/61	560/634	3	—
TG22080HA <sub>3</sub> B-C	Ball	380/420	50/60	0.25/0.33	65/74	2650/3000	59/61	560/634	1	1/500

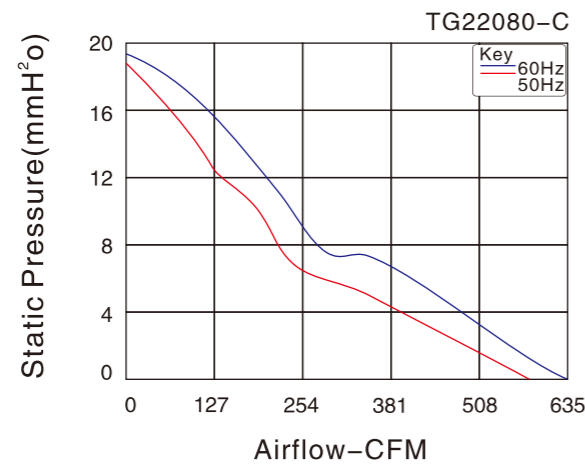

Fan Accessories



JL220FOR

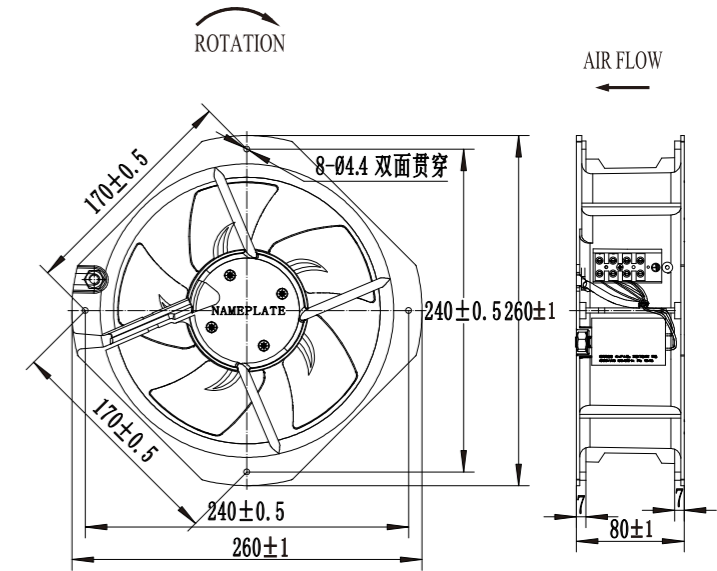

尺寸 Size:  $225\text{mm} \times 225\text{mm} \times 80\text{mm}$   
 风量 Airflow: 605–642CFM  
 重量 Weight: 2112g  
 噪音 Noise: 65–68dB(A)  
 风叶 Impeller Material: Metal  
 外框 Frame: Aluminum Alloy  
 端子 Terminals: 0.5mm  
 引线 Lead Wire: Teflon 22#UL 1332(Optional)  
 马达 Motor: Capacitor-Run And External Rotor Induction Motor  
 温度范围 Operating Temperature:  $-10^{\circ}\text{C} \sim +65^{\circ}\text{C}$

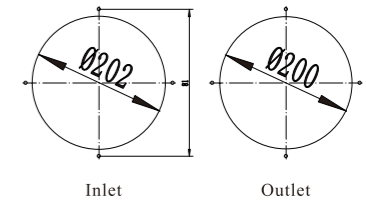

产品型号 Model	轴承型式 Bearing System	电压 Voltage VAC	频率 Freq. Hz	电流 Current A	功率 Power W	转速 Speed RPM	噪音 Noise dB(A)	风量 Air Flow CFM	相数 Phase	电容 Capacitor $\mu\text{F/VAC}$
TG22580HA <sub>1</sub> B-C	Ball	100/125	50/60	0.68/0.65	67/77	2550/2850	65/68	605/642	1	4/250
TG22580HA <sub>2</sub> B-C	Ball	200/240	50/60	0.35/0.28	60/80	2550/2850	65/68	605/642	1	2.2/500
TG22580HA <sub>3</sub> B	Ball	380/420	50/60	0.45/0.4	62/70	2550/2850	65/68	605/642	3	—
TG22580HA <sub>3</sub> B-C	Ball	380/420	50/60	0.16/0.19	62/74	2550/2850	65/68	605/642	1	1/500

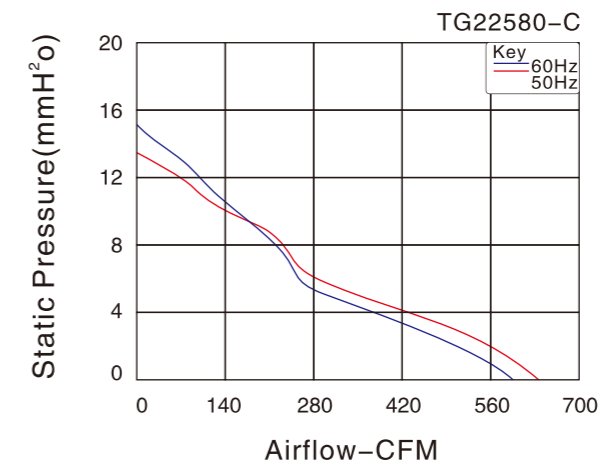

Fan Accessories

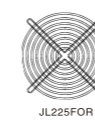

JL225FOR

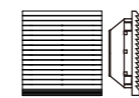

JL500.200  
JL905.200  
JL905.200EMC  
JL500.300EMC

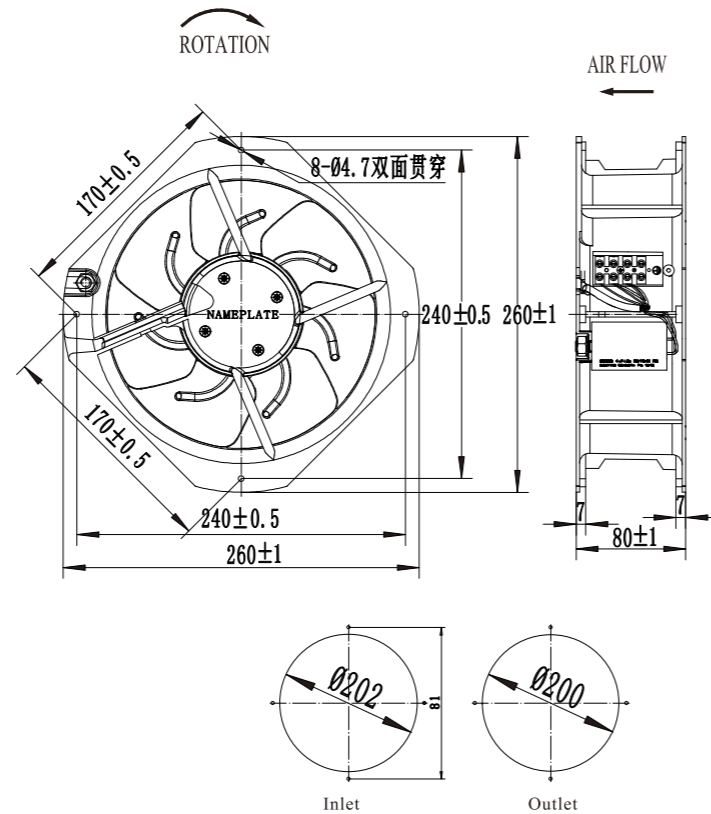

尺寸 Size: 225mm × 225mm × 80mm  
风量 Airflow: 597-661CFM  
重量 Weight: 2112g  
噪音 Noise: 59-61dB(A)  
风叶 Impeller Material: Metal  
外框 Frame: Aluminum Alloy  
端子 Terminals: 0.5mm  
引线 Lead Wire: Teflon 22#UL 1332(Optional)  
马达 Motor: Capacitor-Run And External Rotor Induction Motor  
温度范围 Operating Temperature: -10°C~+65°C

产品型号 Model	轴承型式 Bearing System	电压 Voltage VAC	频率 Freq. Hz	电流 Current A	功率 Power W	转速 Speed RPM	噪音 Noise dB(A)	风量 Air Flow CFM	相数 Phase	电容 Capacitor µF/VAC
TG22580HA,B-C-7P	Ball	100/125	50/60	0.68/0.65	60/72	2700/3100	59/61	597/661	1	4/250
TG22580HA,B-C-7P	Ball	200/240	50/60	0.25/0.33	54/71	2700/3100	59/61	597/661	1	2.2/500
TG22580HA,B-7P	Ball	380/420	50/60	0.25	50	2700/3100	59/61	597/661	3	/
TG22580HA,B-C-7P	Ball	380/420	50/60	0.23/0.2	68/76	2700/3100	59/61	597/661	1	1/500

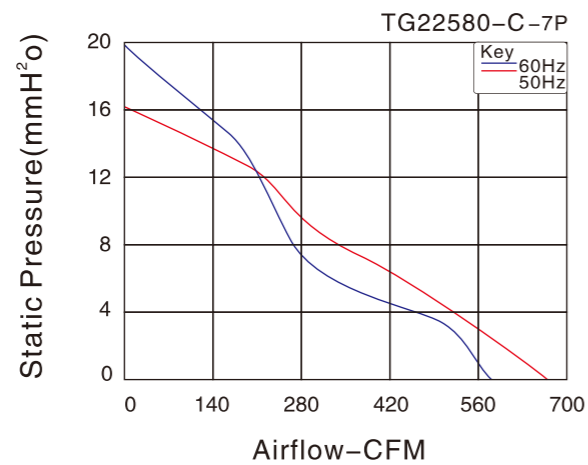

Fan Accessories

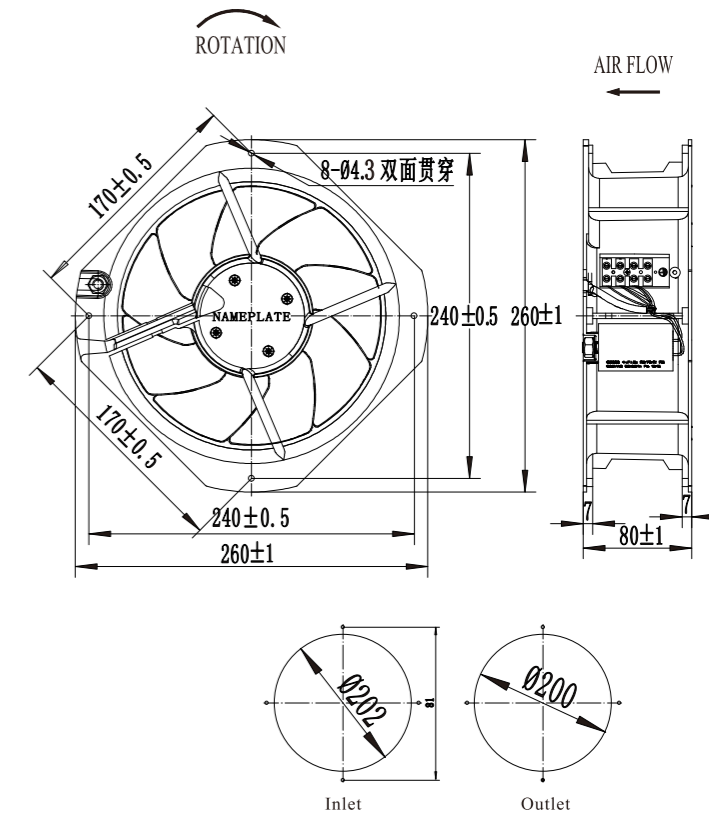
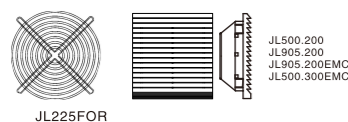

尺寸 Size: 225mm × 225mm × 80mm  
风量 Airflow: 585-625CFM  
重量 Weight: 2150g  
噪音 Noise: 59-61dB(A)  
风叶 Impeller Material: Metal  
外框 Frame: Aluminum Alloy  
端子 Terminals: 0.5mm  
引线 Lead Wire: Teflon 22#UL 1332(Optional)  
马达 Motor: Capacitor-Run And External Rotor Induction Motor  
温度范围 Operating Temperature: -10°C~+65°C

产品型号 Model	轴承型式 Bearing System	电压 Voltage VAC	频率 Freq. Hz	电流 Current A	功率 Power W	转速 Speed RPM	噪音 Noise dB(A)	风量 Air Flow CFM	相数 Phase	电容 Capacitor µF/VAC
TG22580HA,B-C-9P	Ball	100/125	50/60	0.68/0.65	67/77	2600/2800	59/61	585/625	1	4/250
TG22580HA,B-C-9P	Ball	200/240	50/60	0.35/0.28	57/76	2600/2800	59/61	585/625	1	2.2/500
TG22580HA,B-9P	Ball	380/420	50/60	0.25	65	2600/2800	59/61	585/625	3	/
TG22580HA,B-C-9P	Ball	380/420	50/60	0.25	65	2600/2800	59/61	585/625	1	1/500

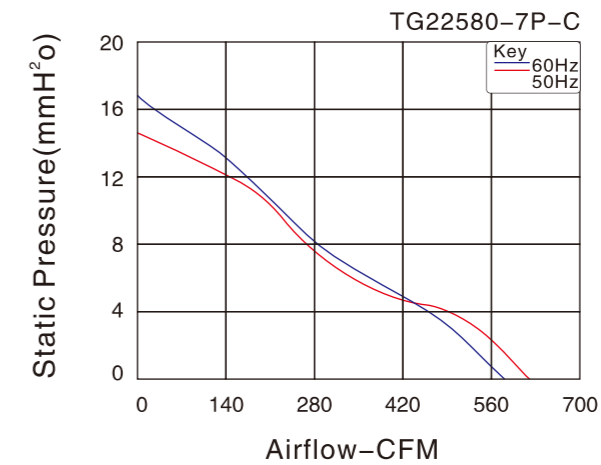

Fan Accessories

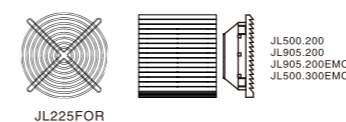

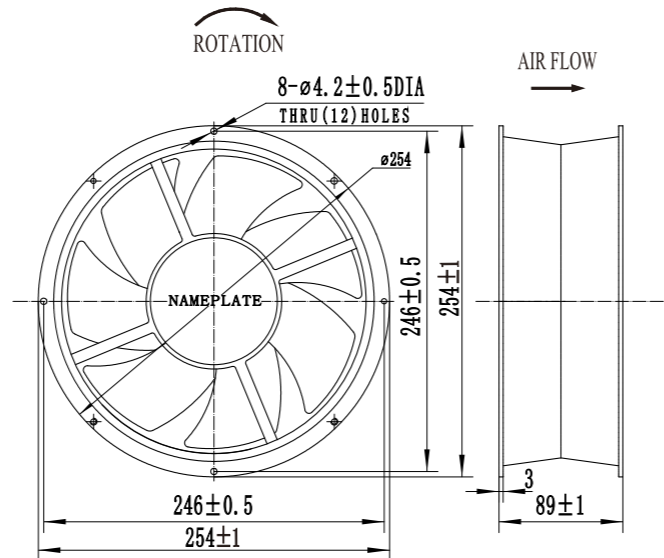

尺寸 Size:  $\phi 254\text{mm} \times 89\text{mm}$   
 风量 Airflow: 955-993CFM  
 重量 Weight: 2600g  
 噪音 Noise: 68-70dB(A)  
 风叶 Impeller Material: Metal  
 外框 Frame: Aluminum Alloy  
 端子 Terminals: 0.5mm  
 引线 Lead Wire: Teflon 22#UL 1332(Optional)  
 马达 Motor: Capacitor-Run And External Rotor Induction Motor  
 温度范围 Operating Temperature:  $-10^{\circ}\text{C} \sim +65^{\circ}\text{C}$

产品型号 Model	轴承型式 Bearing System	电压 Voltage VAC	频率 Freq. Hz	电流 Current A	功率 Power W	转速 Speed RPM	噪音 Noise dB(A)	风量 Air Flow CFM	相数 Phase	电容 Capacitor $\mu\text{F/VAC}$
TG25489HA,B-C-7P	Ball	100/125	50/60	0.98/1.15	67/77	2500/2650	68/70	955/993	1	4/250
TG25489HA,B-C-7P	Ball	200/240	50/60	0.56/0.74	124/161	2500/2650	68/70	955/993	1	2.2/500
TG25489HA,B-7P	Ball	380/420	50/60	0.3/0.4	108/132	2500/2650	68/70	955/993	3	—
TG25489HA,B-C-7P	Ball	380/420	50/60	0.28/0.34	108/132	2500/2650	68/70	955/993	1	1/500

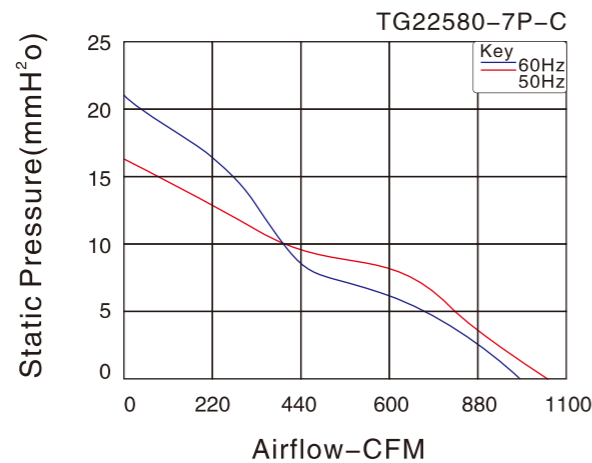

Fan Accessories

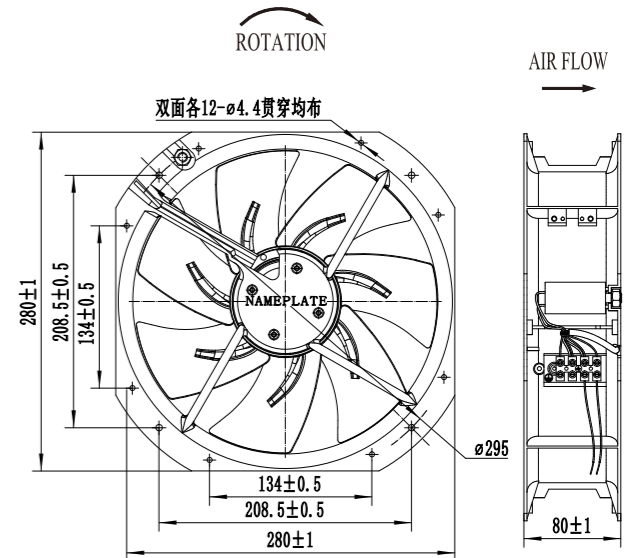
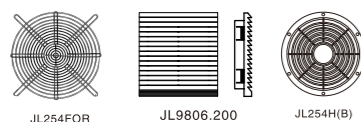

尺寸 Size:  $280\text{mm} \times 280\text{mm} \times 80\text{mm}$   
 风量 Airflow: 1098-1160CFM  
 重量 Weight: 2803g  
 噪音 Noise: 69-70dB(A)  
 风叶 Impeller Material: Metal  
 外框 Frame: Aluminum Alloy  
 端子 Terminals: 0.5mm  
 引线 Lead Wire: Teflon 22#UL 1332(Optional)  
 马达 Motor: Capacitor-Run And External Rotor Induction Motor  
 温度范围 Operating Temperature:  $-10^{\circ}\text{C} \sim +65^{\circ}\text{C}$

产品型号 Model	轴承型式 Bearing System	电压 Voltage VAC	频率 Freq. Hz	电流 Current A	功率 Power W	转速 Speed RPM	噪音 Noise dB(A)	风量 Air Flow CFM	相数 Phase	电容 Capacitor $\mu\text{F/VAC}$
TG28080HA,B-C	Ball	100/125	50/60	1.2/1.3	126/148	2500/2800	69/70	1098/1160	1	2.8/250
TG28080HA,B-C	Ball	200/240	50/60	0.58/0.63	126/148	2500/2800	69/70	1098/1160	1	4/500
TG28080HA,B	Ball	380/420	50/60	0.75/0.9	120/136	2500/2800	69/70	1098/1160	3	—
TG28080HA,B-C	Ball	380/420	50/60	0.24/0.25	120/136	2500/2800	69/70	1098/1160	1	2/500

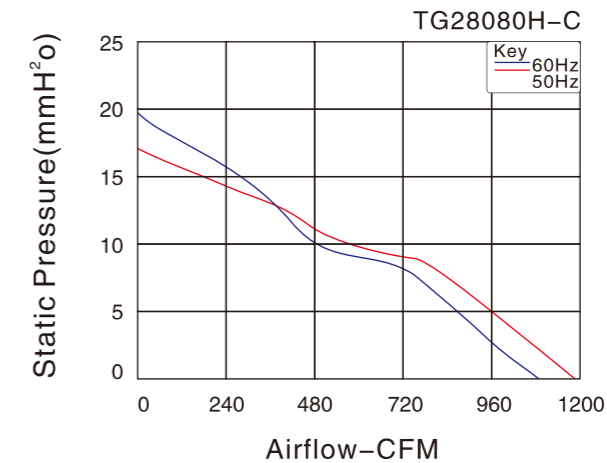

Fan Accessories

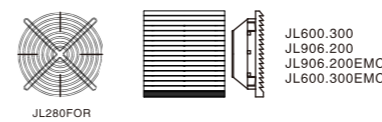

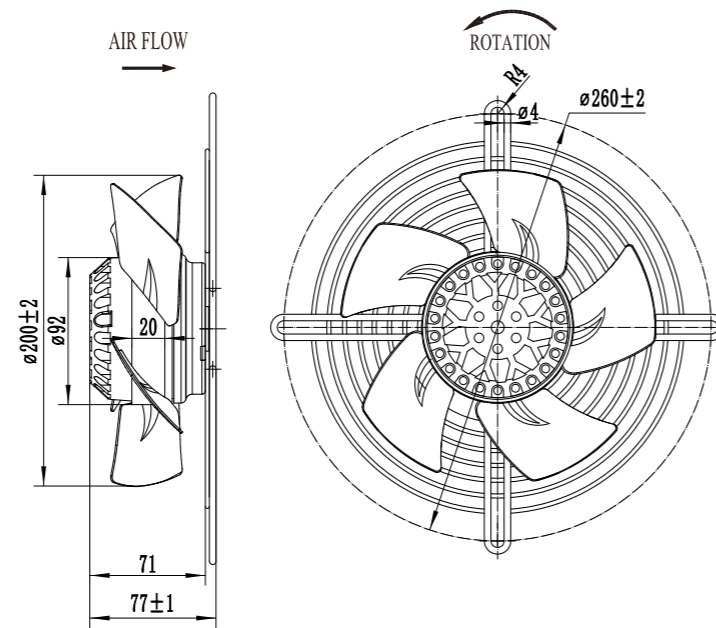
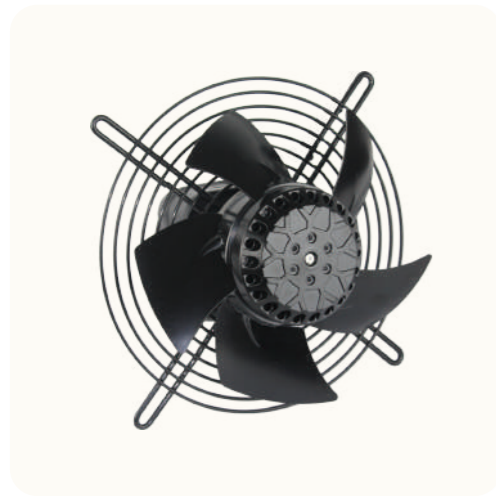

风量 Airflow: 605-642CFM  
重量 Weight: 1500g  
噪音 Noise: 65-68dB(A)  
风叶 Impeller Material: Metal  
外框 Frame: Metal guard  
端子 Terminals: 0.5mm  
引线 Lead Wire: Teflon22#UL 1332(Optional)  
马达 Motor: Capacitor-Run And External Rotor Induction Motor  
温度范围 Operating Temperature: -10°C~+65°C

产品型号 Model	轴承型式 Bearing System	电压 Voltage VAC	频率 Freq. Hz	电流 Current A	功率 Power W	转速 Speed RPM	噪音 Noise dB(A)	风量 Air Flow CFM	相数 Phase	电容 Capacitor μF/VAC
200FZL5	Ball	100/125	50/60	0.68/0.65	67/77	2550/2850	65/68	605/642	1	4/250
200FZL6	Ball	200/240	50/60	0.35/0.28	60/80	2550/2850	65/68	605/642	1	2.2/500
200FZL7	Ball	380/420	50/60	0.45/0.4	62/70	2550/2850	65/68	605/642	3	—
200FZL8	Ball	380/420	50/60	0.16/0.19	62/74	2550/2850	65/68	605/642	1	1/500

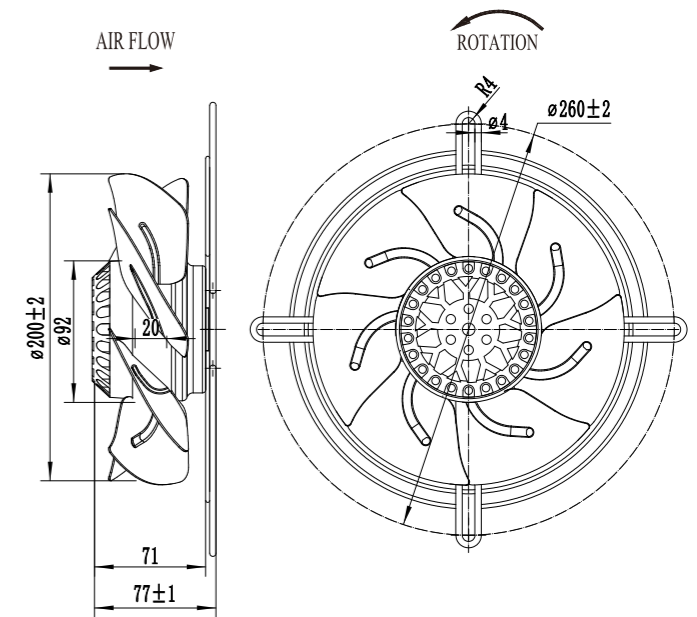
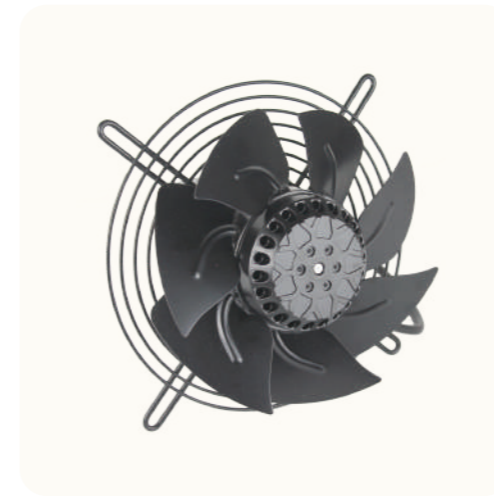
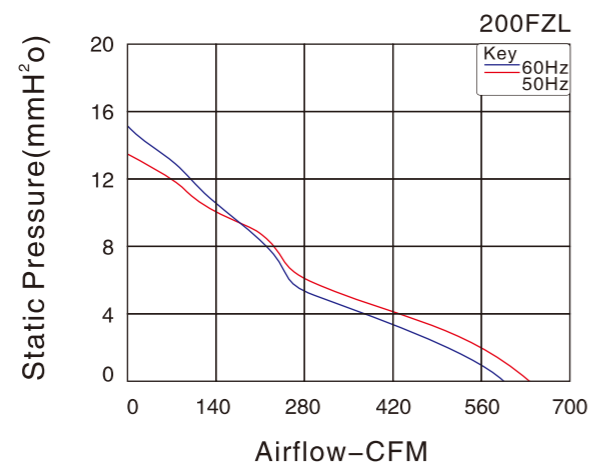

风量 Airflow: 597-661CFM  
重量 Weight: 1600g  
噪音 Noise: 59-61dB(A)  
风叶 Impeller Material: Metal  
外框 Frame: Metal guard  
端子 Terminals: 0.5mm  
引线 Lead Wire: Teflon22#UL 1332(Optional)  
马达 Motor: Capacitor-Run And External Rotor Induction Motor  
温度范围 Operating Temperature: -10°C~+65°C

产品型号 Model	轴承型式 Bearing System	电压 Voltage VAC	频率 Freq. Hz	电流 Current A	功率 Power W	转速 Speed RPM	噪音 Noise dB(A)	风量 Air Flow CFM	相数 Phase	电容 Capacitor μF/VAC
200FZL5-7P	Ball	100/125	50/60	0.68/0.65	60/72	2700/3100	59/61	597/661	1	4/250
200FZL6-7P	Ball	200/240	50/60	0.25/0.33	54/71	2700/3100	59/61	597/661	1	2.2/500
200FZL7-7P	Ball	380/420	50/60	0.25	50	2700/3100	59/61	597/661	3	—
200FZL8-7P	Ball	380/420	50/60	0.23/0.2	68/76	2700/3100	59/61	597/661	1	1/500

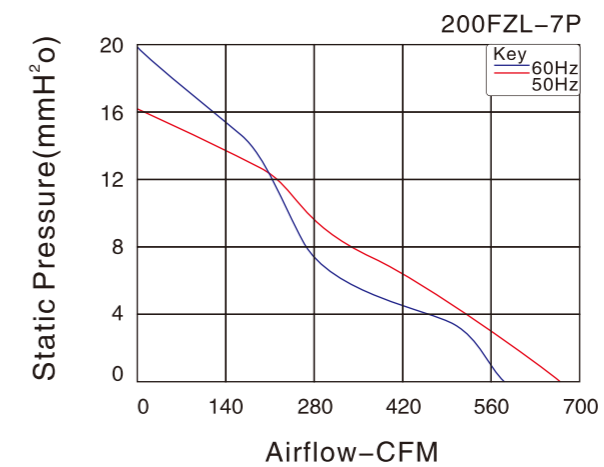

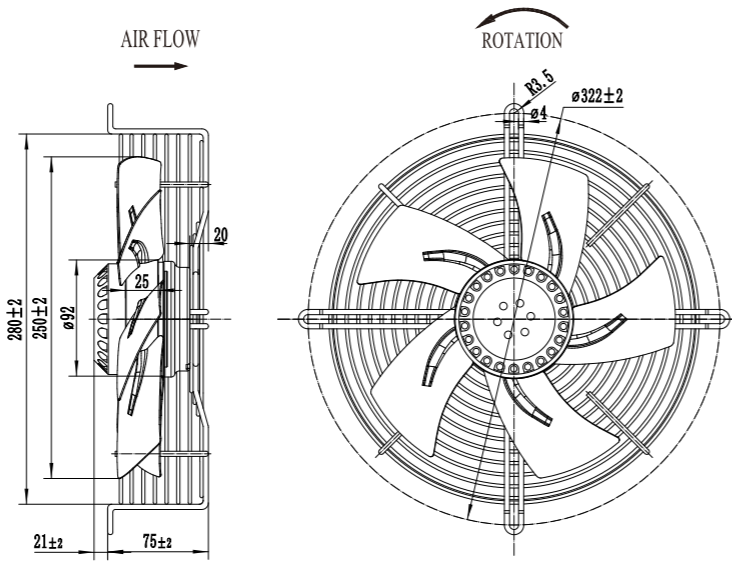

风量 Airflow: 494-870CFM  
重量 Weight: 2900g  
噪音 Noise: 58-73dB(A)  
风叶 Impeller Material: Metal  
外框 Frame: Metal guard  
端子 Terminals: 0.5mm  
引线 Lead Wire: Teflon22#UL 1332(Optional)  
马达 Motor: Capacitor-Run And External Rotor Induction Motor  
温度范围 Operating Temperature: -10°C~+65°C

产品型号 Model	轴承型式 Bearing System	电压 Voltage VAC	频率 Freq. Hz	电流 Current A	功率 Power W	转速 Speed RPM	噪音 Noise dB(A)	风量 Air Flow CFM	相数 Phase	电容 Capacitor $\mu$ F/VAC
250FZL2	Ball	200/240	50/60	0.2	40	1300/1500	58/63	494/565	1	4/500
250FZL3	Ball	380/420	50/60	0.1	40	1300/1500	58/63	494/565	3	/
250FZL4	Ball	380/420	50/60	0.12	40	1300/1500	58/63	494/565	1	2/500
250FZL6	Ball	200/240	50/60	0.5	100	2300/2700	68/73	776/870	1	4/500
250FZL7	Ball	380/420	50/60	0.2	100	2300/2700	68/73	776/870	3	/
250FZL8	Ball	380/420	50/60	0.35	100	2300/2700	68/73	776/870	1	2/500

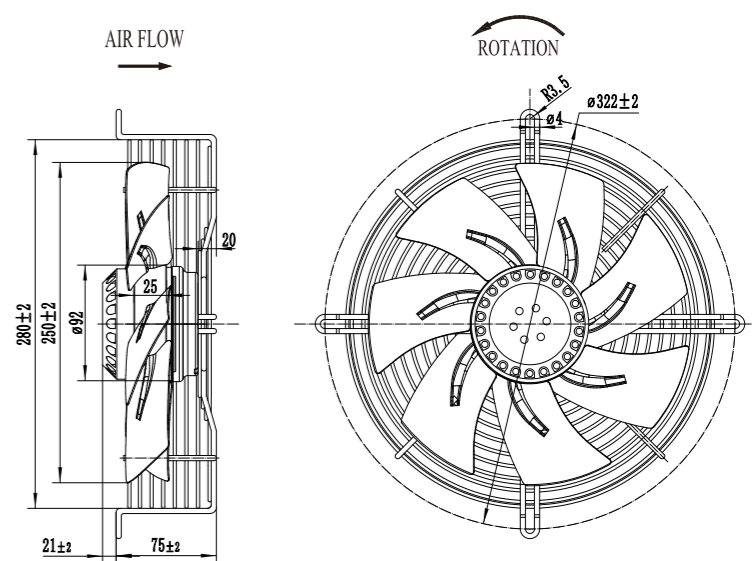
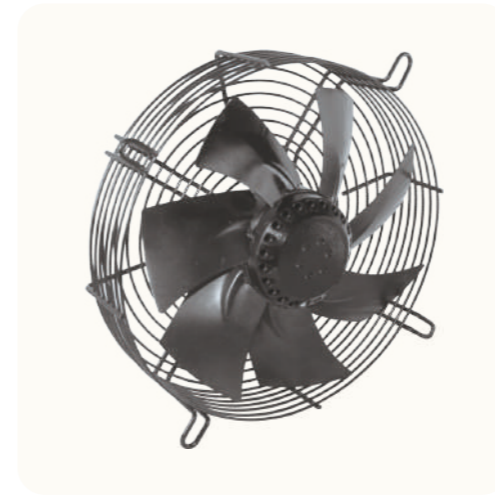
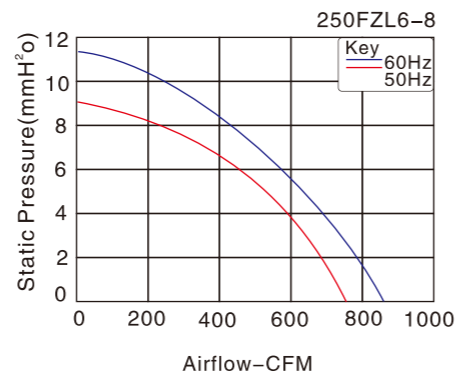
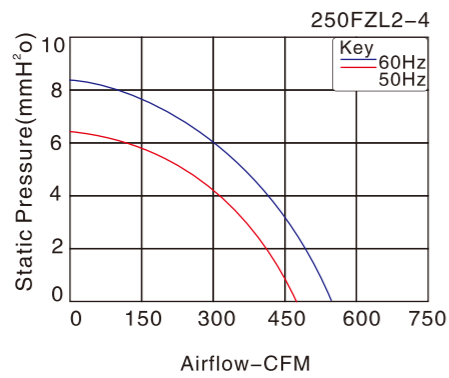

风量 Airflow: 530-1160CFM  
重量 Weight: 3000g  
噪音 Noise: 60-70dB(A)  
风叶 Impeller Material: Metal  
外框 Frame: Metal guard  
端子 Terminals: 0.5mm  
引线 Lead Wire: Teflon22#UL 1332(Optional)  
马达 Motor: Capacitor-Run And External Rotor Induction Motor  
温度范围 Operating Temperature: -10°C~+65°C

产品型号 Model	轴承型式 Bearing System	电压 Voltage VAC	频率 Freq. Hz	电流 Current A	功率 Power W	转速 Speed RPM	噪音 Noise dB(A)	风量 Air Flow CFM	相数 Phase	电容 Capacitor $\mu$ F/VAC
250FZY2-7P	Ball	220/240	50/60	0.3	50	1300/1500	60/65	530/600	1	4/500
250FZY3-7P	Ball	380/420	50/60	0.2	50	1300/1500	60/65	530/600	3	/
250FZY4-7P	Ball	380/420	50/60	0.35	50	1300/1500	60/65	530/600	1	2.2/500
250FZL1-7P	Ball	100/125	50/60	1.2/1.3	126/148	2500/2800	69/70	1098/1160	1	2.8/250
250FZL6-7P	Ball	200/240	50/60	0.58/0.63	126/148	2500/2800	69/70	1098/1160	1	4/500
250FZL7-7P	Ball	380/420	50/60	0.75/0.9	120/136	2500/2800	69/70	1098/1160	3	/
250FZL8-7P	Ball	380/420	50/60	0.24/0.25	120/136	2500/2800	69/70	1098/1160	1	2/500

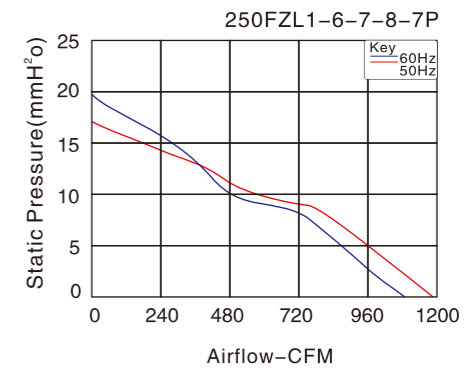
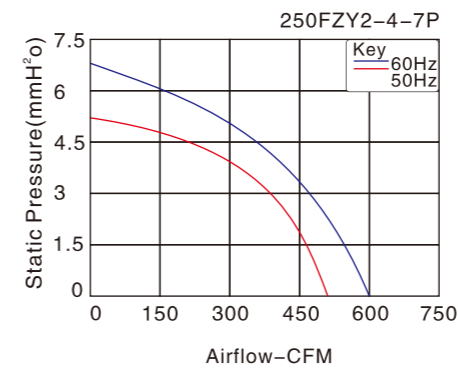

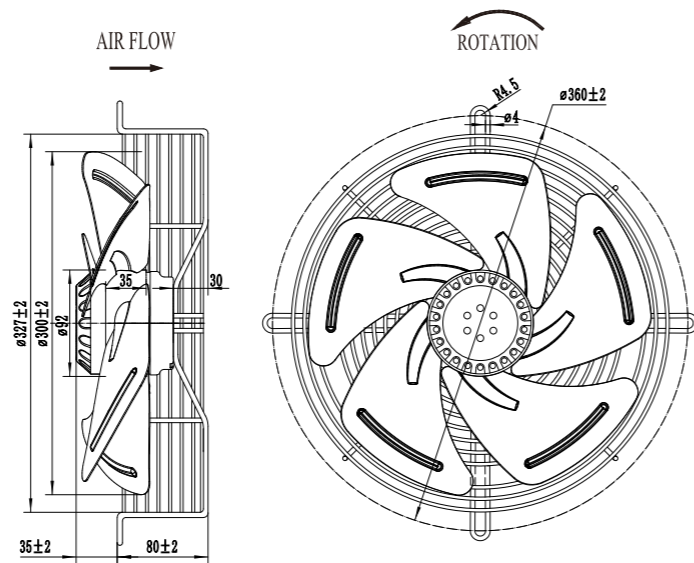

风量 Airflow: 847-931CFM  
重量 Weight: 3100g  
噪音 Noise: 65-68dB(A)  
风叶 Impeller Material: Metal  
外框 Frame: Metal guard  
端子 Terminals: 0.5mm  
引线 Lead Wire: Teflon18#UL 1332(Optional)  
马达 Motor: Capacitor-Run And External Rotor Induction Motor  
温度范围 Operating Temperature: -10°C~+65°C

产品型号 Model	轴承型式 Bearing System	电压 Voltage VAC	频率 Freq. Hz	电流 Current A	功率 Power W	转速 Speed RPM	噪音 Noise dB(A)	风量 Air Flow CFM	相数 Phase	电容 Capacitor μF/VAC
300FZL2	Ball	200/240	50/60	0.4	80	1300/1500	65/68	847/931	1	4/500
300FZL3	Ball	380/420	50/60	0.22	80	1300/1500	65/68	847/931	3	—
300FZL4	Ball	380/420	50/60	0.25	80	1300/1500	65/68	847/931	1	2.2/500

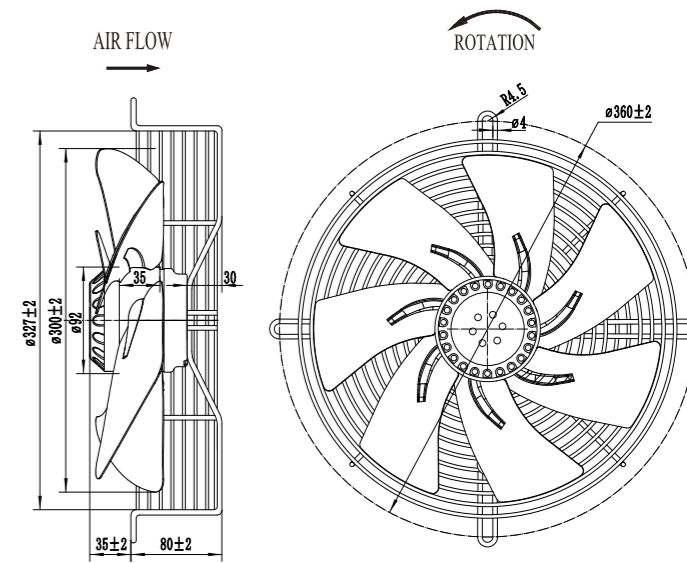
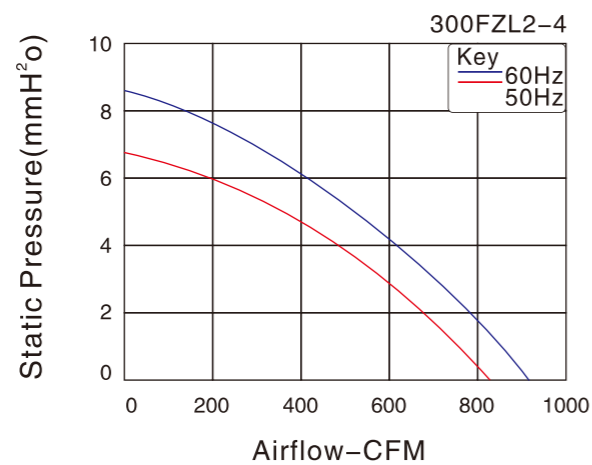

风量 Airflow: 920-1350CFM  
重量 Weight: 3150g  
噪音 Noise: 68-78dB(A)  
风叶 Impeller Material: Metal  
外框 Frame: Metal guard  
端子 Terminals: 0.5mm  
引线 Lead Wire: Teflon22#UL 1332(Optional)  
马达 Motor: Capacitor-Run And External Rotor Induction Motor  
温度范围 Operating Temperature: -10°C~+65°C

产品型号 Model	轴承型式 Bearing System	电压 Voltage VAC	频率 Freq. Hz	电流 Current A	功率 Power W	转速 Speed RPM	噪音 Noise dB(A)	风量 Air Flow CFM	相数 Phase	电容 Capacitor μF/VAC
300FZL2-7P	Ball	220/240	50/60	0.35	80	1300/1500	68/71	920/955	1	4/500
300FZL3-7P	Ball	380/420	50/60	0.3	80	1300/1500	68/71	920/955	3	—
300FZL4-7P	Ball	380/420	50/60	0.35	80	1300/1500	68/71	920/955	1	2.2/500
300FZL6-7P	Ball	220/240	50/60	0.5	150	2200/2500	73/78	1240/1350	1	4/500
300FZL7-7P	Ball	380/420	50/60	0.5	150	2200/2500	73/78	1240/1350	3	—
300FZL8-7P	Ball	220/240	50/60	0.5	150	2200/2500	73/78	1240/1350	1	2/500

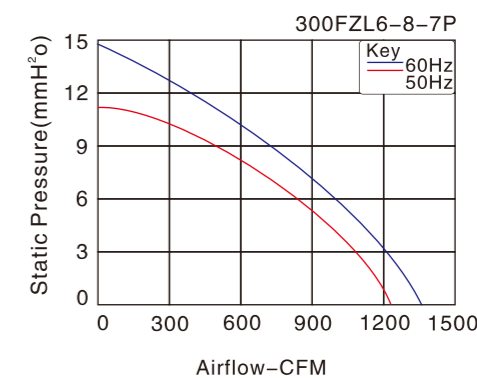
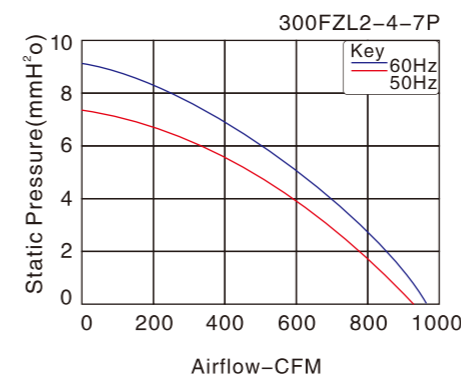

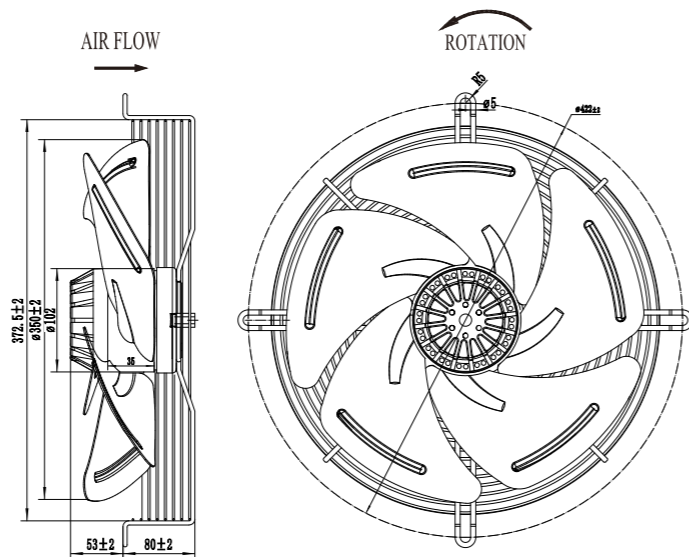

风量 Airflow: 1235~1836CFM  
重量 Weight: 4900g  
噪音 Noise: 56~65dB(A)  
风叶 Impeller Material: Metal  
外框 Frame: Metal guard  
端子 Terminals: 0.5mm  
引线 Lead Wire: Teflon18#UL 1332(Optional)  
马达 Motor: Capacitor-Run And External Rotor Induction Motor  
温度范围 Operating Temperature: -10°C~+65°C

产品型号 Model	轴承型式 Bearing System	电压 Voltage VAC	频率 Freq. Hz	电流 Current A	功率 Power W	转速 Speed RPM	噪音 Noise dB(A)	风量 Air Flow CFM	相数 Phase	电容 Capacitor $\mu$ F/VAC
350FZL2	Ball	200/240	50/60	0.48/0.56	100/124	1350/1550	62/65	1695/1836	1	5/500
350FZL3	Ball	380/420	50/60	0.35	150	1360/1500	62/65	1695/1836	3	—
350FZL4	Ball	380/420	50/60	0.4	150	1360/1500	62/65	1695/1836	1	2.2/500
350FZL6	Ball	200/240	50/60	0.42	91	950/1050	56/60	1235/1353	1	3/500
350FZL7	Ball	380/420	50/60	0.3	91	950/1050	56/60	1235/1353	3	—
350FZL8	Ball	380/420	50/60	0.35	91	950/1050	56/60	1235/1353	1	2/500

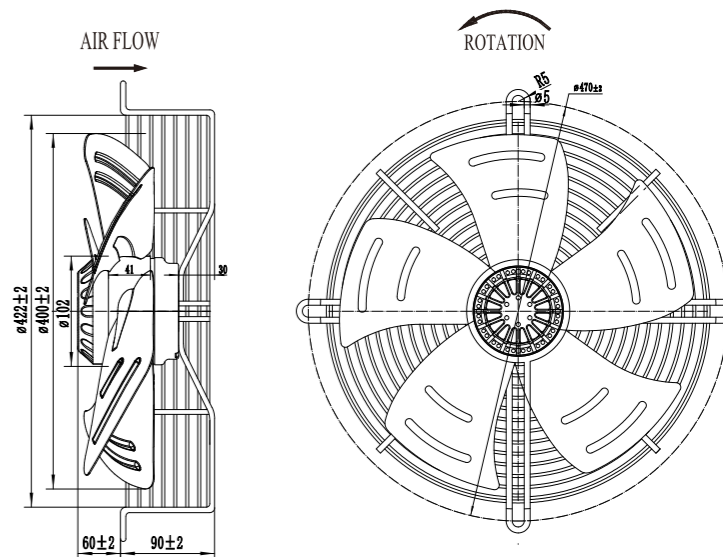
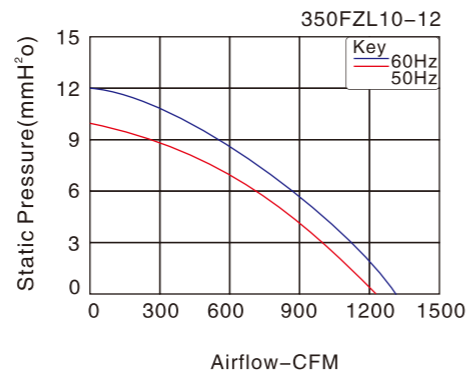
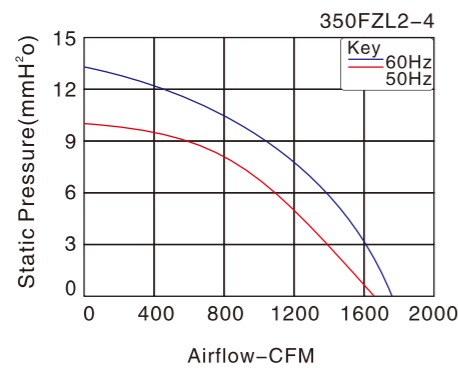

风量 Airflow: 1977~2589CFM  
重量 Weight: 5600g  
噪音 Noise: 58~70dB(A)  
风叶 Impeller Material: Metal  
外框 Frame: Metal guard  
端子 Terminals: 0.5mm  
引线 Lead Wire: Teflon18#UL 1332(Optional)  
马达 Motor: Capacitor-Run And External Rotor Induction Motor  
温度范围 Operating Temperature: -10°C~+65°C

产品型号 Model	轴承型式 Bearing System	电压 Voltage VAC	频率 Freq. Hz	电流 Current A	功率 Power W	转速 Speed RPM	噪音 Noise dB(A)	风量 Air Flow CFM	相数 Phase	电容 Capacitor $\mu$ F/VAC
400FZL2	Ball	200/240	50/60	0.8	180	1400/1560	68/70	2400/2589	1	6/500
400FZL3	Ball	380/420	50/60	0.4	180	1400/1560	68/70	2400/2589	3	—
400FZL4	Ball	380/420	50/60	0.45	180	1400/1560	68/70	2400/2589	1	4/500
400FZL10	Ball	200/240	50/60	0.5	112	950/1050	58/61	1977/2130	1	4/500
400FZL11	Ball	380/420	50/60	0.35	112	950/1050	58/61	1977/2130	3	—
400FZL12	Ball	380/420	50/60	0.4	112	950/1050	58/61	1977/2130	1	2.2/500

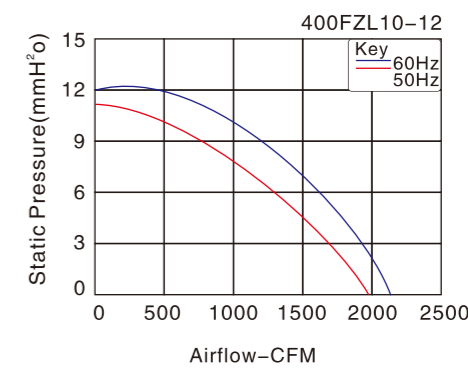
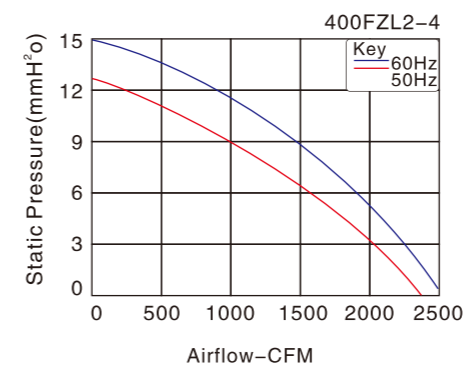

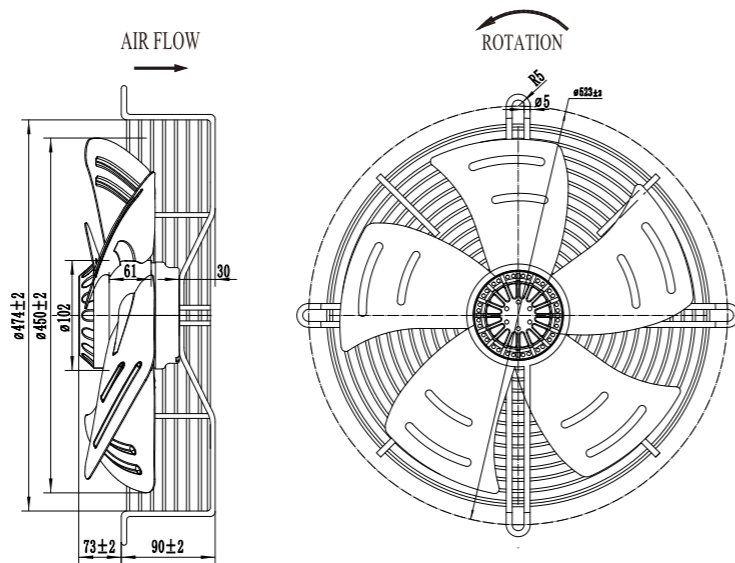

风量 Airflow: 2624~3413CFM  
重量 Weight: 7050g  
噪音 Noise: 59~73dB(A)  
风叶 Impeller Material: Metal  
外框 Frame: Metal guard  
端子 Terminals: 0.5mm  
引线 Lead Wire: Teflon18#UL 1332(Optional)  
马达 Motor: Capacitor-Run And External Rotor Induction Motor  
温度范围 Operating Temperature: -10°C~+65°C

产品型号 Model	轴承型式 Bearing System	电压 Voltage VAC	频率 Freq. Hz	电流 Current A	功率 Power W	转速 Speed RPM	噪音 Noise dB(A)	风量 Air Flow CFM	相数 Phase	电容 Capacitor $\mu$ F/VAC
450FZL2	Ball	200/240	50/60	1.15	250	1350/1450	70/73	3154/3413	1	8/500
450FZL3	Ball	380/420	50/60	0.52	250	1350/1450	70/73	3154/3413	3	—
450FZL4	Ball	380/420	50/60	0.6	250	1350/1450	70/73	3154/3413	1	4/500
450FZL10	Ball	200/240	50/60	0.71	160	920/1040	59/62	2624/2813	1	6/500
450FZL11	Ball	380/420	50/60	0.40	160	920/1040	59/62	2624/2813	3	—
450FZL12	Ball	380/420	50/60	0.45	160	920/1040	59/62	2624/2813	1	3/500

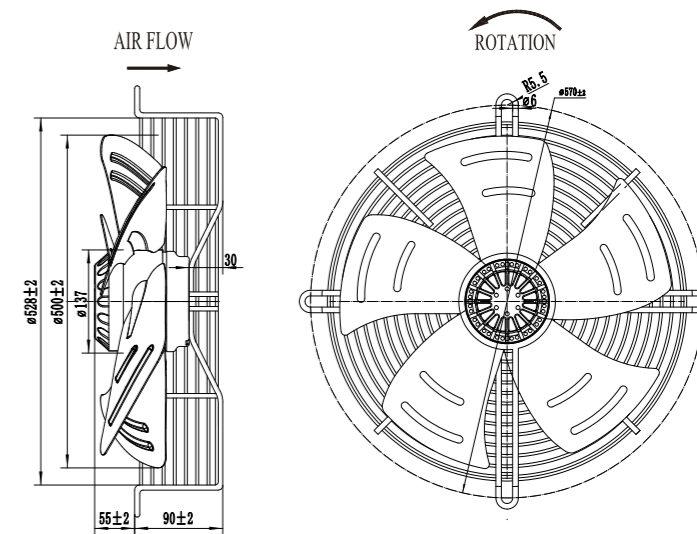
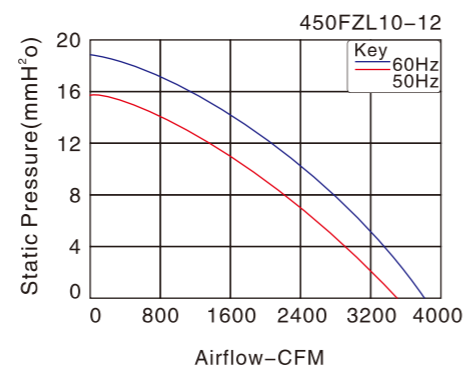
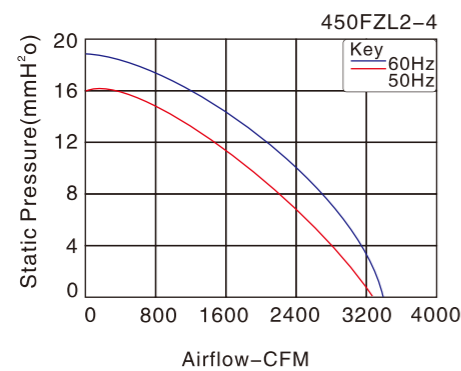

风量 Airflow: 3266~3895CFM  
重量 Weight: 9300g  
噪音 Noise: 65~73dB(A)  
风叶 Impeller Material: Metal  
外框 Frame: Metal guard  
端子 Terminals: 0.5mm  
引线 Lead Wire: Teflon18#UL 1332(Optional)  
马达 Motor: Capacitor-Run And External Rotor Induction Motor  
温度范围 Operating Temperature: -10°C~+65°C

产品型号 Model	轴承型式 Bearing System	电压 Voltage VAC	频率 Freq. Hz	电流 Current A	功率 Power W	转速 Speed RPM	噪音 Noise dB(A)	风量 Air Flow CFM	相数 Phase	电容 Capacitor $\mu$ F/VAC
500FZL2	Ball	200/240	50/60	1.8	480	1350/1470	70/73	3589/3895	1	10/500
500FZL3	Ball	380/420	50/60	0.9	480	1350/1470	70/73	3589/3895	3	—
500FZL4	Ball	380/420	50/60	1.2	480	1350/1470	70/73	3589/3895	1	5/500
500FZL10	Ball	200/240	50/60	1.2	240	925/1020	65/68	3266/3431	1	8/500
500FZL11	Ball	380/420	50/60	0.5	240	925/1020	65/68	3266/3431	3	—
500FZL12	Ball	380/420	50/60	0.65	240	925/1020	65/68	3266/3431	1	4/500

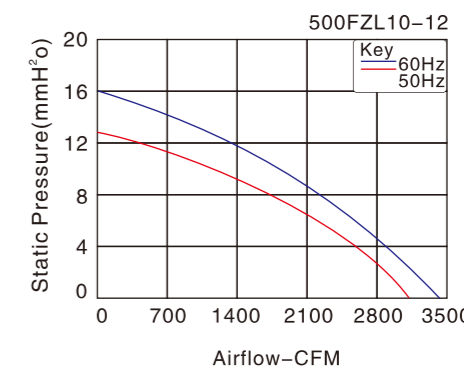
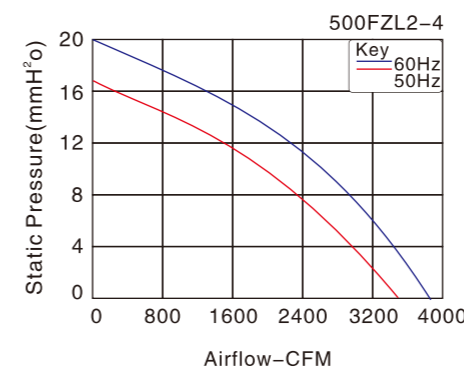

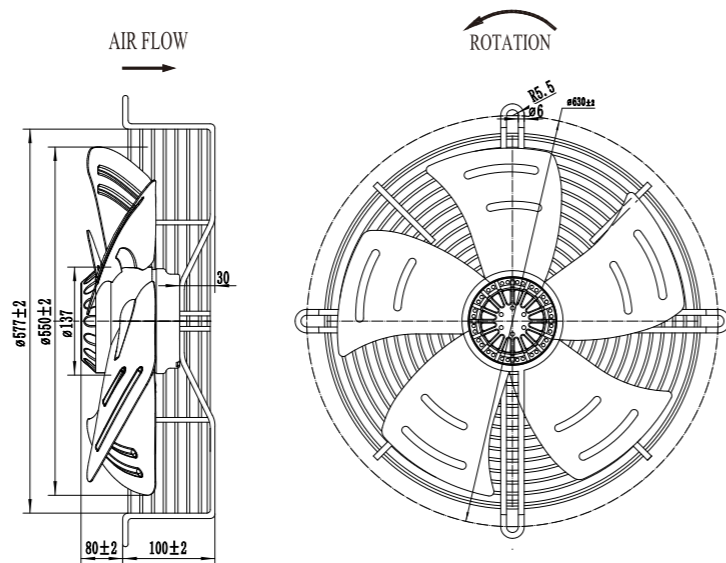

风量 Airflow: 3653-5237CFM  
重量 Weight: 11200g  
噪音 Noise: 68-73dB(A)  
风叶 Impeller Material: Metal  
外框 Frame: Metal guard  
端子 Terminals: 0.5mm  
引线 Lead Wire: Teflon18#UL 1332(Optional)  
马达 Motor: Capacitor-Run And External Rotor Induction Motor  
温度范围 Operating Temperature: -10°C~+65°C

产品型号 Model	轴承型式 Bearing System	电压 Voltage VAC	频率 Freq. Hz	电流 Current A	功率 Power W	转速 Speed RPM	噪音 Noise dB(A)	风量 Air Flow CFM	相数 Phase	电容 Capacitor $\mu$ F/VAC
550FZL2	Ball	200/240	50/60	2.1	500	1300/1420	70/73	4825/5237	1	10/500
550FZL3	Ball	380/420	50/60	0.95	500	1300/1420	70/73	4825/5237	3	—
550FZL4	Ball	380/420	50/60	1.5	500	1300/1420	70/73	4825/5237	1	5/500
550FZL10	Ball	200/240	50/60	1.2	280	900/980	68/71	3653/4013	1	8/500
550FZL11	Ball	380/420	50/60	0.72	280	900/980	68/71	3653/4013	3	—
550FZL12	Ball	380/420	50/60	0.85	280	900/980	68/71	3653/4013	1	4/500

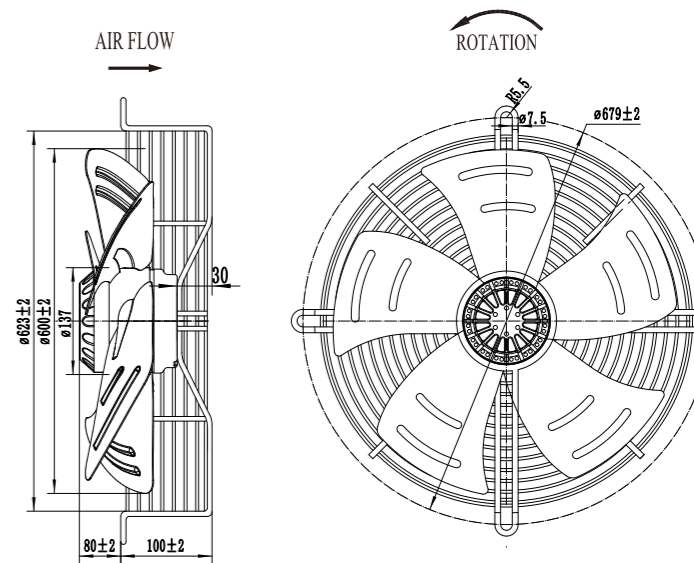
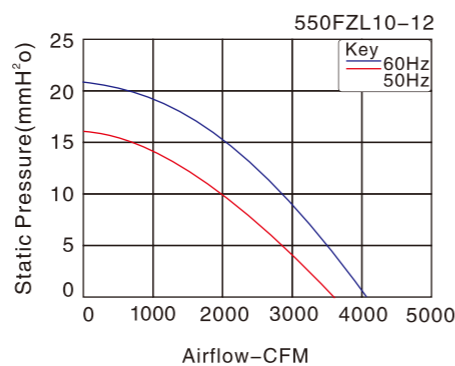
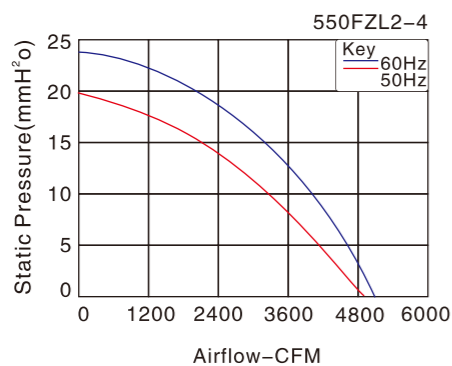

风量 Airflow: 4825-5437CFM  
重量 Weight: 14000g  
噪音 Noise: 70-80dB(A)  
风叶 Impeller Material: Metal  
外框 Frame: Metal guard  
端子 Terminals: 0.5mm  
引线 Lead Wire: Teflon18#UL 1332(Optional)  
马达 Motor: Capacitor-Run And External Rotor Induction Motor  
温度范围 Operating Temperature: -10°C~+65°C

产品型号 Model	轴承型式 Bearing System	电压 Voltage VAC	频率 Freq. Hz	电流 Current A	功率 Power W	转速 Speed RPM	噪音 Noise dB(A)	风量 Air Flow CFM	相数 Phase	电容 Capacitor $\mu$ F/VAC
600FZL10	Ball	200/240	50/60	2.4	520	900/950	70/78	4825/5237	1	10/500
600FZL11	Ball	380/420	50/60	1.4	520	900/950	70/78	4825/5237	3	—
600FZL4	Ball	380/420	50/60	1.6	820	1300/1400	73/80	4925/5437	3	—

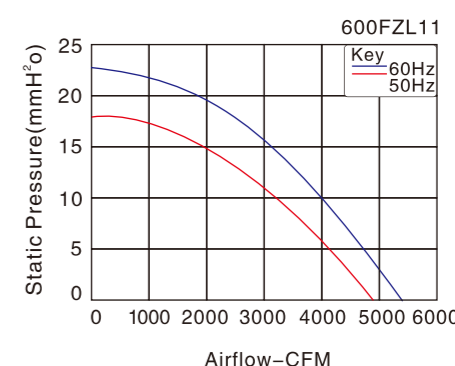
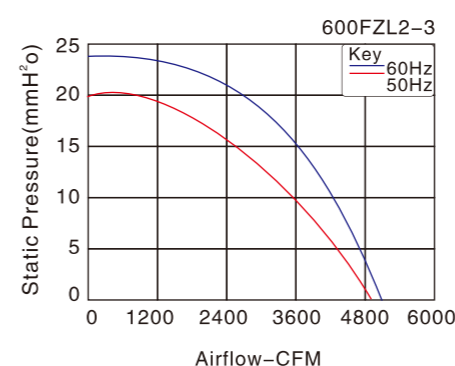

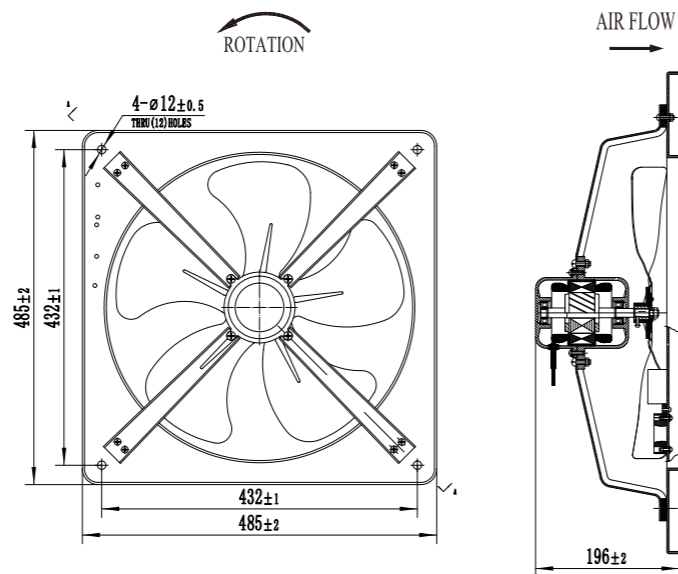

尺寸 Size: 485mm × 485mm × 196mm  
风量 Airflow: 1550–1725CFM  
重量 Weight: 4800g  
噪音 Noise: 70–73dB(A)  
风叶 Impeller Material: Aluminium  
外框 Frame: Metal  
端子 Terminals: 0.5mm  
引线 Lead Wire: Teflon22#UL 1332(Optional)  
马达 Motor: Capacitor-Run Induction Motor  
温度范围 Operating Temperature: -10°C~+65°C

产品型号 Model	轴承型式 Bearing System	电压 Voltage VAC	频率 Freq. Hz	电流 Current A	功率 Power W	转速 Speed RPM	噪音 Noise dB(A)	风量 Air Flow CFM	相数 Phase	电容 Capacitor μF/VAC
400FZD2	Ball	200/240	50/60	0.45/0.58	100/130	1400/1560	70/73	1550/1725	1	3.5/500
400FZD3	Ball	380/420	50/60	0.5	150	1400/1560	70/73	1550/1725	3	—
400FZD4	Ball	380/420	50/60	0.6/0.85	115/175	1400/1560	70/73	1550/1725	1	3/500

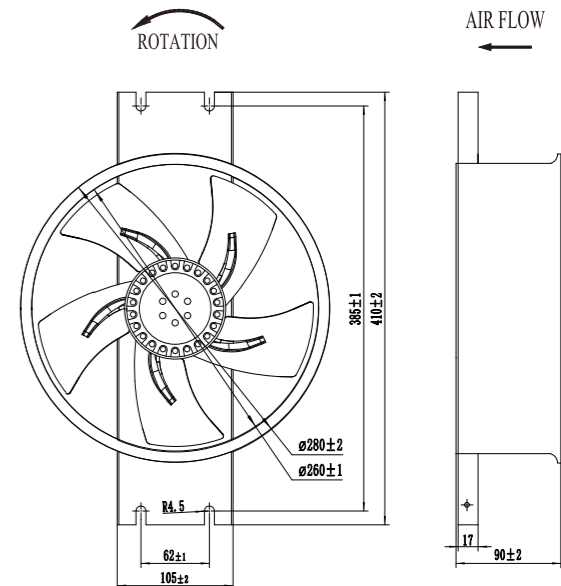
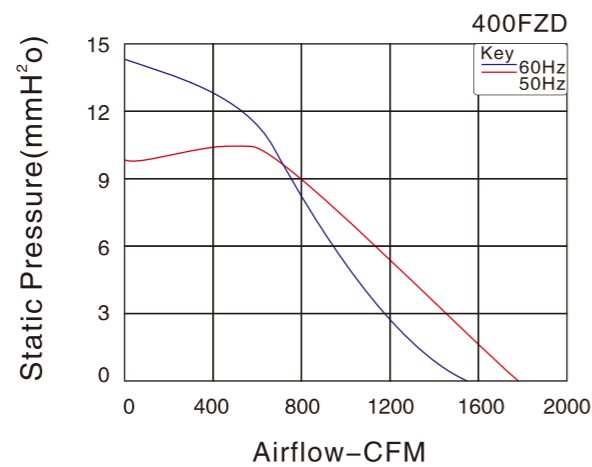

风量 Airflow: 494–870CFM  
重量 Weight: 3100g  
噪音 Noise: 58–73dB(A)  
风叶 Impeller Material: Metal  
外框 Frame: Metal  
端子 Terminals: 0.5mm  
引线 Lead Wire: Teflon22#UL 1332(Optional)  
马达 Motor: Capacitor-Run And External Rotor Induction Motor  
温度范围 Operating Temperature: -10°C~+65°C

产品型号 Model	轴承型式 Bearing System	电压 Voltage VAC	频率 Freq. Hz	电流 Current A	功率 Power W	转速 Speed RPM	噪音 Noise dB(A)	风量 Air Flow CFM	相数 Phase	电容 Capacitor μF/VAC
250FZY2-D	Ball	200/240	50/60	0.2	40	1300/1500	58/63	494/565	1	4/500
250FZY3-D	Ball	380/420	50/60	0.1	40	1300/1500	58/63	494/565	3	—
250FZY4-D	Ball	380/420	50/60	0.12	40	1300/1500	58/63	494/565	1	2/500
250FZY6-D	Ball	200/240	50/60	0.5	100	2300/2700	68/73	776/870	1	4/500
250FZY7-D	Ball	380/420	50/60	0.2	100	2300/2700	68/73	776/870	3	—
250FZY8-D	Ball	380/420	50/60	0.35	100	2300/2700	68/73	776/870	1	2/500

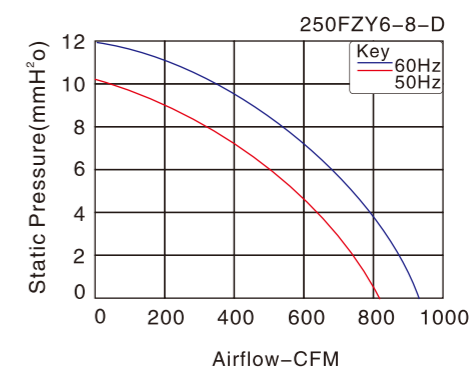
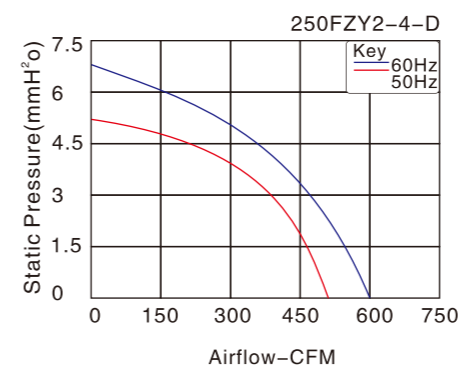

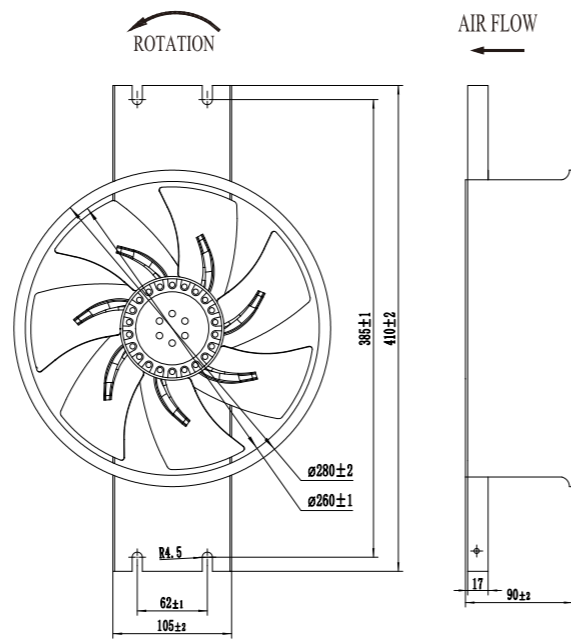

风量 Airflow: 530~1160CFM  
重量 Weight: 3150g  
噪音 Noise: 60~70dB(A)  
风叶 Impeller Material: Metal  
外框 Frame: Metal  
端子 Terminals: 0.5mm  
引线 Lead Wire: Teflon22#UL 1332(Optional)  
马达 Motor: Capacitor-Run And External Rotor Induction Motor  
温度范围 Operating Temperature: -10°C~+65°C

产品型号 Model	轴承型式 Bearing System	电压 Voltage VAC	频率 Freq. Hz	电流 Current A	功率 Power W	转速 Speed RPM	噪音 Noise dB(A)	风量 Air Flow CFM	相数 Phase	电容 Capacitor μF/VAC
250FZY2-D-7P	Ball	220/240	50/60	0.3	50	1300/1500	60/65	530/600	1	4/500
250FZY3-D-7P	Ball	380/420	50/60	0.2	50	1300/1500	60/65	530/600	3	—
250FZY4-D-7P	Ball	380/420	50/60	0.35	50	1300/1500	60/65	530/600	1	2.2/500
250FZY1-D-7P	Ball	100/125	50/60	1.2/1.3	126/148	2500/2800	69/70	1098/1160	1	2.8/250
250FZY6-D-7P	Ball	200/240	50/60	0.58/0.63	126/148	2500/2800	69/70	1098/1160	1	4/500
250FZY7-D-7P	Ball	380/420	50/60	0.75/0.9	120/136	2500/2800	69/70	1098/1160	3	—
250FZY8-D-7P	Ball	380/420	50/60	0.24/0.25	120/136	2500/2800	69/70	1098/1160	1	2/500

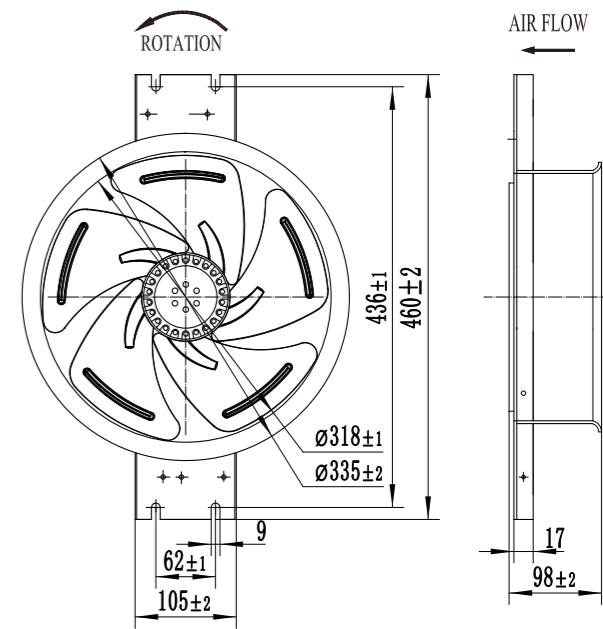
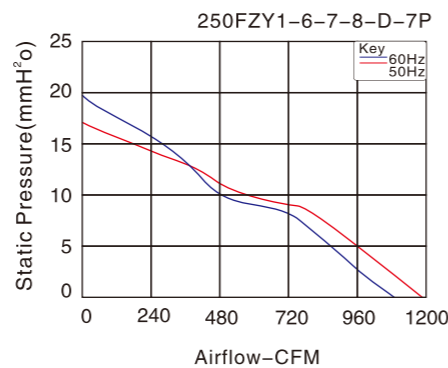
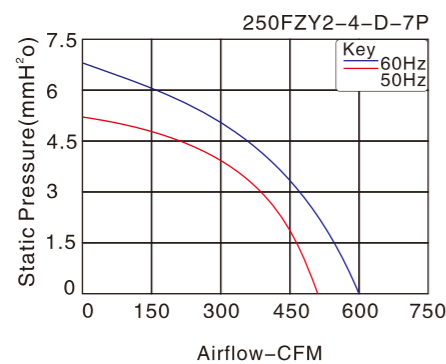

风量 Airflow: 847~931CFM  
重量 Weight: 3450g  
噪音 Noise: 65~68dB(A)  
风叶 Impeller Material: Metal  
外框 Frame: Metal  
端子 Terminals: 0.5mm  
引线 Lead Wire: Teflon22#UL 1332(Optional)  
马达 Motor: Capacitor-Run And External Rotor Induction Motor  
温度范围 Operating Temperature: -10°C~+65°C

产品型号 Model	轴承型式 Bearing System	电压 Voltage VAC	频率 Freq. Hz	电流 Current A	功率 Power W	转速 Speed RPM	噪音 Noise dB(A)	风量 Air Flow CFM	相数 Phase	电容 Capacitor μF/VAC
300FZY2-D	Ball	200/240	50/60	0.4	80	1300/1500	65/68	847/931	1	4/500
300FZY3-D	Ball	380/420	50/60	0.22	80	1300/1500	65/68	847/931	3	—
300FZY4-D	Ball	380/420	50/60	0.25	80	1300/1500	65/68	847/931	1	2.2/500

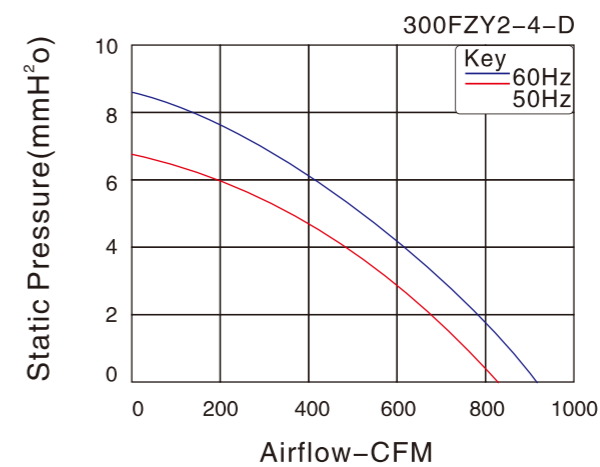

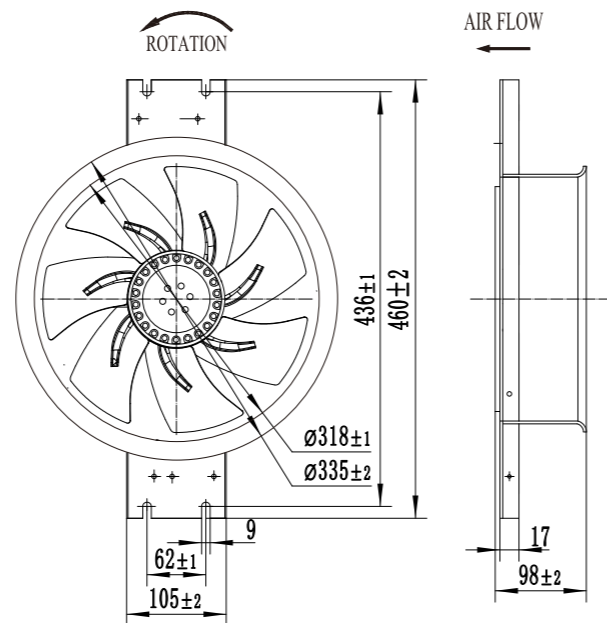

风量 Airflow: 920-1350CFM  
重量 Weight: 3550g  
噪音 Noise: 68-78dB(A)  
风叶 Impeller Material: Metal  
外框 Frame: Metal  
端子 Terminals: 0.5mm  
引线 Lead Wire: Teflon22#UL 1332(Optional)  
马达 Motor: Capacitor-Run And External Rotor Induction Motor  
温度范围 Operating Temperature:  $-10^{\circ}\text{C} \sim +65^{\circ}\text{C}$

产品型号 Model	轴承型式 Bearing System	电压 Voltage VAC	频率 Freq. Hz	电流 Current A	功率 Power W	转速 Speed RPM	噪音 Noise dB(A)	风量 Air Flow CFM	相数 Phase	电容 Capacitor $\mu\text{F}/\text{VAC}$
300FZY2-D-7P	Ball	200/240	50/60	0.35	80	1300/1500	68/71	920/955	1	4/500
300FZY3-D-7P	Ball	380/420	50/60	0.3	80	1300/1500	68/71	920/955	3	—
300FZY4-D-7P	Ball	380/420	50/60	0.35	80	1300/1500	68/71	920/955	1	2.2/500
300FZY6-D-7P	Ball	200/240	50/60	0.5	150	2200/2500	73/78	1240/1350	1	4/500
300FZY7-D-7P	Ball	380/420	50/60	0.5	150	2200/2500	73/78	1240/1350	3	—
300FZY8-D-7P	Ball	220/240	50/60	0.5	150	2200/2500	73/78	1240/1350	1	2.2/500

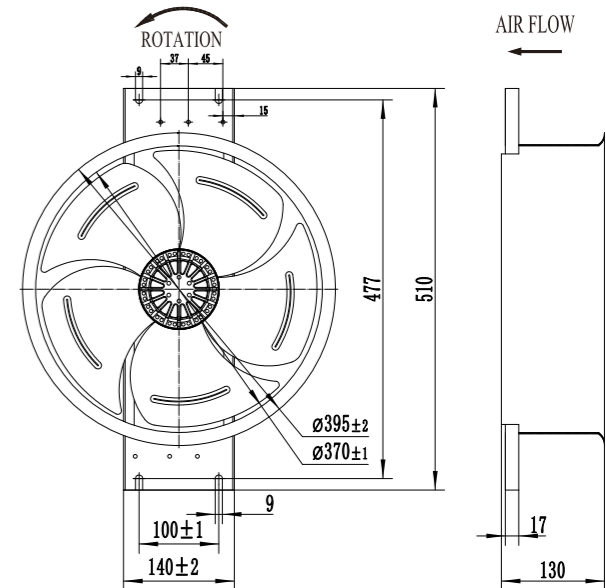
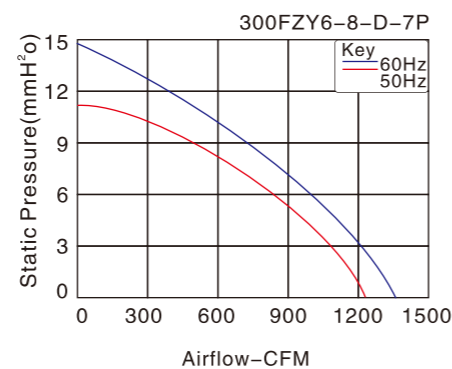
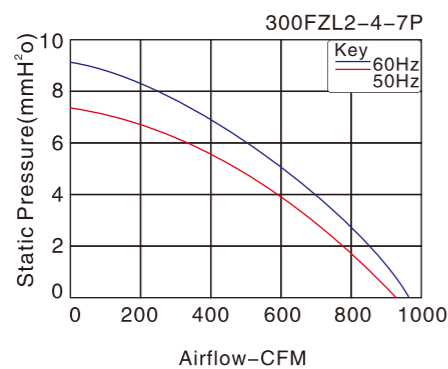

风量 Airflow: 1235-1836CFM  
重量 Weight: 5950g  
噪音 Noise: 56-65dB(A)  
风叶 Impeller Material: Metal  
外框 Frame: Metal  
端子 Terminals: 0.5mm  
引线 Lead Wire: Teflon18#UL 1332(Optional)  
马达 Motor: Capacitor-Run And External Rotor Induction Motor  
温度范围 Operating Temperature:  $-10^{\circ}\text{C} \sim +65^{\circ}\text{C}$

产品型号 Model	轴承型式 Bearing System	电压 Voltage VAC	频率 Freq. Hz	电流 Current A	功率 Power W	转速 Speed RPM	噪音 Noise dB(A)	风量 Air Flow CFM	相数 Phase	电容 Capacitor $\mu\text{F}/\text{VAC}$
350FZY2-D	Ball	200/240	50/60	0.48/0.56	100/124	1360/1550	62/65	1659/1836	1	5/500
350FZY3-D	Ball	380/420	50/60	0.35	150	1360/1550	62/65	1695/1836	3	—
350FZY4-D	Ball	380/420	50/60	0.4	150	1360/1550	62/65	1695/1836	1	2.2/500
350FZY10-D	Ball	200/240	50/60	0.42	91	950/1050	56/60	1235/1353	3	—
350FZY11-D	Ball	380/420	50/60	0.3	91	950/1050	56/60	1235/1353	3	—
350FZY12-D	Ball	380/420	50/60	0.35	91	950/1050	56/60	1235/1353	1	2/500

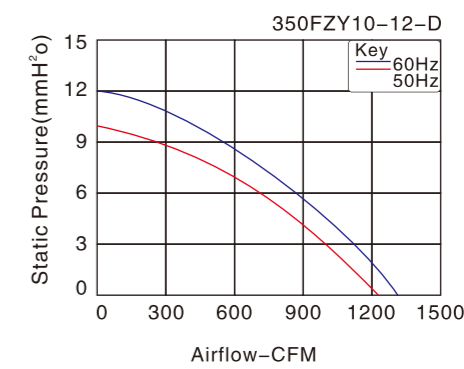
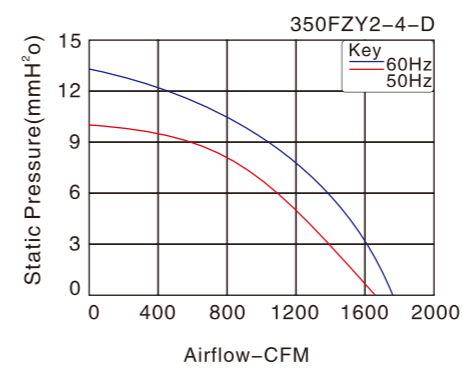

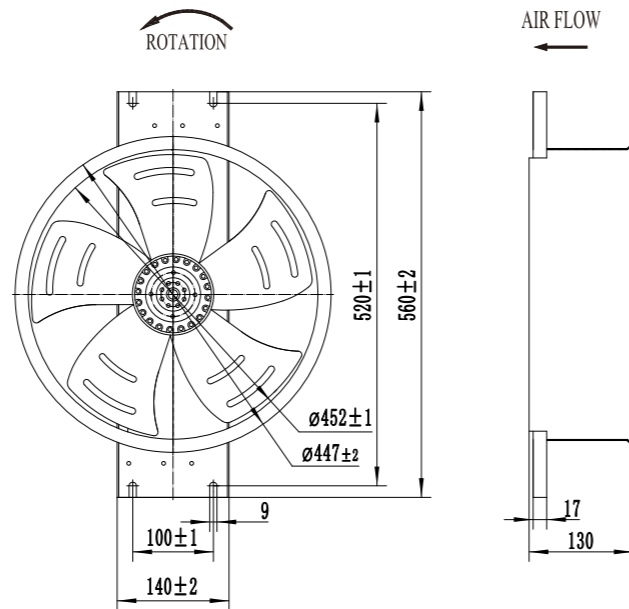

风量 Airflow: 1977~2589CFM  
重量 Weight: 6800g  
噪音 Noise: 58~70dB(A)  
风叶 Impeller Material: Metal  
外框 Frame: Metal  
端子 Terminals: 0.5mm  
引线 Lead Wire: Teflon18#UL 1332(Optional)  
马达 Motor: Capacitor-Run And External Rotor Induction Motor  
温度范围 Operating Temperature: -10°C~+65°C

产品型号 Model	轴承型式 Bearing System	电压 Voltage VAC	频率 Freq. Hz	电流 Current A	功率 Power W	转速 Speed RPM	噪音 Noise dB(A)	风量 Air Flow CFM	相数 Phase	电容 Capacitor μF/VAC
400FZY2-D	Ball	200/240	50/60	0.8	180	1400/1560	68/70	2400/2589	1	6/500
400FZY3-D	Ball	380/420	50/60	0.4	180	1400/1560	68/70	2400/2589	3	—
400FZY4-D	Ball	380/420	50/60	0.45	180	1400/1560	68/70	2400/2589	1	3/500
400FZY10-D	Ball	200/240	50/60	0.5	112	950/1050	58/61	1977/2130	1	4/500
400FZY11-D	Ball	380/420	50/60	0.35	112	95/1050	58/61	1977/2130	3	—
400FZY12-D	Ball	380/420	50/60	0.4	112	950/1050	58/61	1977/2130	1	2.2/500

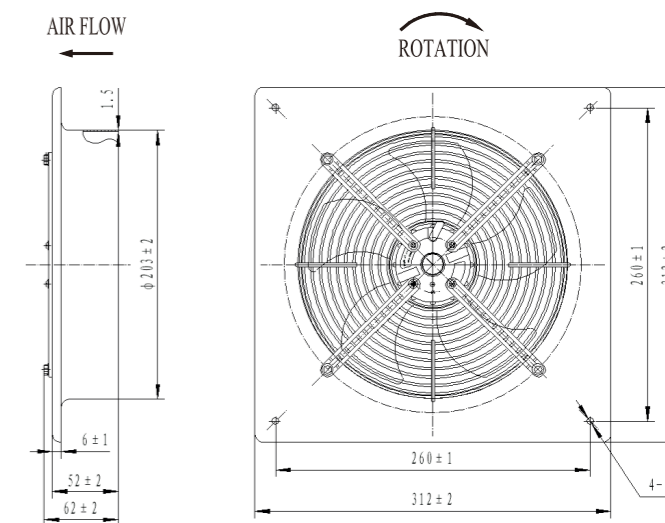
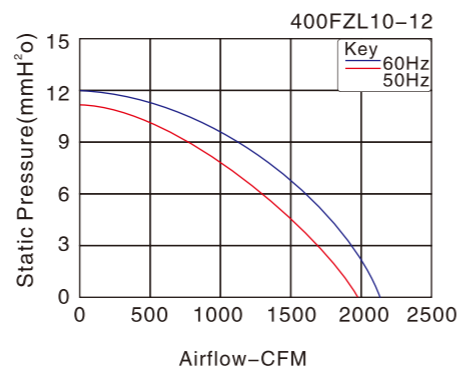
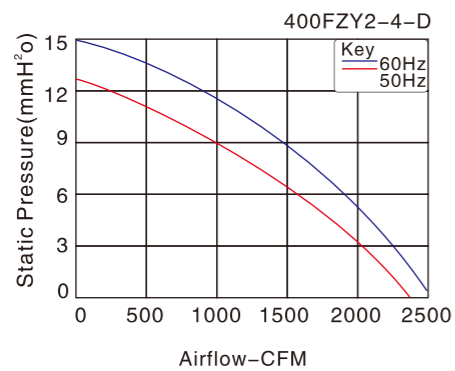

尺寸 Size: 312mm × 312mm × 62mm  
风量 Airflow: 605~642CFM  
噪音 Noise: 65~68dB(A)  
风叶 Impeller Material: Metal  
马达 Motor: Capacitor-Run And External Rotor Induction Motor  
引线 Lead Wire: Teflon22#UL 1332(Optional)  
温度范围 Operating Temperature: -10°C~+65°C  
防护等级 Type of protection: IP44  
绝缘等级 Insulation class: "F"

产品型号 Model	轴承型式 Bearing System	电压 Voltage VAC	频率 Freq. Hz	电流 Current A	功率 Power W	转速 Speed RPM	噪音 Noise dB(A)	风量 Air Flow CFM	相数 Phase	电容 Capacitor μF/VAC
200FZL5-D	Ball	100/125	50/60	0.68/0.65	67/77	2550/2850	65/68	605/642	1	4/500
200FZL6-D	Ball	200/240	50/60	0.35/0.28	60/80	2550/2850	65/68	605/642	1	2.2/500
200FZL7-D	Ball	380/420	50/60	0.45/0.4	62/70	2550/2850	65/68	605/642	3	—
200FZL8-D	Ball	380/420	50/60	0.16/0.19	62/74	2550/2850	65/68	605/642	1	1/500

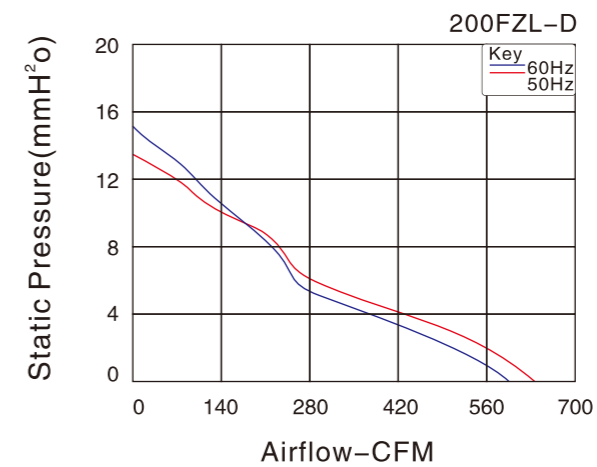

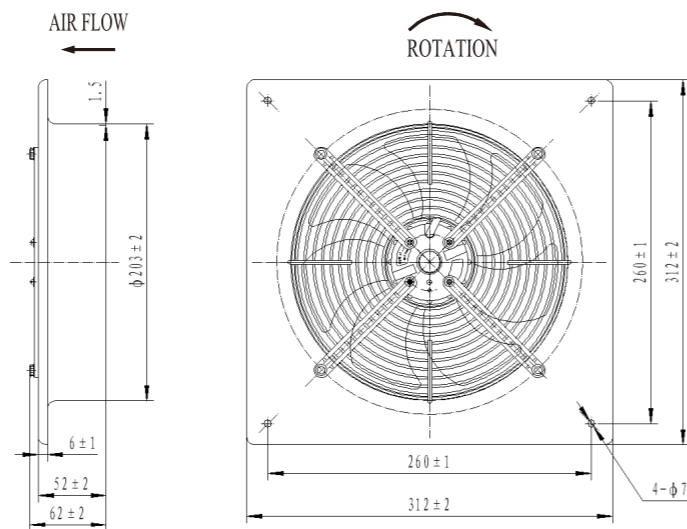

尺寸 Size: 312mm × 312mm × 62mm  
风量 Airflow: 597-661CFM  
噪音 Noise: 59-61dB(A)  
风叶 Impeller Material: Metal  
马达 Motor: Capacitor-Run And External Rotor Induction Motor  
引线 Lead Wire: Teflon22#UL 1332(Optional)  
温度范围 Operating Temperature: -10°C~+65°C  
防护等级 Type of protection: IP44  
绝缘等级 Insulation class: "F"

产品型号 Model	轴承型式 Bearing System	电压 Voltage VAC	频率 Freq. Hz	电流 Current A	功率 Power W	转速 Speed RPM	噪音 Noise dB(A)	风量 Air Flow CFM	相数 Phase	电容 Capacitor μF/VAC
200FZL5-7P-D	Ball	100/125	50/60	0.68/0.65	60/72	2700/3100	59/61	597/661	1	4/500
200FZL6-7P-D	Ball	200/240	50/60	0.25/0.33	54/71	2700/3100	59/61	597/661	1	2.2/500
200FZL7-7P-D	Ball	380/420	50/60	0.25	50	2700/3100	59/61	597/661	3	—
200FZL8-7P-D	Ball	380/420	50/60	0.23/0.2	68/76	2700/3100	59/61	597/661	1	1/500

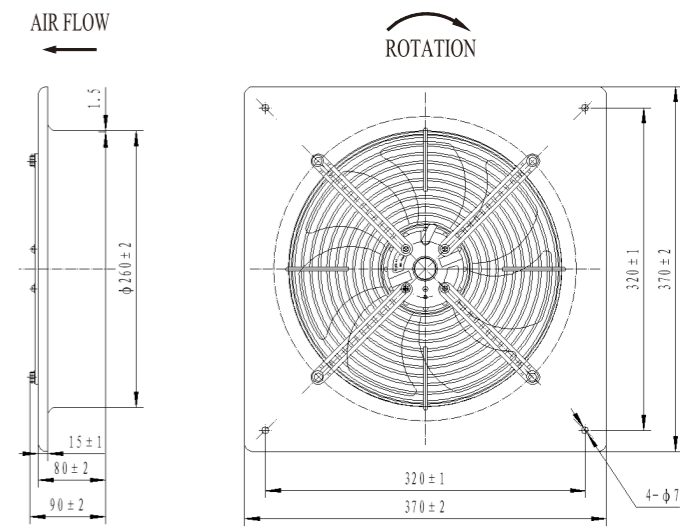
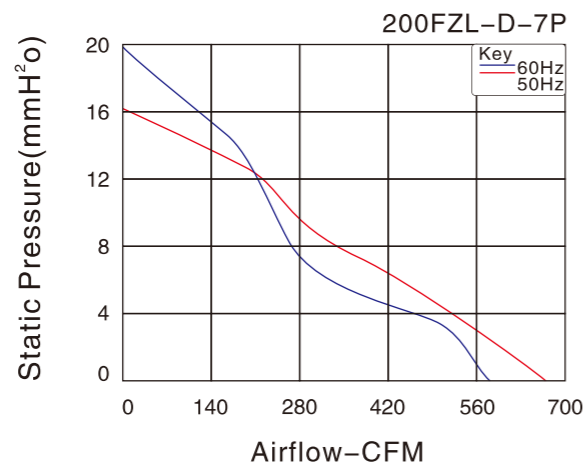

尺寸 Size: 370mm × 370mm × 90mm  
风量 Airflow: 494-870CFM  
噪音 Noise: 58-73dB(A)  
风叶 Impeller Material: Metal  
马达 Motor: Capacitor-Run And External Rotor Induction Motor  
引线 Lead Wire: Teflon22#UL 1332(Optional)  
温度范围 Operating Temperature: -10°C~+65°C  
防护等级 Type of protection: IP44  
绝缘等级 Insulation class: "F"

产品型号 Model	轴承型式 Bearing System	电压 Voltage VAC	频率 Freq. Hz	电流 Current A	功率 Power W	转速 Speed RPM	噪音 Noise dB(A)	风量 Air Flow CFM	相数 Phase	电容 Capacitor μF/VAC
250FZL2-D	Ball	220/240	50/60	0.2	40	1300/1500	58/63	494/565	1	4/500
250FZL3-D	Ball	380/420	50/60	0.1	40	1300/1500	58/63	494/565	3	—
250FZL4-D	Ball	380/420	50/60	0.12	40	1300/1500	58/63	494/565	1	2/500
250FZL6-D	Ball	200/240	50/60	0.5	100	2300/2700	68/73	776/870	1	4/500
250FZL7-D	Ball	380/420	50/60	0.2	100	2300/2700	68/73	776/870	3	—
250FZL8-D	Ball	380/420	50/60	0.35	100	2300/2700	68/73	776/870	1	2/500

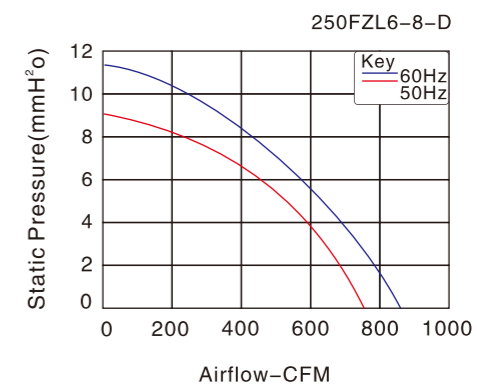
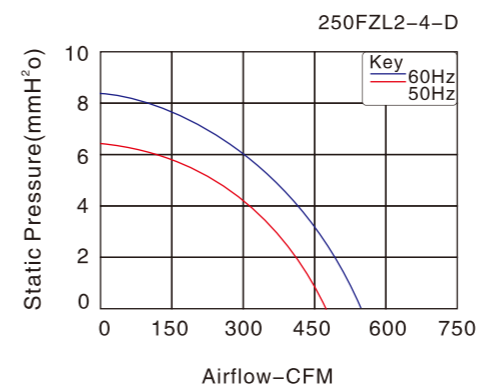

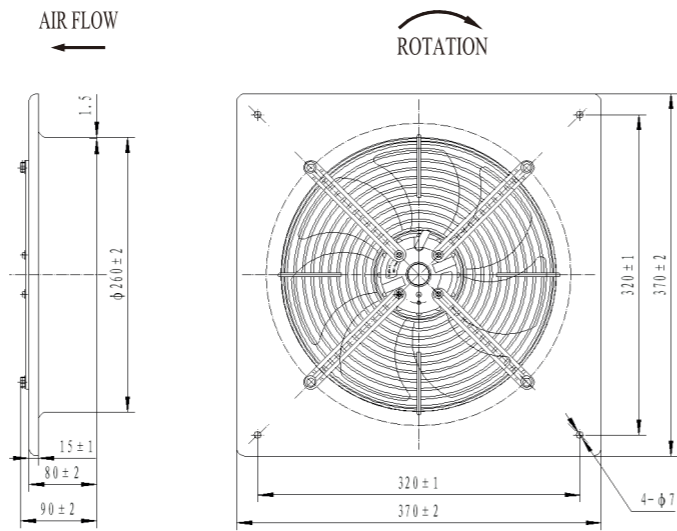

尺寸 Size: 370mm × 370mm × 90mm  
风量 Airflow: 530-1160CFM  
噪音 Noise: 60-70dB(A)  
风叶 Impeller Material: Metal  
马达 Motor: Capacitor-Run And External Rotor Induction Motor  
引线 Lead Wire: Teflon22#UL 1332(Optional)  
温度范围 Operating Temperature: -10°C~+65°C  
防护等级 Type of protection: IP44  
绝缘等级 Insulation class: "F"

产品型号 Model	轴承型式 Bearing System	电压 Voltage VAC	频率 Freq. Hz	电流 Current A	功率 Power W	转速 Speed RPM	噪音 Noise dB(A)	风量 Air Flow CFM	相数 Phase	电容 Capacitor μF/VAC
250FZL2-7P-D	Ball	220/240	50/60	0.3	50	1300/1500	60/65	530/600	1	4/500
250FZL3-7P-D	Ball	380/420	50/60	0.2	50	1300/1500	60/65	530/600	3	—
250FZL4-7P-D	Ball	380/420	50/60	0.35	50	1300/1500	60/65	530/600	1	2.2/500
250FZL1-7P-D	Ball	100/125	50/60	1.2/1.3	126/148	2500/2800	69/70	1098/1160	1	2.8/500
250FZL6-7P-D	Ball	200/240	50/60	0.58/0.63	126/148	2500/2800	69/70	1098/1160	1	4/500
250FZL7-7P-D	Ball	380/420	50/60	0.75/0.9	120/136	2500/2800	69/70	1098/1160	3	—
250FZL8-7P-D	Ball	380/420	50/60	0.24/0.25	120/136	2500/2800	69/70	1098/1160	1	2/500

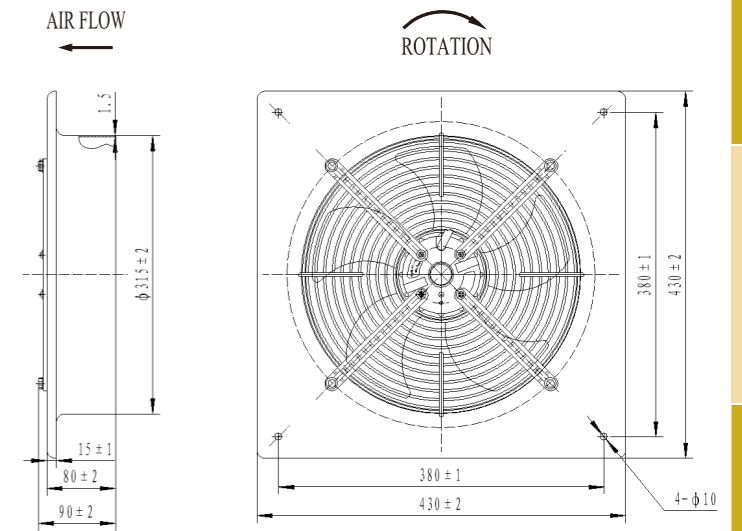
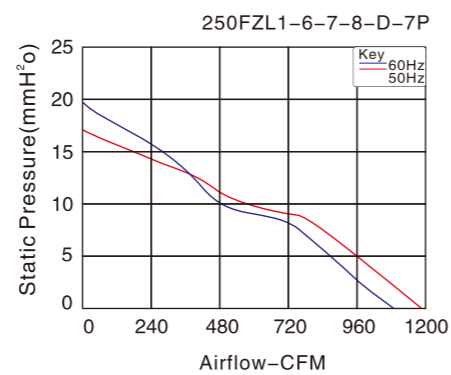
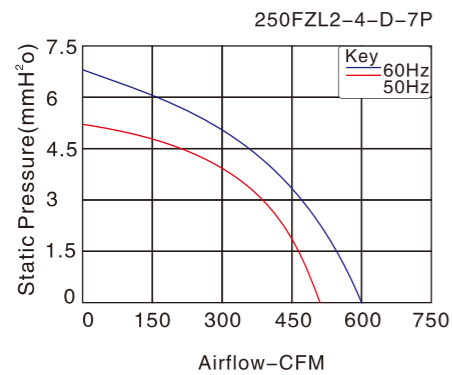

尺寸 Size: 430mm × 430mm × 90mm  
风量 Airflow: 847-931CFM  
噪音 Noise: 65-68dB(A)  
风叶 Impeller Material: Metal  
马达 Motor: Capacitor-Run And External Rotor Induction Motor  
引线 Lead Wire: Teflon22#UL 1332(Optional)  
温度范围 Operating Temperature: -10°C~+65°C  
防护等级 Type of protection: IP44  
绝缘等级 Insulation class: "F"

产品型号 Model	轴承型式 Bearing System	电压 Voltage VAC	频率 Freq. Hz	电流 Current A	功率 Power W	转速 Speed RPM	噪音 Noise dB(A)	风量 Air Flow CFM	相数 Phase	电容 Capacitor μF/VAC
300FZL2-D	Ball	200/240	50/60	0.4	80	1300/1500	65/68	847/931	1	4/500
300FZL3-D	Ball	380/420	50/60	0.22	80	1300/1500	65/68	847/931	3	—
300FZL4-D	Ball	380/420	50/60	0.25	80	1300/1500	65/68	847/931	1	2.2/500

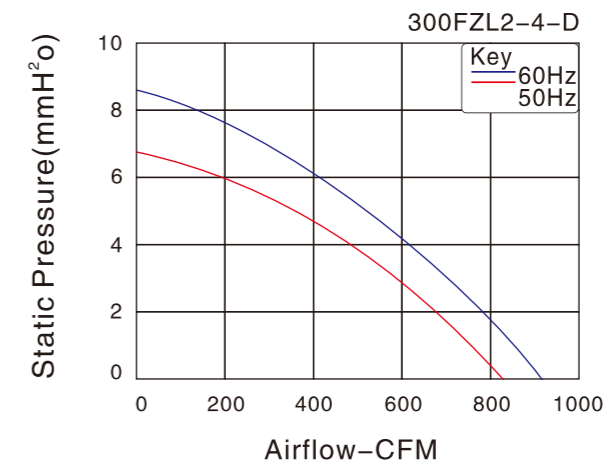

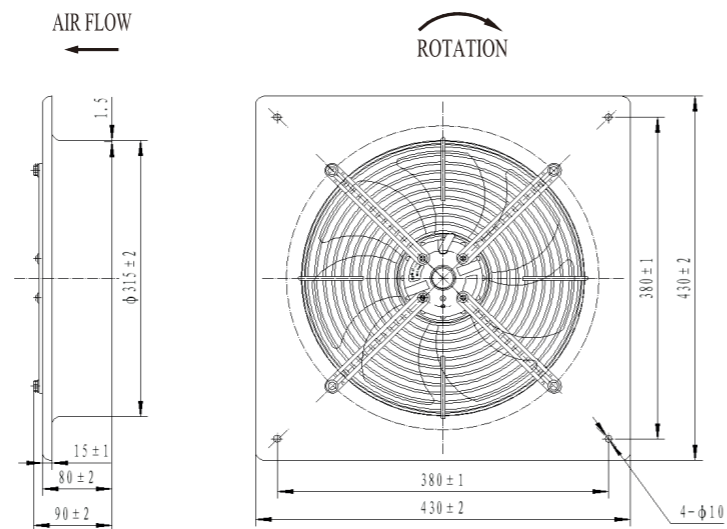

尺寸 Size: 430mm × 430mm × 90mm  
风量 Airflow: 920–1350CFM  
噪音 Noise: 68–78dB(A)  
风叶 Impeller Material: Metal  
马达 Motor: Capacitor-Run And External Rotor Induction Motor  
引线 Lead Wire: Teflon22#UL 1332(Optional)  
温度范围 Operating Temperature: -10℃~+65℃  
防护等级 Type of protection: IP44  
绝缘等级 Insulation class: "F"

产品型号 Model	轴承型式 Bearing System	电压 Voltage VAC	频率 Freq. Hz	电流 Current A	功率 Power W	转速 Speed RPM	噪音 Noise dB(A)	风量 Air Flow CFM	相数 Phase	电容 Capacitor μF/VAC
300FZL2-7P-D	Ball	220/240	50/60	0.35	80	1300/1500	68/71	920/955	1	4/500
300FZL3-7P-D	Ball	380/420	50/60	0.3	80	1300/1500	68/71	920/955	3	—
300FZL4-7P-D	Ball	380/420	50/60	0.35	80	1300/1500	68/71	920/955	1	2.2/500
300FZL6-7P-D	Ball	220/240	50/60	0.5	150	2200/2500	73/78	1240/1350	1	4/500
300FZL7-7P-D	Ball	380/420	50/60	0.5	150	2200/2500	73/78	1240/1350	3	—
300FZL8-7P-D	Ball	220/240	50/60	0.5	150	2200/2500	73/78	1240/1350	1	2.2/500

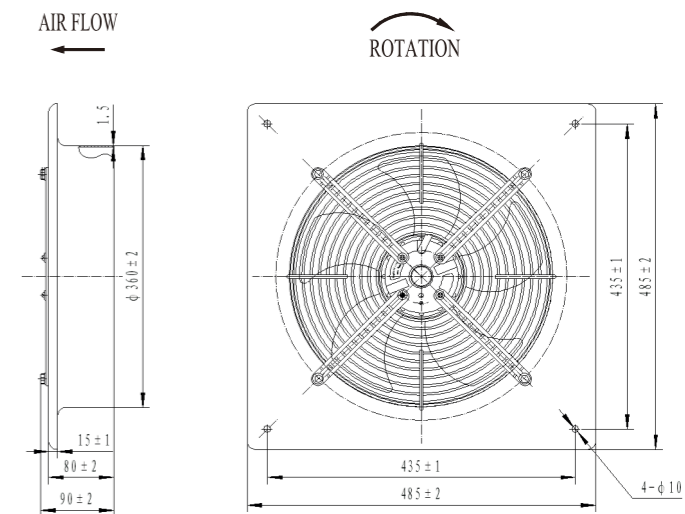
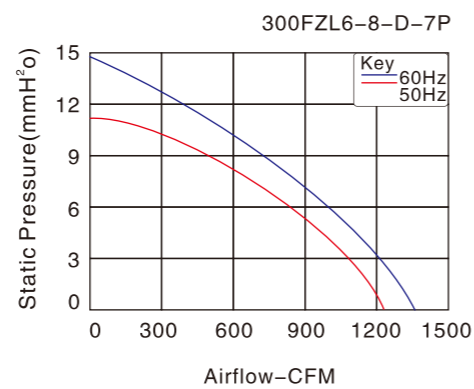
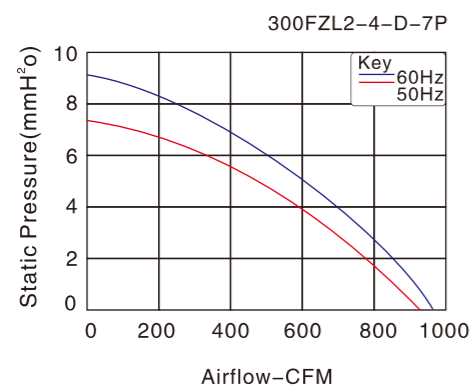

尺寸 Size: 485mm × 485mm × 90mm  
风量 Airflow: 1235–1836CFM  
噪音 Noise: 56–65dB(A)  
风叶 Impeller Material: Metal  
马达 Motor: Capacitor-Run And External Rotor Induction Motor  
引线 Lead Wire: Teflon18#UL 1332(Optional)  
温度范围 Operating Temperature: -10℃~+65℃  
防护等级 Type of protection: IP44  
绝缘等级 Insulation class: "F"

产品型号 Model	轴承型式 Bearing System	电压 Voltage VAC	频率 Freq. Hz	电流 Current A	功率 Power W	转速 Speed RPM	噪音 Noise dB(A)	风量 Air Flow CFM	相数 Phase	电容 Capacitor μF/VAC
350FZL2-D	Ball	200/240	50/60	0.48/0.56	100/124	1360/1550	62/65	1695/1836	1	5/500
350FZL3-D	Ball	380/420	50/60	0.35	150	1360/1550	62/65	1695/1836	3	—
350FZL4-D	Ball	380/420	50/60	0.4	150	1360/1550	62/65	1695/1836	1	2.2/500
350FZL6-D	Ball	200/240	50/60	0.42	91	950/1050	56/60	1235/1353	1	3/500
350FZL7-D	Ball	380/420	50/60	0.3	91	950/1050	56/60	1235/1353	3	—
350FZL8-D	Ball	380/420	50/60	0.35	91	950/1050	56/60	1235/1353	1	2/500

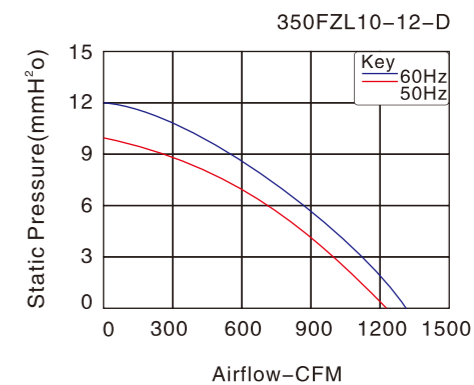
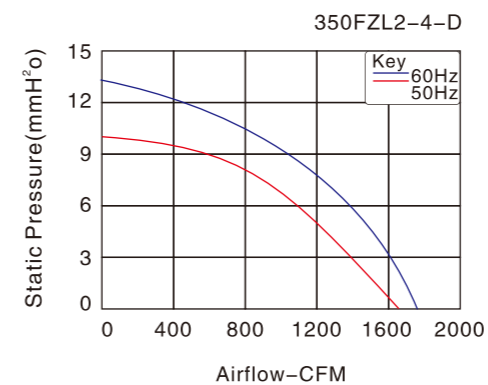

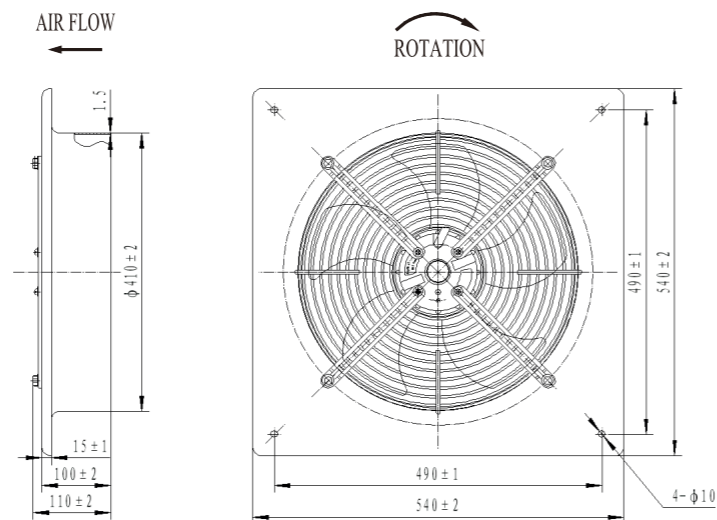

尺寸 Size: 540mm × 540mm × 110mm  
风量 Airflow: 1977–2589CFM  
噪音 Noise: 58–70dB(A)  
风叶 Impeller Material: Metal  
马达 Motor: Capacitor-Run And External Rotor Induction Motor  
引线 Lead Wire: Teflon18#UL 1332(Optional)  
温度范围 Operating Temperature: -10°C~+65°C  
防护等级 Type of protection: IP44  
绝缘等级 Insulation class: "F"

产品型号 Model	轴承型式 Bearing System	电压 Voltage VAC	频率 Freq. Hz	电流 Current A	功率 Power W	转速 Speed RPM	噪音 Noise dB(A)	风量 Air Flow CFM	相数 Phase	电容 Capacitor μF/VAC
400FZL2-D	Ball	200/240	50/60	0.8	180	1400/1560	68/70	2400/2589	1	6/500
400FZL3-D	Ball	380/420	50/60	0.4	180	1400/1560	68/70	2400/2589	3	—
400FZL4-D	Ball	380/420	50/60	0.45	180	1400/1560	68/70	2400/2589	1	4/500
400FZL10-D	Ball	200/240	50/60	0.5	112	950/1050	58/61	1977/2130	1	4/500
400FZL11-D	Ball	380/420	50/60	0.35	112	950/1050	58/61	1977/2130	3	—
400FZL12-D	Ball	380/420	50/60	0.4	112	950/1050	58/61	1977/2130	1	2.2/500

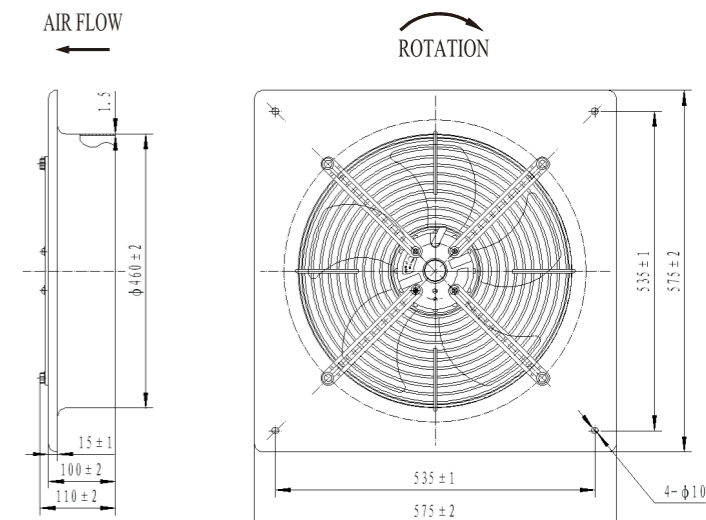
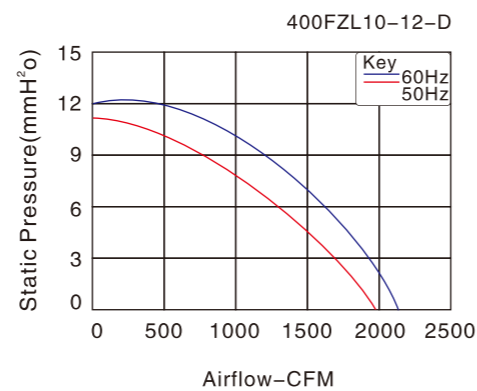
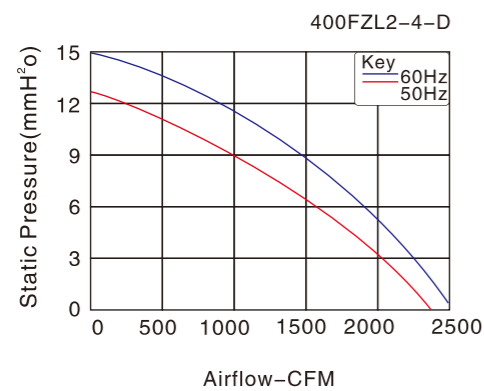

尺寸 Size: 575mm × 575mm × 110mm  
风量 Airflow: 2624–3413CFM  
噪音 Noise: 59–73dB(A)  
风叶 Impeller Material: Metal  
马达 Motor: Capacitor-Run And External Rotor Induction Motor  
引线 Lead Wire: Teflon18#UL 1332(Optional)  
温度范围 Operating Temperature: -10°C~+65°C  
防护等级 Type of protection: IP44  
绝缘等级 Insulation class: "F"

产品型号 Model	轴承型式 Bearing System	电压 Voltage VAC	频率 Freq. Hz	电流 Current A	功率 Power W	转速 Speed RPM	噪音 Noise dB(A)	风量 Air Flow CFM	相数 Phase	电容 Capacitor μF/VAC
450FZL2-D	Ball	200/240	50/60	1.15	250	1350/1450	70/73	3154/3413	1	8/500
450FZL3-D	Ball	380/420	50/60	0.52	250	1350/1450	70/73	3154/3413	3	—
450FZL4-D	Ball	380/420	50/60	0.6	250	1350/1450	70/73	3154/3413	1	4/500
450FZL10-D	Ball	200/240	50/60	0.71	160	920/1040	59/62	2624/2813	1	6/500
450FZL11-D	Ball	380/420	50/60	0.40	160	920/1040	59/62	2624/2813	3	—
450FZL12-D	Ball	380/420	50/60	0.45	160	920/1040	59/62	2624/2813	1	3/500

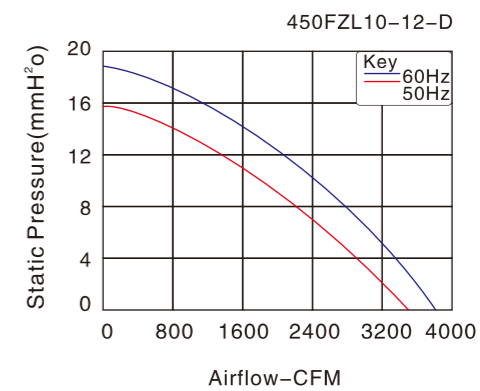
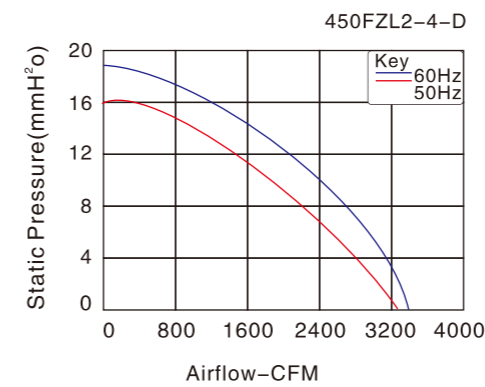

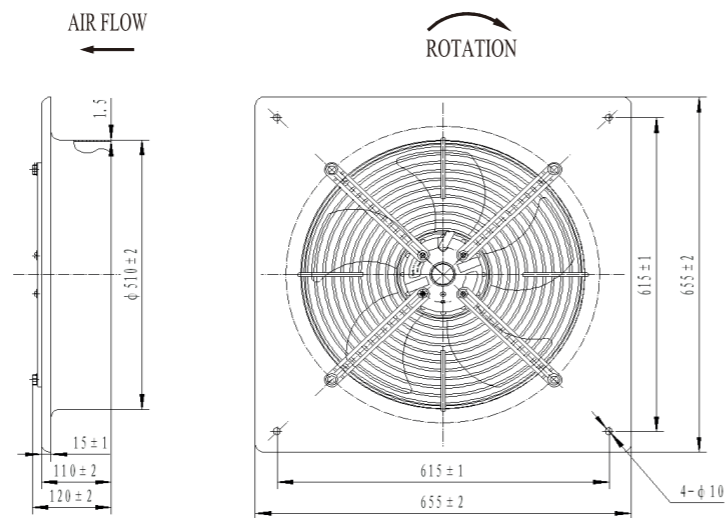

尺寸 Size: 655mm × 655mm × 120mm  
风量 Airflow: 3266–3859CFM  
噪音 Noise: 65–73dB(A)  
风叶 Impeller Material: Metal  
马达 Motor: Capacitor-Run And External Rotor Induction Motor  
引线 Lead Wire: Teflon18#UL 1332(Optional)  
温度范围 Operating Temperature: -10°C~+65°C  
防护等级 Type of protection: IP44  
绝缘等级 Insulation class: "F"

产品型号 Model	轴承型式 Bearing System	电压 Voltage VAC	频率 Freq. Hz	电流 Current A	功率 Power W	转速 Speed RPM	噪音 Noise dB(A)	风量 Air Flow CFM	相数 Phase	电容 Capacitor μF/VAC
500FZL2-D	Ball	200/240	50/60	1.8	480	1350/1470	70/73	3589/3895	1	4/500
500FZL3-D	Ball	380/420	50/60	0.9	480	1350/1470	70/73	3589/3895	3	—
500FZL4-D	Ball	380/420	50/60	1.2	480	1350/1470	70/73	3589/3895	1	5/500
500FZL10-D	Ball	200/240	50/60	1.2	240	925/1020	65/68	3266/3431	1	8/500
500FZL11-D	Ball	380/420	50/60	0.5	240	925/1020	65/68	3266/3431	3	—
500FZL12-D	Ball	380/420	50/60	0.65	240	925/1020	65/68	3266/3431	1	4/500

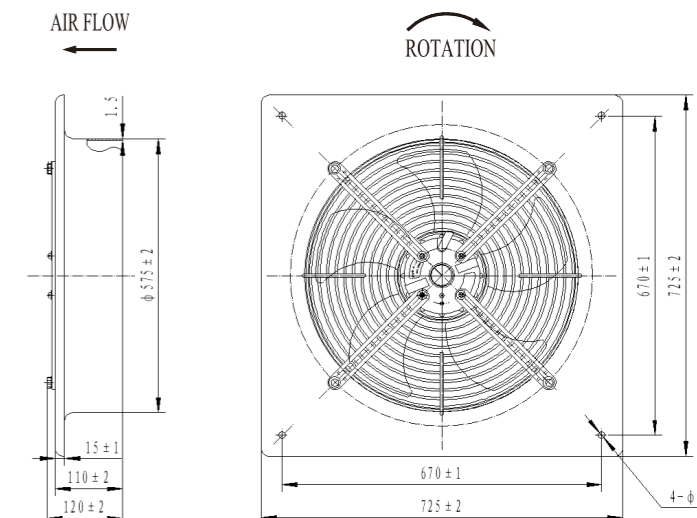
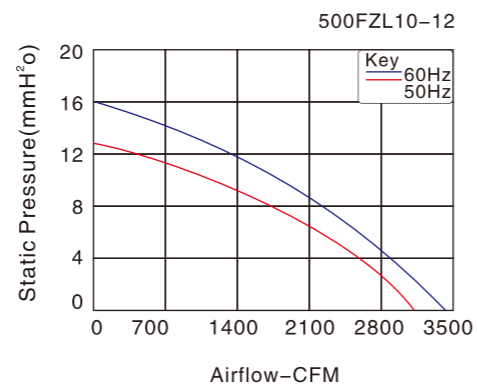
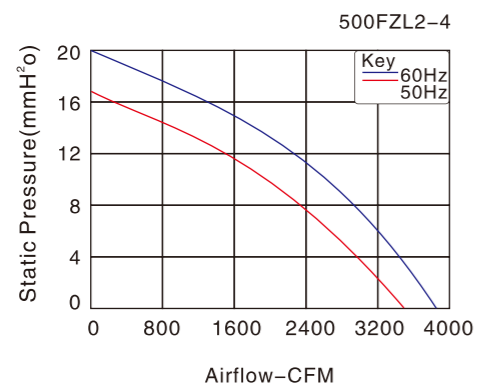

尺寸 Size: 725mm × 725mm × 120mm  
风量 Airflow: 3653–5237CFM  
噪音 Noise: 68–73dB(A)  
风叶 Impeller Material: Metal  
马达 Motor: Capacitor-Run And External Rotor Induction Motor  
引线 Lead Wire: Teflon18#UL 1332(Optional)  
温度范围 Operating Temperature: -10°C~+65°C  
防护等级 Type of protection: IP44  
绝缘等级 Insulation class: "F"

产品型号 Model	轴承型式 Bearing System	电压 Voltage VAC	频率 Freq. Hz	电流 Current A	功率 Power W	转速 Speed RPM	噪音 Noise dB(A)	风量 Air Flow CFM	相数 Phase	电容 Capacitor μF/VAC
550FZL2-D	Ball	200/240	50/60	2.1	500	1300/1420	70/73	4825/5237	1	10/500
550FZL3-D	Ball	380/420	50/60	0.95	500	1300/1420	70/73	4825/5237	3	—
550FZL4-D	Ball	380/420	50/60	1.5	500	1300/1420	70/73	4825/5237	1	5/500
550FZL10-D	Ball	200/240	50/60	1.2	280	900/980	68/71	3653/4013	1	8/500
550FZL11-D	Ball	380/420	50/60	0.72	280	900/980	68/71	3653/4013	3	—
550FZL12-D	Ball	380/420	50/60	0.85	280	900/980	68/71	3653/4013	1	4/500

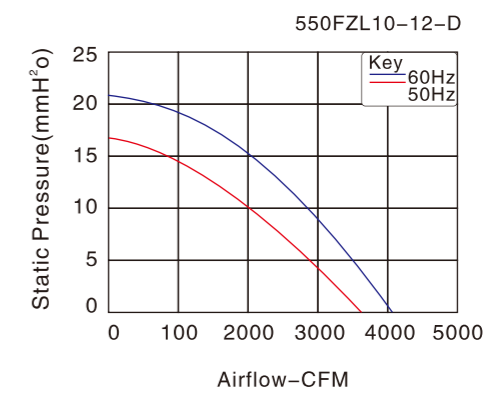
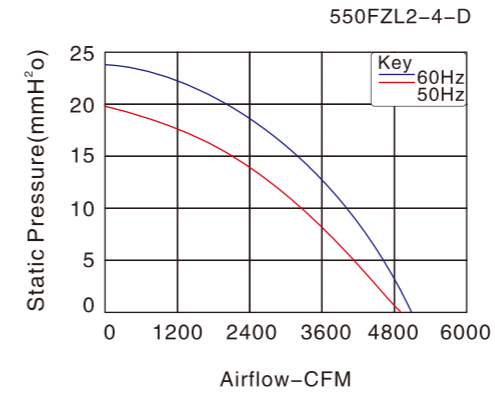

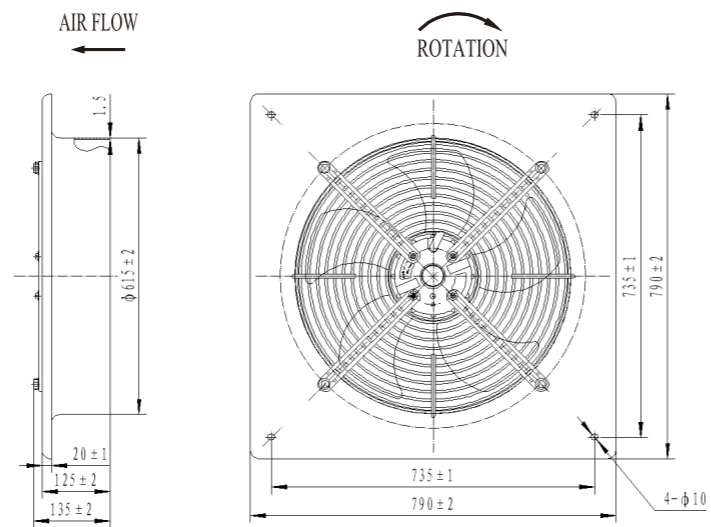

尺寸 Size: 790mm × 790mm × 135mm  
风量 Airflow: 4825-5437CFM  
噪音 Noise: 70-80dB(A)  
风叶 Impeller Material: Metal  
马达 Motor: Capacitor-Run And External Rotor Induction Motor  
引线 Lead Wire: Teflon18#UL 1332(Optional)  
温度范围 Operating Temperature: -10°C~+65°C  
防护等级 Type of protection: IP44  
绝缘等级 Insulation class: "F"

产品型号 Model	轴承型式 Bearing System	电压 Voltage VAC	频率 Freq. Hz	电流 Current A	功率 Power W	转速 Speed RPM	噪音 Noise dB(A)	风量 Air Flow CFM	相数 Phase	电容 Capacitor μF/VAC
600FZL10-D	Ball	200/240	50/60	2.4	520	900/950	70/78	4825/5237	1	10/500
600FZL11-D	Ball	380/420	50/60	1.4	520	900/950	70/78	4825/5237	3	/
600FZL4-D	Ball	380/420	50/60	1.6	820	1300/1400	73/80	4925/5437	3	/

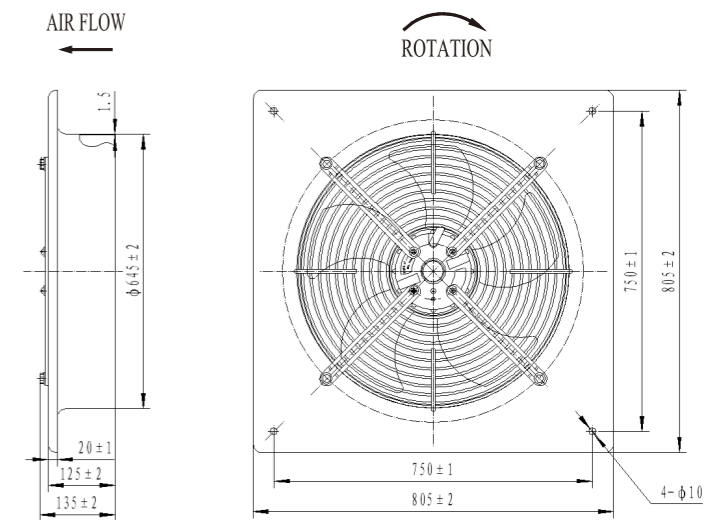
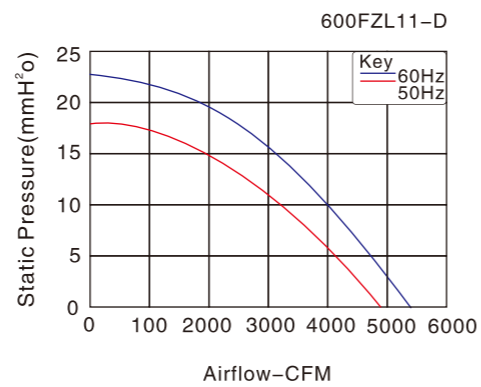
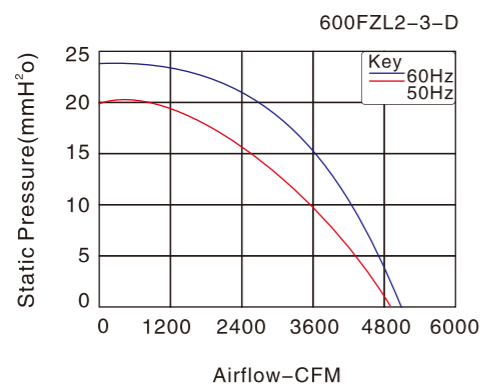

尺寸 Size: 805mm × 805mm × 135mm  
风量 Airflow: 9000-13500CFM  
噪音 Noise: 60-79dB(A)  
风叶 Impeller Material: Metal  
马达 Motor: Capacitor-Run And External Rotor Induction Motor  
引线 Lead Wire: Teflon18#UL 1332(Optional)  
温度范围 Operating Temperature: -10°C~+65°C  
防护等级 Type of protection: IP44  
绝缘等级 Insulation class: "F"

产品型号 Model	轴承型式 Bearing System	电压 Voltage VAC	频率 Freq. Hz	电流 Current A	功率 Power W	转速 Speed RPM	噪音 Noise dB(A)	风量 Air Flow CFM	相数 Phase	电容 Capacitor μF/VAC
630FLZ2-D	Ball	200-240	50/60	4.5/3.0	920/680	1300/1500	75/79	11000/13500	1	12/500
630FLZ3-D	Ball	380-420	50/60	1.8/1.8	800/850	1300/1480	75/79	13000/14000	3	/
630FLZ10-D	Ball	200-240	50/60	1.45/1.8	360/420	900/1100	70/73	9500/12800	1	8/500
630FLZ11-D	Ball	380-420	50/60	1.3/1.2	400/460	900/1100	70/73	9500/12000	3	/
630FLZ13-D	Ball	200-240	50/60	1.5/1.6	250/300	700/720	60/65	9000/9600	1	5/500

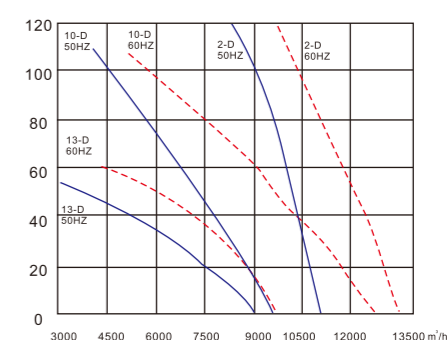
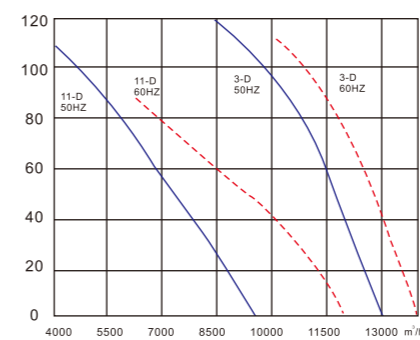

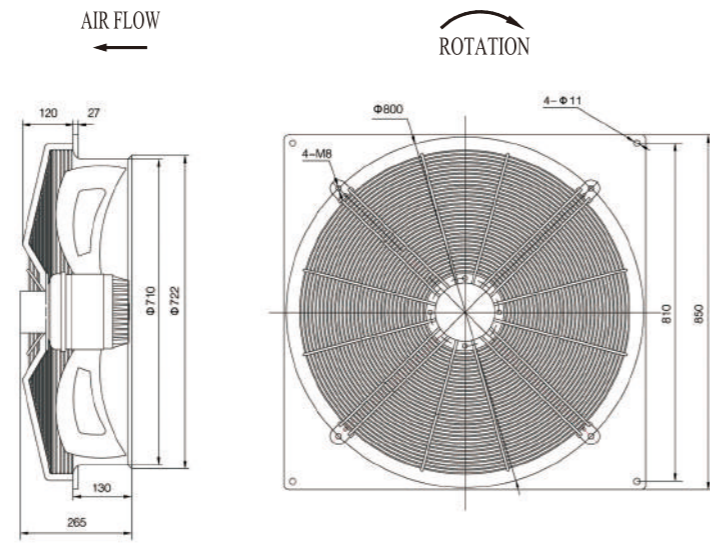

尺寸 Size: 850mm × 850mm × 265mm  
 风量 Airflow: 7509~9229CFM  
 噪音 Noise: 80dB(A)  
 风叶 Impeller Material: Metal  
 马达 Motor: Capacitor-Run And External Rotor Induction Motor  
 引线 Lead Wire: Teflon18#UL 1332(Optional)  
 温度范围 Operating Temperature: -10℃~+65℃  
 防护等级 Type of protection: IP44  
 绝缘等级 Insulation class: "F"

产品型号 Model	轴承型式 Bearing System	电压 Voltage VAC	频率 Freq. Hz	电流 Current A	功率 Power W	转速 Speed RPM	风量 Air Flow CFM	接线方式 Connection way	噪音 Noise dB(A)
710FZL12-D	Ball	380	50	1.9/1.15	900/650	900/730	9229/7509	△/Y	80

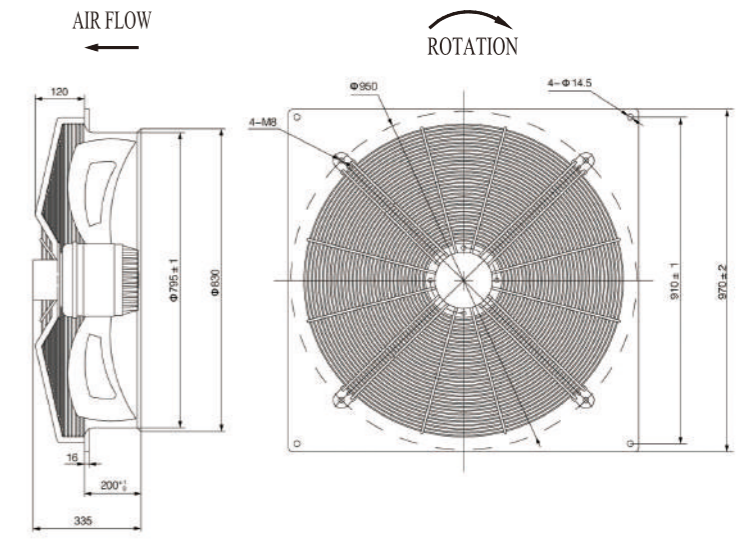
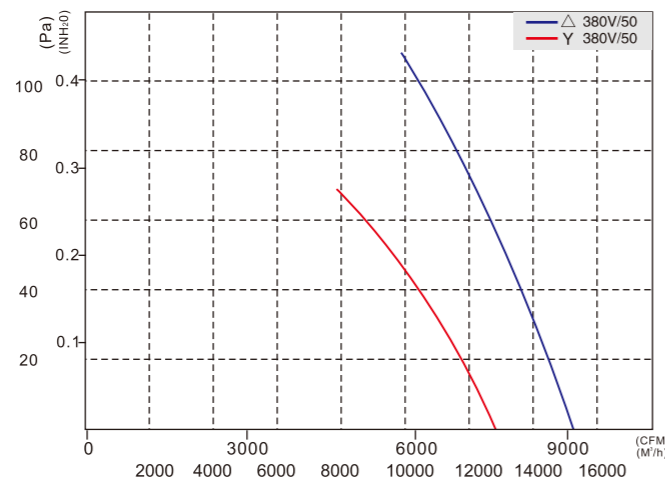

尺寸 Size: 970mm × 970mm × 335mm  
 风量 Airflow: 9476~11802CFM  
 噪音 Noise: 82dB(A)  
 风叶 Impeller Material: Metal  
 马达 Motor: Capacitor-Run And External Rotor Induction Motor  
 引线 Lead Wire: Teflon18#UL 1332(Optional)  
 温度范围 Operating Temperature: -10℃~+65℃  
 防护等级 Type of protection: IP44  
 绝缘等级 Insulation class: "F"

产品型号 Model	轴承型式 Bearing System	电压 Voltage VAC	频率 Freq. Hz	电流 Current A	功率 Power W	转速 Speed RPM	风量 Air Flow CFM	接线方式 Connection way	噪音 Noise dB(A)
800FZL12-D	Ball	380	50	2.85/1.6	1200/930	920/770	11802/9476	△/Y	82

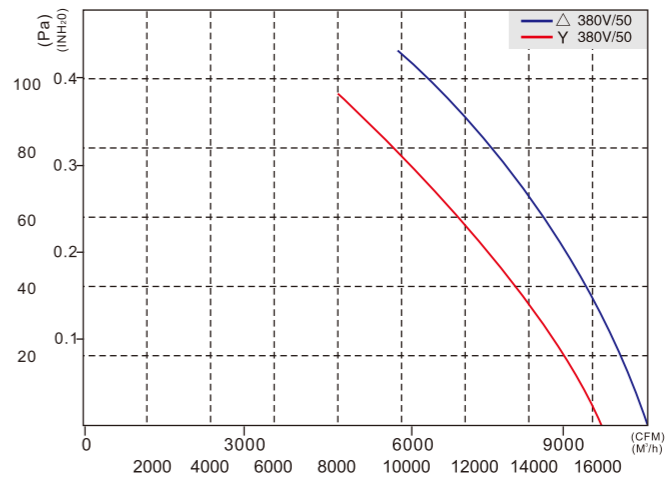

# CONTENTS

## 目录

### DC轴流风机 99/147

DC Axial Fan

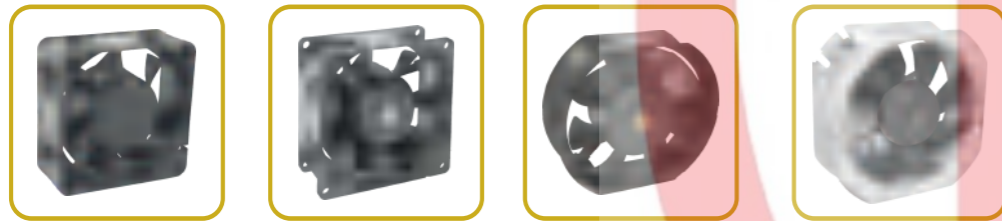

### DC离心风机 148/162

DC Centrifugal Fan

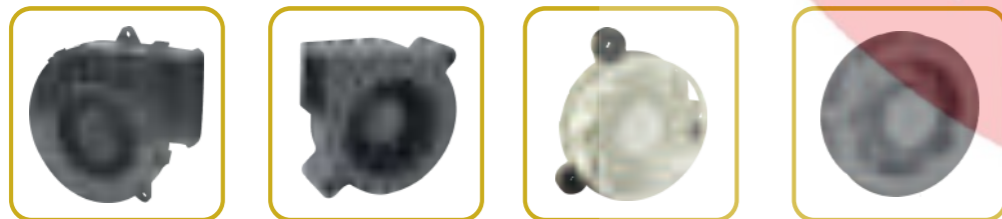

## Fan Part Number Definition

JL 80 25 M 12 S — P F 1 A  
 [1] [2] [3] [4] [5] [6] [7] [8] [9] [10] [11]

#### 【1】公司代码，以1码表示

JL: 九龙

#### 【2】外型尺寸，以2码表示

25: 25x25mm	30: 30x30mm
40: 40x40mm	50: 50x50mm
52: 52x52mm	60: 60x60mm
70: 70x70mm	80: 80x80mm
92: 92x92mm	12: 120x120mm
17: 172x150mm	20: 200*200mm

#### 【3】外型厚度，以2码表示

07: 7mm	08: 8mm
10: 10mm	15: 15mm
20: 20mm	25: 25mm
28: 28mm	38: 38mm
51: 51mm	60: 60mm

#### 【4】转速，以1或2码表示

S: SUPER LOW      L: LOW SPEED  
 M: MIDDLE SPEED    H: HIGH SPEED  
 U: SUPER HIGH

#### 【5】电压，以2码表示

DC电压:  
 03: 03V                      05: 05V  
 12: 12V                      24: 24V  
 48: 48V                      110: D1V  
 AC电压:  
 110V: A1V                    220V: A2V

#### 【6】轴承，以1码表示

S: SLEEVE BEARING  
 B: 2 BALL BEARING

#### 【7】分隔符，无实际意义。

#### 【8】FUNCTION，以1码表示

N: NORMAL，没有AUTO RESTART功能  
 R: 带有AUTO RESTART功能  
 T: 温控  
 W: 防水(Waterproof)  
 P: PWM CONTROL  
 L: 带LED  
 O: OTHER OPTION

#### 【9】电性信号输出，以1码表示

N: 无信号输出  
 F: FG  
 H: RD/HIGH  
 L: RD/LOW  
 O: OTHER OPTION

#### 【10】框叶特性，以1码表示

1: 普通PBT (黑色) 框叶  
 2: 轴流支架底座  
 3: Blower框叶  
 4: 静翼框  
 5: 涡轮转子(离心机)  
 6: 液压框  
 7: 框 + 护网  
 8: PC框叶+LED  
 9: 表示OTHER OPTION

#### 【11】线材标签特性,以1码表示

本样册仅做选型参考,具体以规格书为准。  
 This sample book is for reference only. Please refer to the specification for details.

如需特殊电压也可根据洽询提供，本公司保留技术改动权利。  
 Special voltage may be provided if necessary according to the inquiry. Jiulong all technical modification rights reserved.

# 九龙电机

# GENERAL SPECIFICATIONST

## OPERATING TEMPERATURE

- ◆ Ball Bearings..... -10°C to +70°C /15%~60%RH

## BEARING SYSTEM LIFE

- ◆ 2 Ball Bearings..... 70,000 hours @ 45°C
- ◆ Sleeve Bearings.....30,000 hours @ 45°C

## IMPELLER/FRAME

- ◆ Material..... PBT + Glass Fiber
- ◆ Flammability..... UL94V-0
- ◆ Color.....Black is standard

## STORAGE TEMPERATURE

- ◆ ALL..... -40°C to +70°C

## INSULATION RESISTANCE

- ◆ Standard..... Min.10 MΩ at 500VDC between frame and (+)terminal

## DIELECTRIC STRENGTH

- ◆ Standard..... -40°C to +70°C

## INSULATION RESISTANCE

- ◆ Standard..... 5mA max.at 500VAC 60Hz 1 minute between frame at (+)terminal

## NOISE DATE

- ◆ Noise measurements are performed in an Anechoic Chamber with less than 19dBA background noise in compliance with ISO7779 standards.1m from intake side.

## FRAME TYPE

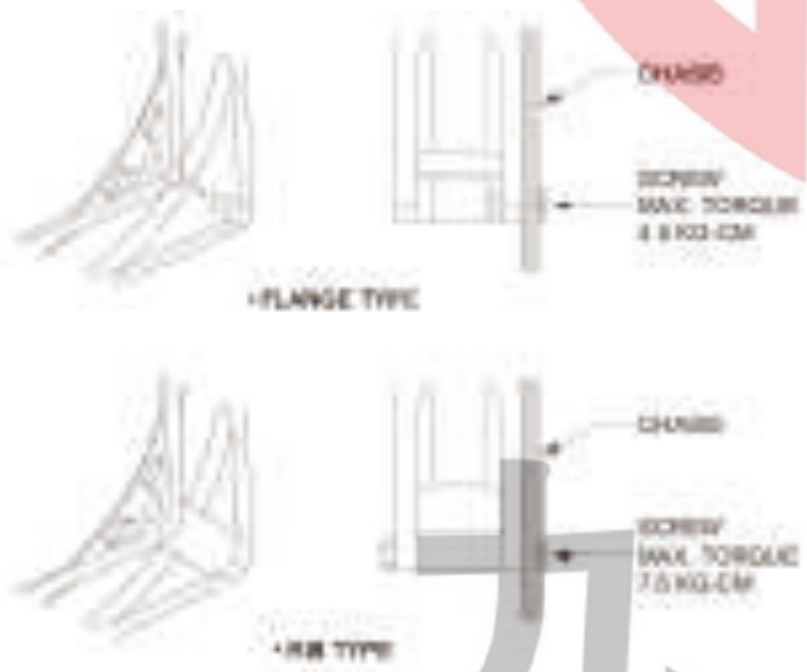

## Pulse Sensor/ Tachometer Signal/ FG

Pulse Sensor is for detecting the rotational speed of the fan motor. At locked rotor condition, the signal stops cycling and the output fix at VH or VL.

### Output Waveform

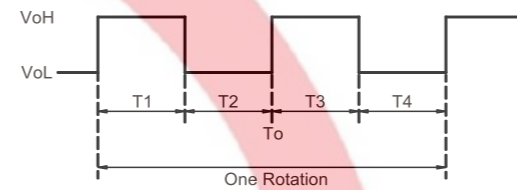

$T1-4 = (1/4) T$   
 $N = \text{Fan Rotational Speed (min}^{-1}\text{)}$

FG Signal Output Circuit:  
Open Collector

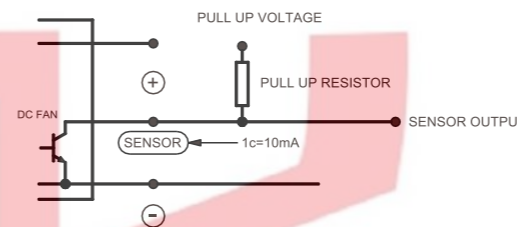

## Lock Sensor/ Rotation Detector

Lock Sensor is used to detect the fan motor is operating or stopped.

### Output Waveform

Alarm High: The output will be logical low when fan is operating and be logical high when fan motor is locked.



Alarm Low: The output will be logical low when fan is operating and be logical high when fan motor is locked.



RD Signal Output Circuit:  
Open Collector

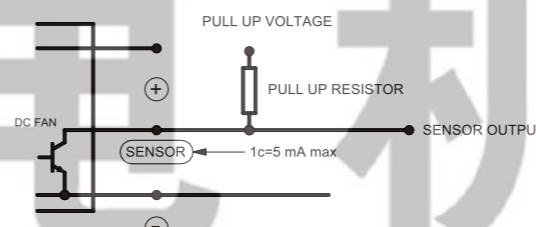

## Auto Restart Protection/ Current Limit

When the fan motor is locked, the device will cut off the drive current within two to six seconds and restart automatically after a few seconds. If the lock situation is continued, the device will work on repeated cycle of cut-off and restart until lock is released.

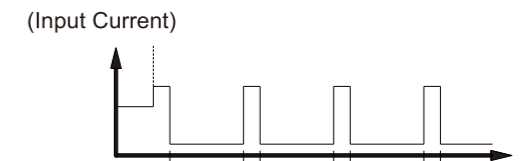
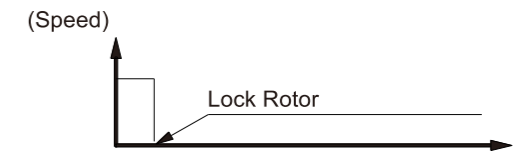

## PWM Control Signal

A speed control lead can be provided that will accept a PWM signal from the customer circuit to vary the speed of the fan. The change in speed is linear by changing the Duty-Cycle of the PWM.

$T = T_1 + T_2$ ,  $\alpha = T_1 / T$   
 $\alpha = \text{Duty-Cycle}$   
 $V_a = \alpha \times V_s$

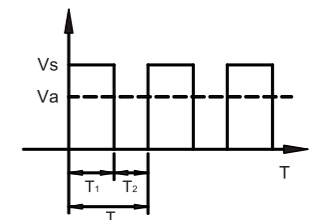

Open collector type and pull-up voltage is changed by maximum operating voltage and sink current by consuming current.

## Temperature Sensor

NS TECH uses a thermistor to sense temperature in the thermally controlled fan. The thermistor can be controlled by on board or off board with special length leads. The RPM and temperature range is subject to custom request.

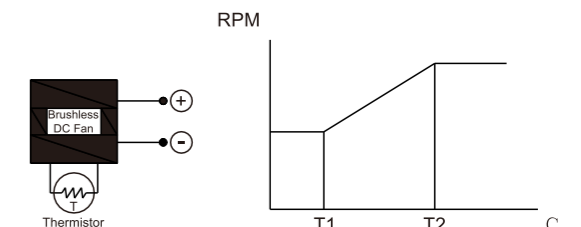



JULONG MOTOR  
AC/DC FANS COOLING FANS



本样图仅供参考，具体以规格书为准。  
This sample book is for reference only. Please refer to the specification for details.  
如需特殊电压也可根据规格书提供。本公司保留技术知识产权。  
Special voltage may be provided according to the requirement, although technical modification is reserved.

Http://www.xtgygs.cn



### DIMENSIONS DRAWING

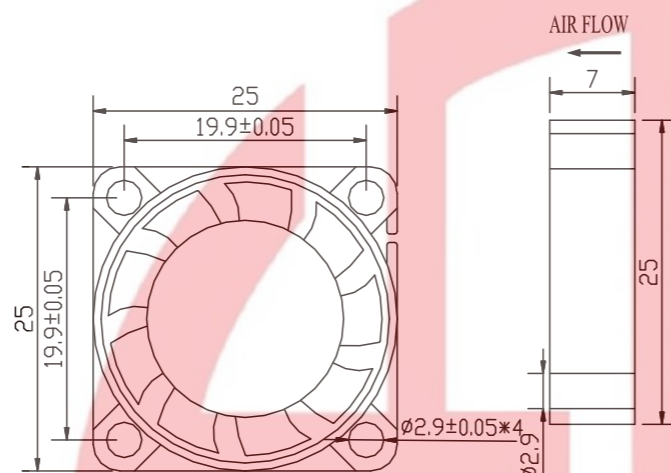

### DC AXIAL FAN 25\*25\*07MM SERIES

Material  
UL 1007 AWG # 28 OR Equivalent  
Red Wire:Positive (+)  
Black Wire:Negative (-)  
Yellow wire:FG or RD Signal

### P & Q CURVE (AT RATED VOLTAGE)

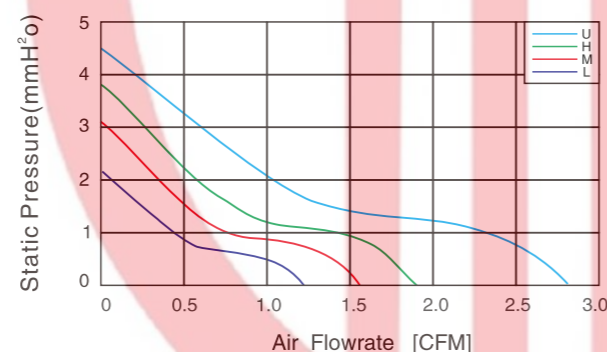

MODEL NO	RATED VOLTAGE V	OPERATING VOLTAGE V	RATED CURRENT A	ACTUAL CURRENT A	RATED POWER	RATED SPEED RPM (±10%)	MAX. AIR FLOW		MAX.STATIC AIR PRESSURE		NOISE LEVEL db(A)
							CMM	CFM	InH2O	mmH2O	
JL2507L05	5	3.6~6.8	0.11	0.09	0.55	7000	0.035	1.22	0.085	2.16	19.6
JL2507L12	12	6.0~13.5	0.03	0.01	0.36	7000	0.035	1.22	0.085	2.16	19.6
JL2507M05	5	3.6~6.8	0.17	0.15	0.85	10000	0.044	1.55	0.122	3.1	23.5
JL2507M12	12	6.0~13.5	0.06	0.04	0.72	10000	0.044	1.55	0.122	3.1	23.5
JL2507H05	5	3.6~6.8	0.23	0.21	1.15	14000	0.054	1.9	0.15	3.8	26.4
JL2507H12	12	6.0~13.5	0.09	0.07	1.08	14000	0.054	1.9	0.15	3.8	26.4
JL2507H05-HH	5	3.6~6.8	0.3	0.28	1.5	17000	0.08	2.81	0.177	4.5	31.2
JL2507H12-HH	12	6.0~13.5	0.1	0.08	1.2	17000	0.08	2.81	0.177	4.5	31.2



### DC AXIAL FAN 25\*25\*10MM SERIES

Material  
UL 1007 AWG # 28 OR Equivalent  
Red Wire:Positive (+)  
Black Wire:Negative (-)  
Yellow wire:FG or RD Signal

### DIMENSIONS DRAWING

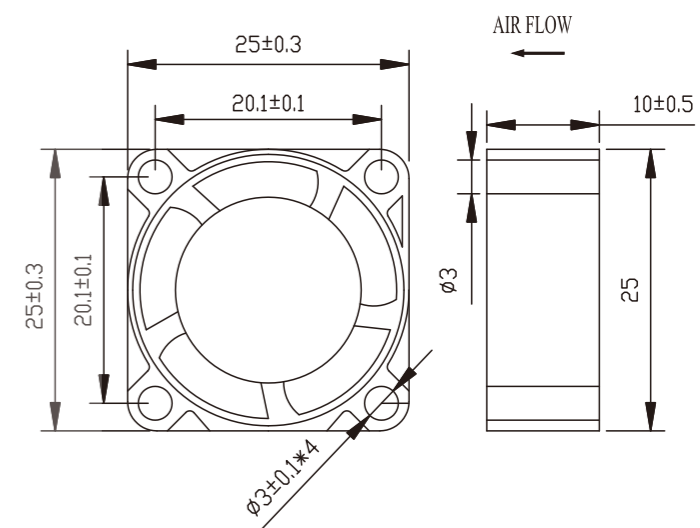

### P & Q CURVE (AT RATED VOLTAGE)

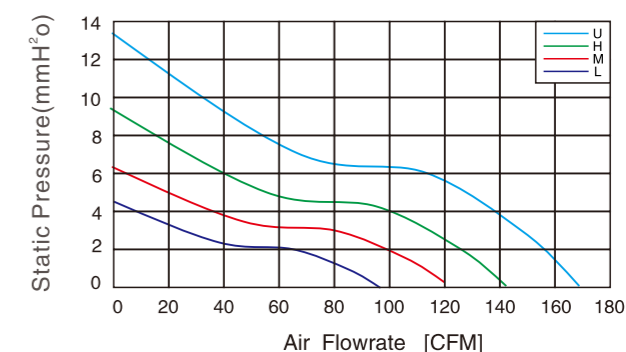

MODEL NO	RATED VOLTAGE V	OPERATING VOLTAGE V	RATED CURRENT A	ACTUAL CURRENT A	RATED POWER	RATED SPEED RPM (±10%)	MAX. AIR FLOW		MAX.STATIC AIR PRESSURE		NOISE LEVEL db(A)
							CMM	CFM	InH2O	mmH2O	
JL2510H05Y	5	4.5~5.5	0.18	0.16	0.9	4000	0.059	2.1	0.334	8.48	26.5
JL2510M05Y	5	4.5~5.5	0.16	0.14	0.8	3400	0.045	1.58	0.211	5.37	23
JL2510L05Y	5	4.5~5.5	0.12	0.12	0.6	2800	0.026	0.93	0.125	3.18	21.3
JL2510H12Y	12	9.5~13.2	0.09	0.08	1.08	13000	0.059	2.1	0.334	8.48	26.5
JL2510M12Y	12	9.5~13.2	0.08	0.07	0.96	10000	0.045	1.58	0.211	5.37	23
JL2510L12Y	12	9.5~13.2	0.07	0.06	0.84	8000	0.026	0.93	0.125	3.18	21.3

■ PS:Where Y can be S .B.

# 九 龙 电 机

AC Axial Fan  
AC轴流风机

AC All-Metal Axial Fan  
AC全金属轴流风扇

DC Axial Fan  
DC轴流风机

DC Centrifugal Fan  
DC离心风机

EC Axial Fan  
EC轴流风机

EC Centrifugal Fan  
EC离心风机

AC Centrifugal Fan  
AC离心风机

Fan Accessories  
风机配件



JULONG MOTOR  
AC/DC FANS COOLING FANS



本样图仅供参考，具体以实物为准。  
This sample book is for reference only. Please refer to the specification for details.  
如需特殊电压也可根据需求提供。本公司保留技术知识产权。  
Special voltage may be provided flexibly according to the requirement. All technical modification rights reserved.

Http://www.xtgygs.cn



### DIMENSIONS DRAWING

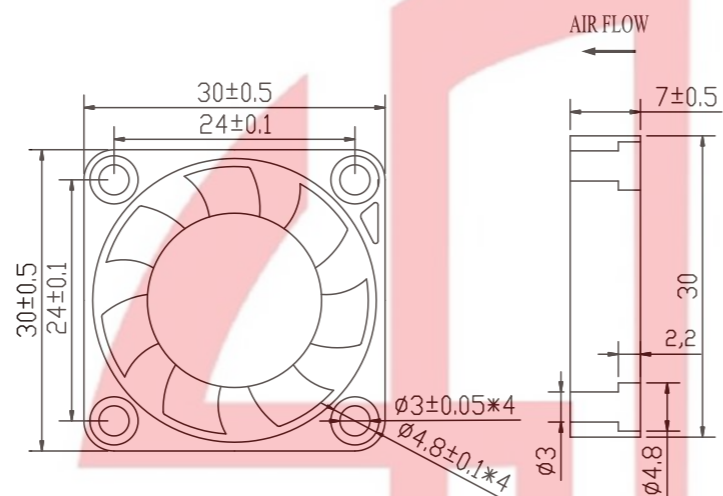

### DC AXIAL FAN 30\*30\*07MM SERIES

Material  
UL 1007 AWG # 28 OR Equivalent  
Red Wire:Positive (+)  
Black Wire:Negative (-)  
Yellow wire:FG or RD Signal

### P & Q CURVE (AT RATED VOLTAGE)

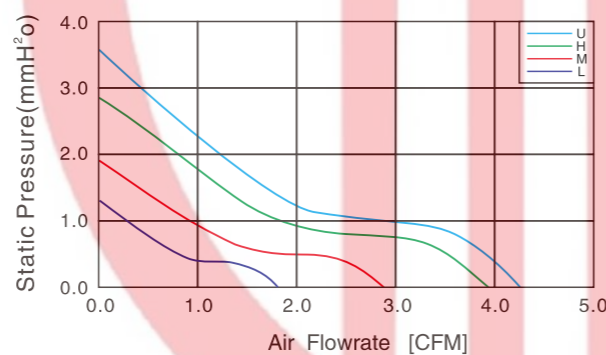

MODEL NO	RATED VOLTAGE V	OPERATING VOLTAGE V	RATED CURRENT A	ACTUAL CURRENT A	RATED POWER	RATED SPEED RPM (±10%)	MAX. AIR FLOW		MAX.STATIC AIR PRESSURE		NOISE LEVEL db(A)
							CMM	CFM	InH2O	mmH2O	
JL3007L05	5	3.6~6.8	0.12	0.10	0.6	5000	0.05	1.79	0.051	1.3	19.6
JL3007L12	12	6.0~13.5	0.04	0.02	0.48	5000	0.05	1.79	0.051	1.3	19.6
JL3007M05	5	3.6~6.8	0.17	0.15	0.85	8000	0.08	2.86	0.075	1.9	23.5
JL3007M12	12	6.0~13.5	0.06	0.04	0.72	8000	0.08	2.86	0.075	1.9	23.5
JL3007H05	5	3.6~6.8	0.25	0.23	1.25	11000	0.11	3.92	0.114	2.9	26.4
JL3007H12	12	6.0~13.5	0.1	0.08	1.2	11000	0.11	3.92	0.114	2.9	26.4
JL3007H05-HH	5	3.6~6.8	0.32	0.30	1.6	13000	0.12	4.25	0.141	3.58	31.2
JL3007H12-HH	12	6.0~13.5	0.12	0.10	1.44	13000	0.12	4.25	0.141	3.58	31.2

### DIMENSIONS DRAWING

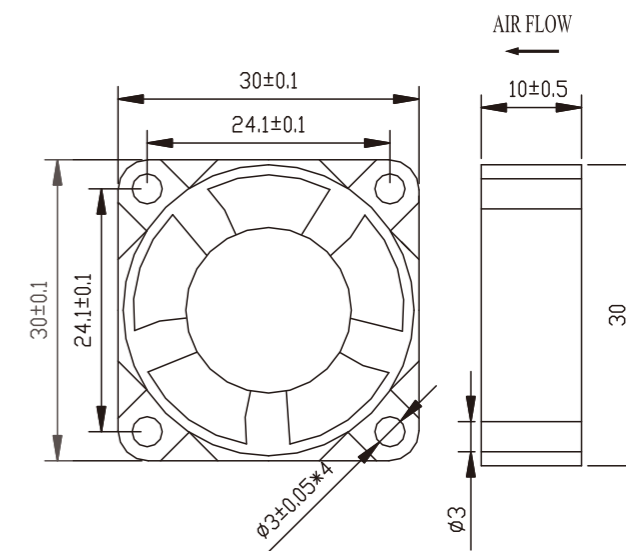

### DC AXIAL FAN 30\*30\*10MM SERIES

Material  
UL 1007 AWG # 28 OR Equivalent  
Red Wire:Positive (+)  
Black Wire:Negative (-)  
Yellow wire:FG or RD Signal

### P & Q CURVE (AT RATED VOLTAGE)

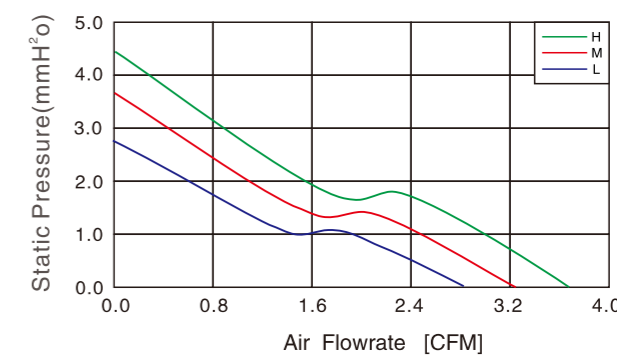

MODEL NO	RATED VOLTAGE V	OPERATING VOLTAGE V	RATED CURRENT A	ACTUAL CURRENT A	RATED POWER	RATED SPEED RPM (±10%)	MAX. AIR FLOW		MAX.STATIC AIR PRESSURE		NOISE LEVEL db(A)
							CMM	CFM	InH2O	mmH2O	
JL3010H05Y	5	4.5~5.5	0.2	0.18	1.0	10000	0.104	3.67	0.177	4.5	29.7
JL3010M05Y	5	4.5~5.5	0.16	0.14	0.8	9000	0.093	3.28	0.146	3.7	27.2
JL3010L05Y	5	4.5~5.5	0.13	0.11	0.65	8000	0.082	2.9	0.109	2.78	25.6
JL3010H12Y	12	9.5~13.2	0.13	0.11	1.56	10000	0.104	3.67	0.177	4.5	29.7
JL3010M12Y	12	9.5~13.2	0.10	0.09	1.2	9000	0.093	3.28	0.146	3.7	27.2
JL3010L12Y	12	9.5~13.2	0.08	0.07	0.96	8000	0.082	2.9	0.109	2.78	25.6

PS: Where Y can be S .B.

# 九 龙 电 机



JULONG MOTOR  
AC/DC FANS COOLING FANS



### DIMENSIONS DRAWING

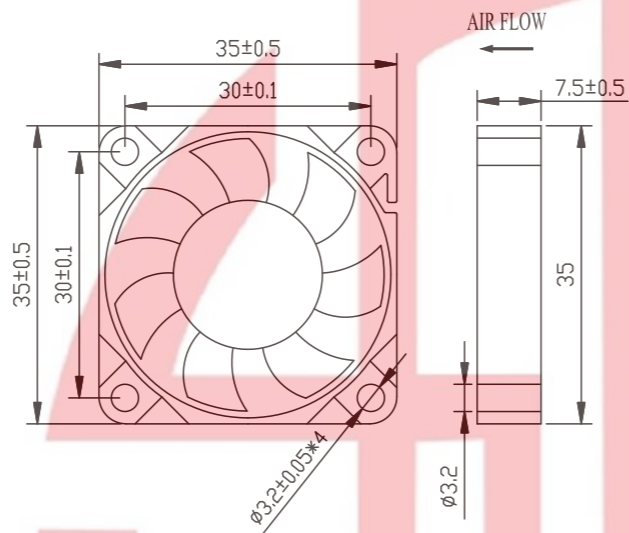

### P & Q CURVE (AT RATED VOLTAGE)

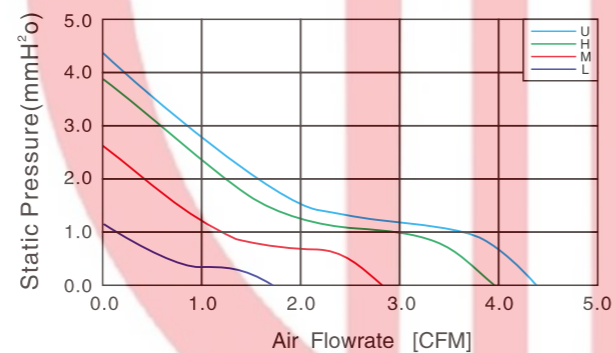

## DC AXIAL FAN 35\*35\*07MM SERIES

Material  
UL 1007 AWG # 28 OR Equivalent  
Red Wire:Positive (+)  
Black Wire:Negative (-)  
Yellow wire:FG or RD Signal

MODEL NO	RATED VOLTAGE V	OPERATING VOLTAGE V	RATED CURRENT A	ACTUAL CURRENT A	RATED POWER	RATED SPEED RPM (±10%)	MAX. AIR FLOW		MAX.STATIC AIR PRESSURE		NOISE LEVEL db(A)
							CMM	CFM	InH <sub>2</sub> O	mmH <sub>2</sub> O	
JL3507L05	5	3.6~6.8	0.11	0.09	0.55	4500	0.11	3.46	0.05	1.18	19.5
JL3507L12	12	6.0~13.5	0.04	0.02	0.48	4500	0.11	3.46	0.05	1.18	19.5
JL3507M05	5	3.6~6.8	0.17	0.15	0.85	6500	0.16	5.67	0.1	2.65	22.3
JL3507M12	12	6.0~13.5	0.06	0.04	0.72	6500	0.16	5.67	0.1	2.65	22.3
JL3507H05	5	3.6~6.8	0.25	0.23	1.25	9000	0.22	7.88	0.15	3.9	29.5
JL3507H12	12	6.0~13.5	0.1	0.08	1.2	9000	0.22	7.88	0.15	3.9	29.5
JL3507H05-HH	5	3.6~6.8	0.33	0.31	1.05	10000	0.25	8.75	0.17	4.4	32.6
JL3507H12-HH	12	6.0~13.5	0.12	0.10	1.44	10000	0.25	8.75	0.17	4.4	32.6



### DIMENSIONS DRAWING

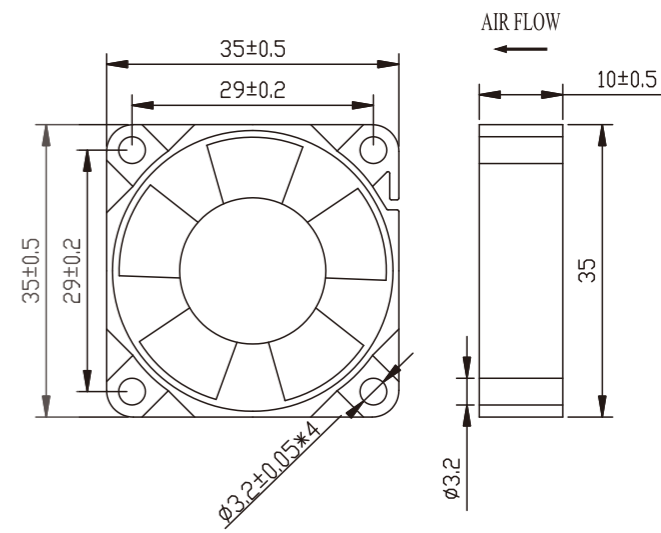

### P & Q CURVE (AT RATED VOLTAGE)

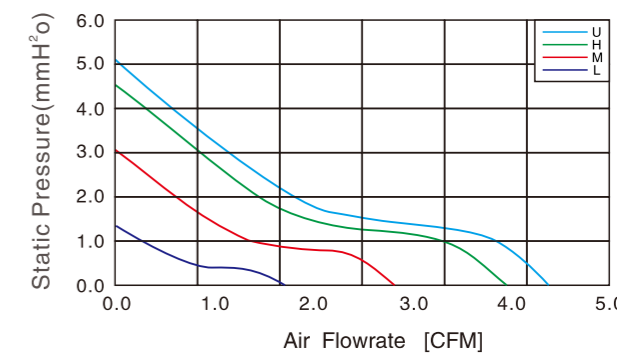

## DC AXIAL FAN 35\*35\*10MM SERIES

Material  
UL 1007 AWG # 28 OR Equivalent  
Red Wire:Positive (+)  
Black Wire:Negative (-)  
Yellow wire:FG or RD Signal

MODEL NO	RATED VOLTAGE V	OPERATING VOLTAGE V	RATED CURRENT A	ACTUAL CURRENT A	RATED POWER	RATED SPEED RPM (±10%)	MAX. AIR FLOW		MAX.STATIC AIR PRESSURE		NOISE LEVEL db(A)
							CMM	CFM	InH <sub>2</sub> O	mmH <sub>2</sub> O	
JL3510L05	5	3.6~6.8	0.09	0.07	0.45	5000	0.1	3.85	0.05	1.31	21.3
JL3510L12	12	6.0~13.5	0.04	0.02	0.48	5000	0.1	3.85	0.05	1.31	21.3
JL3510M05	5	3.6~6.8	0.13	0.11	0.65	6800	0.16	5.67	0.1	2.65	27.2
JL3510M12	12	6.0~13.5	0.06	0.04	0.72	6800	0.16	5.67	0.1	2.65	27.2
JL3510H05	5	3.6~6.8	0.2	0.18	1	8000	0.19	7.02	0.15	3.5	31.5
JL3510H12	12	6.0~13.5	0.08	0.06	0.96	8000	0.19	7.02	0.15	3.5	31.5
JL3510H05-HH	5	3.6~6.8	0.21	0.19	1.05	10000	0.25	8.67	0.17	4.23	34.2
JL3510H12-HH	12	6.0~13.5	0.09	0.07	1.08	10000	0.25	8.67	0.17	4.23	34.2
JL3510H05-VH	5	3.6~6.8	0.24	0.22	1.2	11500	0.25	9.61	0.19	4.84	35.3
JL3510H12-VH	12	6.0~13.5	0.1	0.08	1.2	11500	0.25	9.61	0.19	4.84	35.3



JILONG MOTOR  
AC/DC FANS COOLING FANS



UL 1007  
E248719



本样册仅供参考，具体以规格书为准。  
This sample book is for reference only. Please refer to the specification for details.  
如需特殊电压也可特别定制提供。本公司保留技术知识产权。  
Special voltage may be provided flexibly according to the requirement. All technical modification rights reserved.

Http://www.xtgygs.cn



DIMENSIONS DRAWING

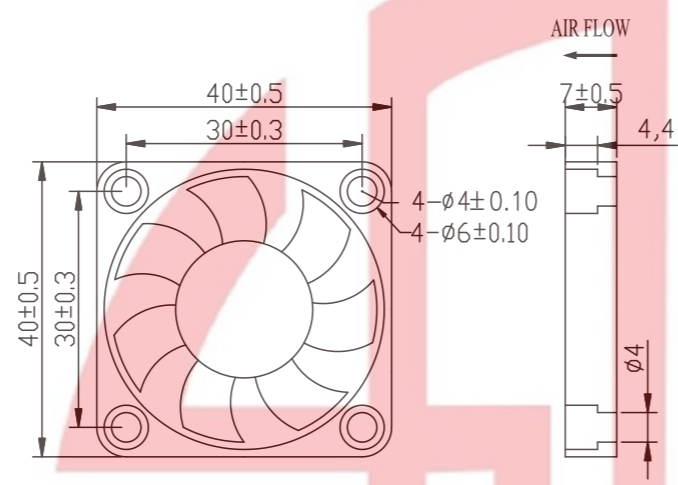

DC AXIAL FAN  
40\*40\*07MM SERIES

Material  
UL 1007 AWG # 28 OR Equivalent  
Red Wire:Positive (+)  
Black Wire:Negative (-)  
Yellow wire:FG or RD Signal

P & Q CURVE (AT RATED VOLTAGE)

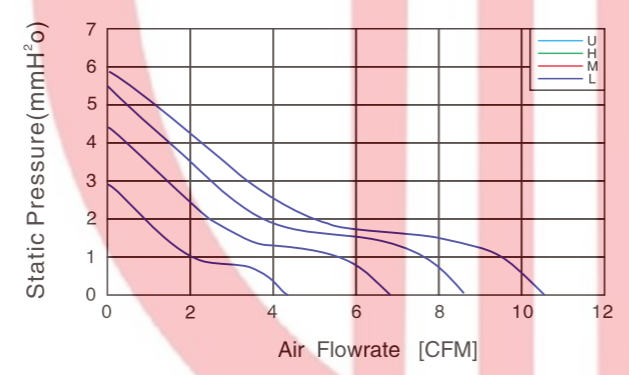

MODEL NO	RATED VOLTAGE V	OPERATING VOLTAGE V	RATED CURRENT A	ACTUAL CURRENT A	RATED POWER	RATED SPEED RPM (±10%)	MAX. AIR FLOW		MAX.STATIC AIR PRESSURE		NOISE LEVEL db(A)
							CMM	CFM	InH2O	mmH2O	
JL4007L05	5	3.6~6.8	0.12	0.10	0.6	4500	0.12	4.32	0.11	2.92	20.6
JL4007L12	12	6.0~13.5	0.04	0.02	0.48	4500	0.12	4.32	0.11	2.92	20.6
JL4007M05	5	3.6~6.8	0.18	0.16	0.9	6000	0.19	6.81	0.17	4.4	24.6
JL4007M12	12	6.0~13.5	0.06	0.04	0.72	6000	0.19	6.81	0.17	4.4	24.6
JL4007H05	5	3.6~6.8	0.22	0.20	1.1	7000	0.245	8.65	0.215	5.45	27.6
JL4007H12	12	6.0~13.5	0.08	0.06	0.96	7000	0.245	8.65	0.215	5.45	27.6
JL4007H05-HH	5	3.6~6.8	0.25	0.23	1.25	8000	0.31	10.58	0.23	5.9	31.8
JL4007H12-HH	12	6.0~13.5	0.1	0.08	1.2	8000	0.31	10.58	0.23	5.9	31.8

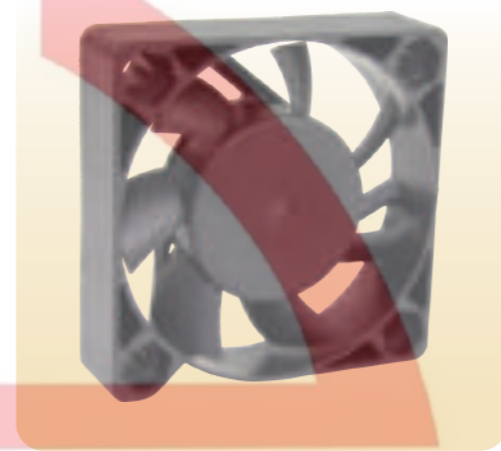

DIMENSIONS DRAWING

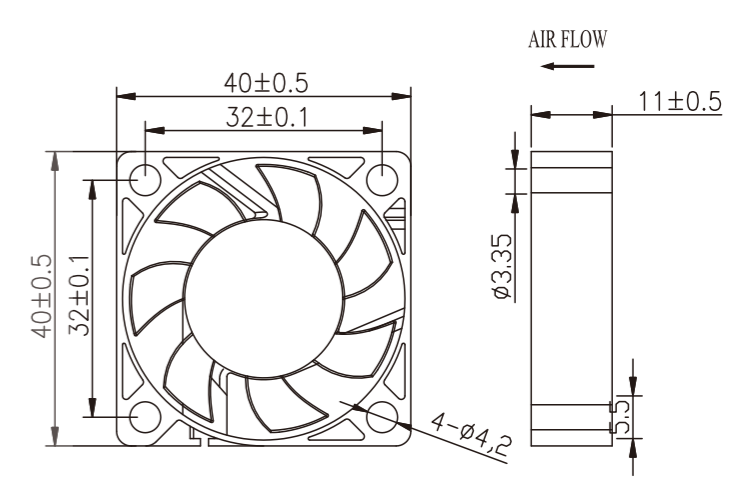

DC AXIAL FAN  
40\*40\*10MM SERIES

Material  
UL 1007 AWG # 28 OR Equivalent  
Red Wire:Positive (+)  
Black Wire:Negative (-)  
Yellow wire:FG or RD Signal

P & Q CURVE (AT RATED VOLTAGE)

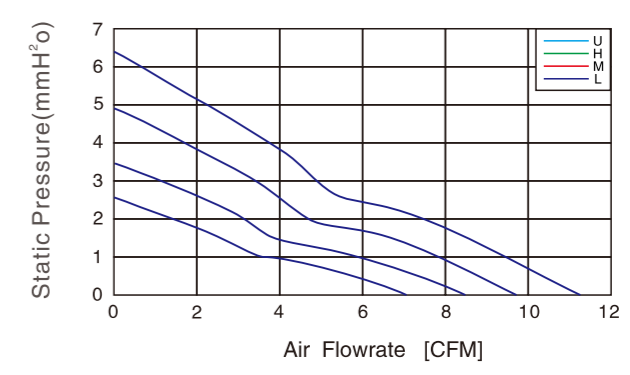

MODEL NO	RATED VOLTAGE V	OPERATING VOLTAGE V	RATED CURRENT A	ACTUAL CURRENT A	RATED POWER	RATED SPEED RPM (±10%)	MAX. AIR FLOW		MAX.STATIC AIR PRESSURE		NOISE LEVEL db(A)
							CMM	CFM	InH2O	mmH2O	
JL4010H05Y	5	4.5~5.5	0.25	0.22	1.25	7000	0.280	9.88	0.20	4.97	30.5
JL4010M05Y	5	4.5~5.5	0.20	0.17	1.0	6000	0.240	8.47	0.14	3.65	27.2
JL4010L05Y	5	4.5~5.5	0.13	0.11	0.65	5000	0.200	7.06	0.10	2.54	23.2
JL4010U12Y	12	9.5~13.2	0.18	0.16	2.16	8000	0.32	11.29	0.26	6.49	33.4
JL4010H12Y	12	9.5~13.2	0.12	0.10	1.44	7000	0.28	9.88	0.20	4.97	30.5
JL4010M12Y	12	9.5~13.2	0.09	0.08	1.08	6000	0.24	8.47	0.14	3.65	27.2
JL4010L12Y	12	9.5~13.2	0.08	0.07	0.96	5000	0.20	7.06	0.10	2.54	23.2

PS:Where Y can be S .B.

九 龙 电 机

AC Axial Fan  
AC轴流风机

AC All-Metal Axial Fan  
AC全金属轴流风扇

DC Axial Fan  
DC轴流风机

DC Centrifugal Fan  
DC离心风机

EC Axial Fan  
EC轴流风机

EC Centrifugal Fan  
EC离心风机

AC Centrifugal Fan  
AC离心风机

Fan Accessories  
风机配件



JULONG MOTOR  
AC/DC FANS COOLING FANS



### DIMENSIONS DRAWING

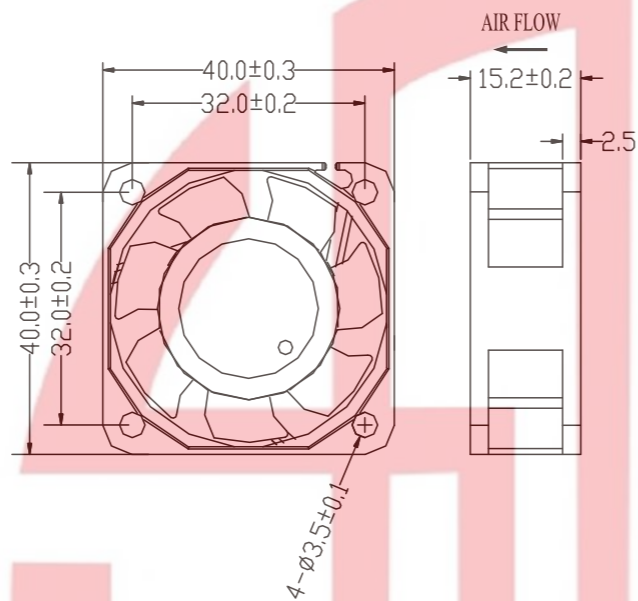

### P & Q CURVE (AT RATED VOLTAGE)

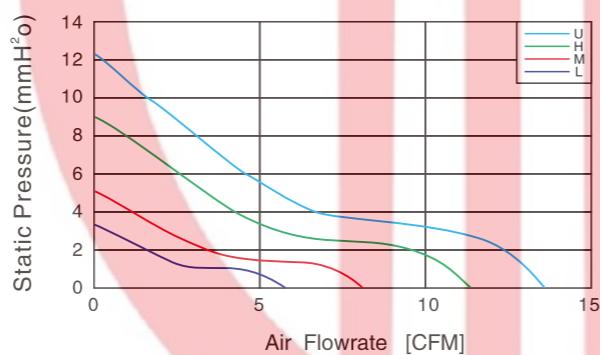

### DC AXIAL FAN 40\*40\*15MM SERIES

Material  
UL 1007 AWG # 26 OR Equivalent  
Red Wire:Positive (+)  
Black Wire:Negative (-)  
Yellow wire:FG or RD Signal

MODEL NO	RATED VOLTAGE V	OPERATING VOLTAGE V	RATED CURRENT A	ACTUAL CURRENT A	RATED POWER	RATED SPEED RPM (±10%)	MAX. AIR FLOW		MAX.STATIC AIR PRESSURE		NOISE LEVEL db(A)
							CMM	CFM	InH <sub>2</sub> O	mmH <sub>2</sub> O	
JL4015L05	5	3.6~6.8	0.12	0.10	0.6	4000	0.164	5.8	0.132	3.35	18.9
JL4015L12	12	6.0~13.5	0.05	0.03	0.6	4000	0.164	5.8	0.132	3.35	18.9
JL4015L24	24	18~26.5	0.04	0.02	0.96	4000	0.164	5.8	0.132	3.35	18.9
JL4015M05	5	3.6~6.8	0.21	0.19	1.05	6000	0.230	8.13	0.202	5.12	25.3
JL4015M12	12	6.0~13.5	0.1	0.08	1.2	6000	0.230	8.13	0.202	5.12	25.3
JL4015M24	24	18~26.5	0.08	0.06	1.92	6000	0.230	8.13	0.202	5.12	25.3
JL4015H12	12	6.0~13.5	0.14	0.12	1.68	8000	0.321	11.36	0.355	9.02	32.6
JL4015H24	24	18~26.5	0.1	0.08	2.4	8000	0.321	11.36	0.355	9.02	32.6
JL4015H12-HH	12	6.0~13.5	0.19	0.17	2.28	10000	0.385	13.6	0.484	12.3	39.6
JL4015H24-HH	24	18~26.5	0.12	0.10	2.88	10000	0.385	13.6	0.484	12.3	39.6



### DIMENSIONS DRAWING

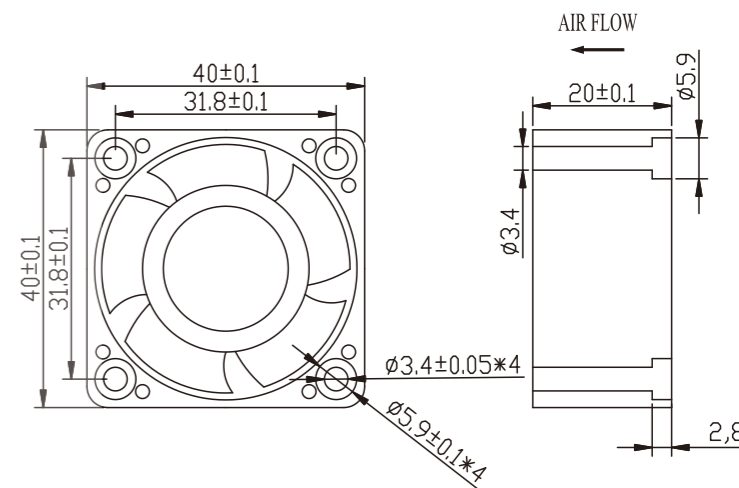

### P & Q CURVE (AT RATED VOLTAGE)

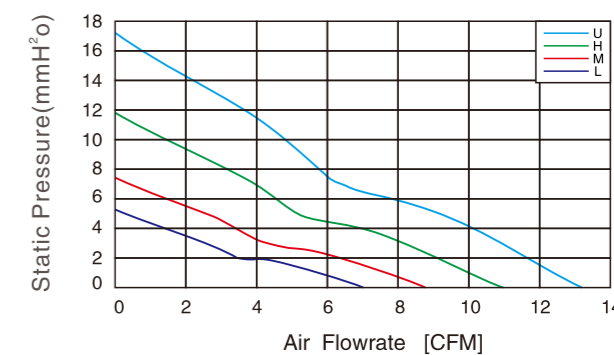

### DC AXIAL FAN 40\*40\*20MM SERIES

Material  
UL 1007 AWG # 26 OR Equivalent  
Red Wire:Positive (+)  
Black Wire:Negative (-)  
Yellow wire:FG or RD Signal

MODEL NO	RATED VOLTAGE V	OPERATING VOLTAGE V	RATED CURRENT A	ACTUAL CURRENT A	RATED POWER	RATED SPEED RPM (±10%)	MAX. AIR FLOW		MAX.STATIC AIR PRESSURE		NOISE LEVEL db(A)
							CMM	CFM	InH <sub>2</sub> O	mmH <sub>2</sub> O	
JL4020H12B	12	7~13.2	0.2	0.18	2.4	10000	0.305	10.76	0.463	11.760	30.7
JL4020M12B	12	7~13.2	0.09	0.08	1.08	8000	0.244	8.61	0.296	7.530	25.9
JL4020L12B	12	7~13.2	0.07	0.06	0.84	7000	0.213	7.53	0.227	5.760	23.0
JL4020U24B	24	14~26.4	0.11	0.1	2.64	12000	0.366	12.91	0.667	16.93	34.7
JL4020H24B	24	14~26.4	0.09	0.08	2.16	10000	0.305	10.76	0.463	11.760	30.7
JL4020M24B	24	14~26.4	0.04	0.03	0.96	8000	0.244	8.61	0.296	7.53	25.9
JL4020L24B	24	14~26.4	0.03	0.02	0.72	7000	0.213	7.53	0.227	5.76	23.0



JULONG MOTOR  
AC/DC FANS COOLING FANS



本样图仅供参考，具体以规格书为准。  
This sample book is for reference only. Please refer to the specification for details.  
如需特殊电压也可根据规格书提供。本公司保留技术知识产权。  
Special voltage may be provided flexibly according to the requirement. All technical modification rights reserved.

Http://www.xtgygs.cn



### DIMENSIONS DRAWING

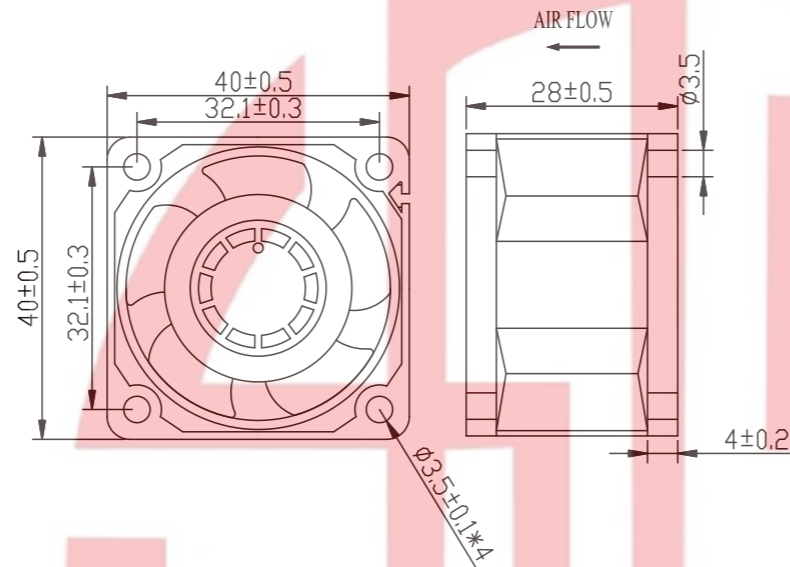

### P & Q CURVE (AT RATED VOLTAGE)

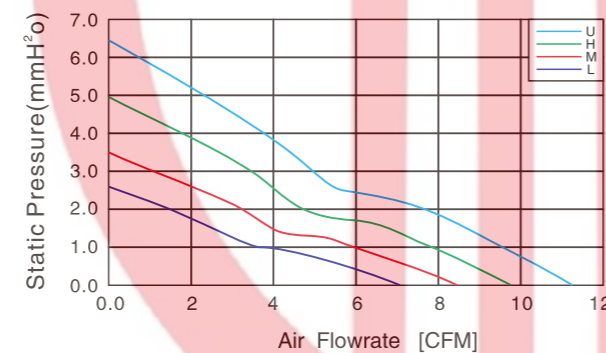

### DC AXIAL FAN 40\*40\*28MM SERIES

Material  
UL 1007 AWG # 26 OR Equivalent  
Red Wire:Positive (+)  
Black Wire:Negative (-)  
Yellow wire:FG or RD Signal

MODEL NO	RATED VOLTAGE V	OPERATING VOLTAGE V	RATED CURRENT A	ACTUAL CURRENT A	RATED POWER	RATED SPEED RPM (±10%)	MAX. AIR FLOW		MAX.STATIC AIR PRESSURE		NOISE LEVEL db(A)
							CMM	CFM	InH <sub>2</sub> O	mmH <sub>2</sub> O	
JL4028H12B	12	7~13.2	0.25	0.22	3	10000	0.460	16.23	0.617	15.68	46.3
JL4028M12B	12	7~13.2	0.20	0.18	2.4	8500	0.390	13.79	0.446	11.33	42.7
JL4028L12B	12	7~13.2	0.12	0.1	1.44	7000	0.322	11.36	0.320	7.68	38.5
JL4028U24B	24	18~26.4	0.25	0.2	6	13000	0.597	21.10	1.043	26.50	52
JL4028H24B	24	18~26.4	0.12	0.10	2.88	10000	0.460	16.23	0.617	15.68	46.3
JL4028M24B	24	18~26.4	0.1	0.09	2.4	8500	0.390	13.79	0.446	11.33	42.7
JL4028L24B	24	18~26.4	0.07	0.06	1.68	7000	0.322	11.36	0.302	7.68	38.5

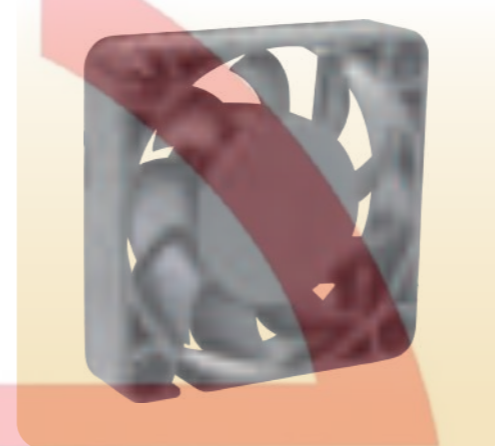

### DIMENSIONS DRAWING

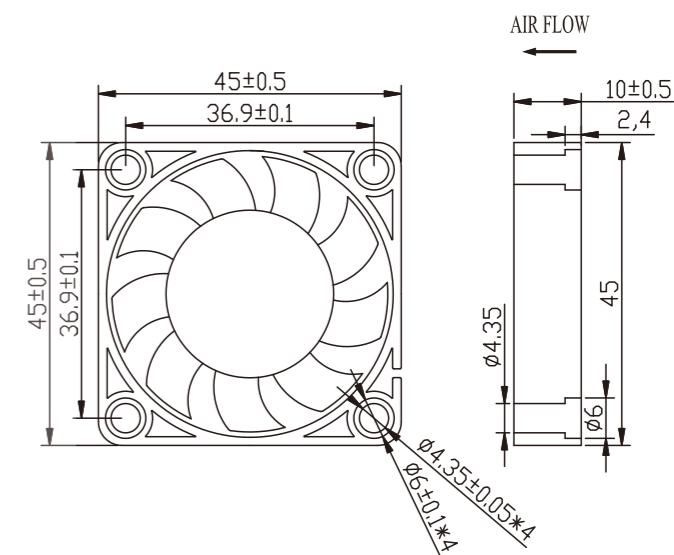

### P & Q CURVE (AT RATED VOLTAGE)

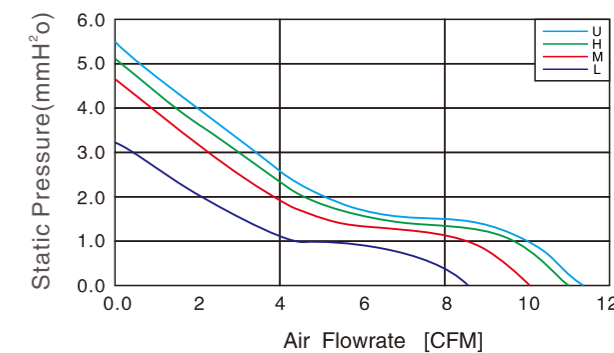

### DC AXIAL FAN 45\*45\*10MM SERIES

Material  
UL 1007 AWG # 26 OR Equivalent  
Red Wire:Positive (+)  
Black Wire:Negative (-)  
Yellow wire:FG or RD Signal

MODEL NO	RATED VOLTAGE V	OPERATING VOLTAGE V	RATED CURRENT A	ACTUAL CURRENT A	RATED POWER	RATED SPEED RPM (±10%)	MAX. AIR FLOW		MAX.STATIC AIR PRESSURE		NOISE LEVEL db(A)
							CMM	CFM	InH <sub>2</sub> O	mmH <sub>2</sub> O	
JL4510L05	5	3.6~6.8	0.14	0.12	0.7	5000	0.31	3.22	0.13	3.22	30.2
JL4510L12	12	6.0~13.5	0.07	0.05	0.84	5000	0.31	3.22	0.13	3.22	30.2
JL4510M05	5	3.6~6.8	0.18	0.16	0.9	6000	0.36	4.67	0.18	4.67	32.6
JL4510M12	12	6.0~13.5	0.08	0.06	0.96	6000	0.36	4.67	0.18	4.67	32.6
JL4015H05	5	3.6~6.8	0.27	0.25	1.35	6500	0.39	5.12	0.22	5.12	36.5
JL4015H12	12	6.0~13.5	0.1	0.08	1.2	6500	0.39	5.12	0.22	5.12	36.5
JL4015H12-HH	24	6.0~13.5	0.15	0.13	1.8	7000	0.41	5.51	0.24	5.51	38.4
JL4015H24-HH	24	18~26.5	0.08	0.06	1.92	7000	0.41	5.51	0.24	5.51	38.4

九 龙 电 机

AC Axial Fan  
AC轴流风机

AC All-Metal Axial Fan  
AC全金属轴流风扇

DC Axial Fan  
DC轴流风机

DC Centrifugal Fan  
DC离心风机

EC Axial Fan  
EC轴流风机

EC Centrifugal Fan  
EC离心风机

AC Centrifugal Fan  
AC离心风机

Fan Accessories  
风机配件



本样图仅供参考，具体规格以实物为准。  
This sample book is for reference only. Please refer to the specification for details.  
如需特殊电压也可根据需求提供。本公司保留技术更改权利。  
Special voltage may be provided according to the requirement. All technical modification rights reserved.



## DC AXIAL FAN 50\*50\*10MM SERIES

**Material**  
UL 1007 AWG # 28 OR Equivalent  
Red Wire: Positive (+)  
Black Wire: Negative (-)  
Yellow wire: FG or RD Signal

### DIMENSIONS DRAWING

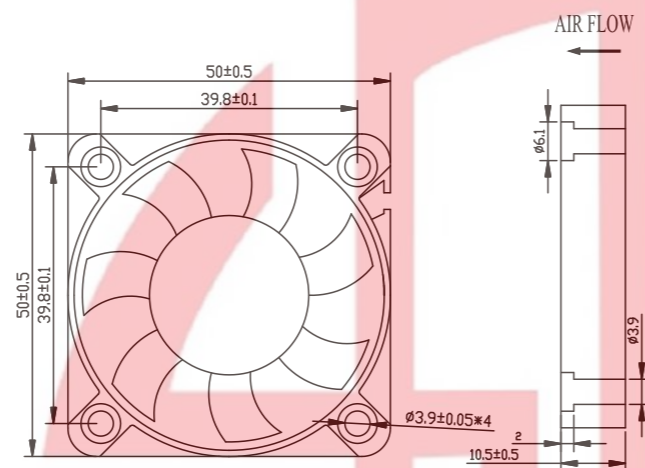

### P & Q CURVE (AT RATED VOLTAGE)

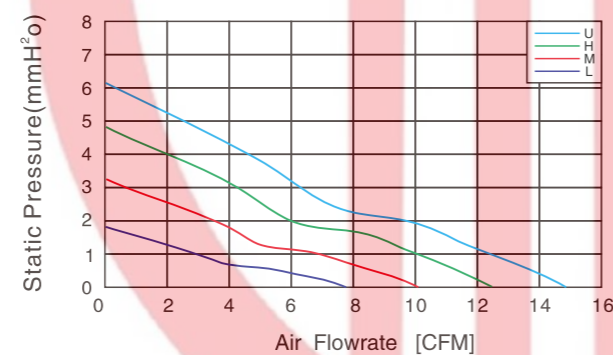

MODEL NO	RATED VOLTAGE V	OPERATING VOLTAGE V	RATED CURRENT A	ACTUAL CURRENT A	RATED POWER	RATED SPEED RPM (±10%)	MAX. AIR FLOW		MAX. STATIC AIR PRESSURE		NOISE LEVEL db(A)
							CMM	CFM	InH <sub>2</sub> O	mmH <sub>2</sub> O	
JL5010H05Y	5	4.5~5.5	0.22	0.2	1.1	5500	0.353	12.47	0.18	4.57	30.5
JL5010M05Y	5	4.5~5.5	0.18	0.16	0.9	4500	0.289	10.2	0.12	3.06	26.2
JL5010L05Y	5	4.5~5.5	0.12	0.1	0.6	3500	0.225	7.94	0.07	1.85	20.8
JL5010U12Y	12	9.5~13.2	0.22	0.2	2.64	6500	0.417	14.74	0.25	6.38	34.2
JL5010H12Y	12	9.5~13.2	0.12	0.09	1.44	5500	0.353	12.47	0.18	4.57	30.5
JL5010M12Y	12	9.5~13.2	0.09	0.08	1.08	4500	0.289	10.2	0.12	3.06	26.2
JL5010L12Y	12	9.5~13.2	0.07	0.06	0.84	3500	0.225	7.94	0.07	1.85	20.8

PS: Where Y can be S . B.

### DIMENSIONS DRAWING

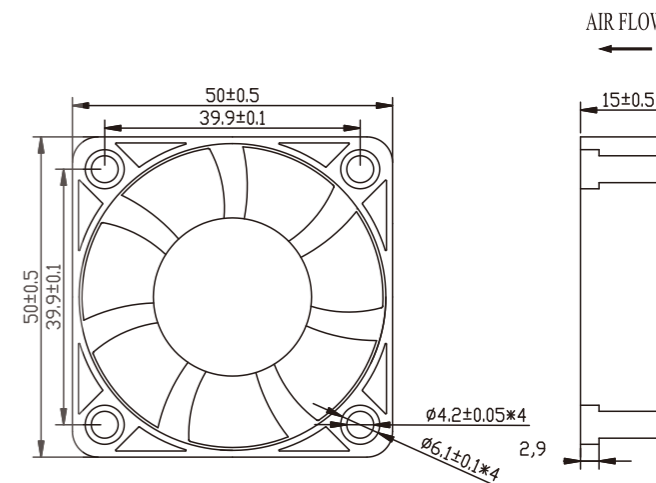

## DC AXIAL FAN 50\*50\*15MM SERIES

**Material**  
UL 1007 AWG # 26 OR Equivalent  
Red Wire: Positive (+)  
Black Wire: Negative (-)  
Yellow wire: FG or RD Signal

### P & Q CURVE (AT RATED VOLTAGE)

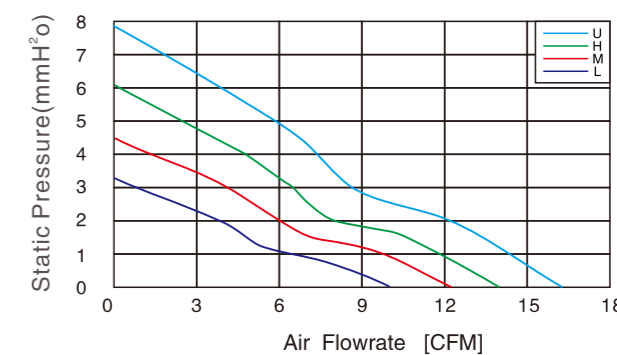

MODEL NO	RATED VOLTAGE V	OPERATING VOLTAGE V	RATED CURRENT A	ACTUAL CURRENT A	RATED POWER	RATED SPEED RPM (±10%)	MAX. AIR FLOW		MAX. STATIC AIR PRESSURE		NOISE LEVEL db(A)
							CMM	CFM	InH <sub>2</sub> O	mmH <sub>2</sub> O	
JL5015U12Y	12	7~13.2	0.19	0.17	2.28	6400	0.458	16.17	0.312	7.93	35.5
JL5015H12Y	12	7~13.2	0.15	0.13	1.8	5600	0.397	14.02	0.237	6.01	30.7
JL5015M12Y	12	7~13.2	0.13	0.11	1.56	4800	0.343	12.11	0.179	4.54	28.3
JL5015L12Y	12	7~13.2	0.1	0.08	1.2	4000	0.275	9.71	0.123	3.12	25.2
JL5015U12Y	24	14~13.2	0.1	0.09	2.4	6400	0.458	16.17	0.312	7.93	35.5
JL5015H12Y	24	14~13.2	0.09	0.08	2.16	5600	0.397	14.02	0.237	6.01	30.7
JL5015M12Y	24	14~13.2	0.07	0.06	1.68	4800	0.343	12.11	0.179	4.54	28.3
JL5015L12Y	24	14~13.2	0.07	0.05	1.44	4000	0.275	9.71	0.123	3.12	25.2

PS: Where Y can be S . B.

九 龙 电 机



JULONG MOTOR  
AC/DC FANS COOLING FANS



本样机仅供参考，具体以规格书为准。  
This sample book is for reference only, please refer to the specification for details.  
如需特殊电压也可根据规格书提供。本公司保留技术知识产权。  
Special voltage may be provided according to the requirement, although technical modification is reserved.

Http://www.xtgygs.cn



### DIMENSIONS DRAWING

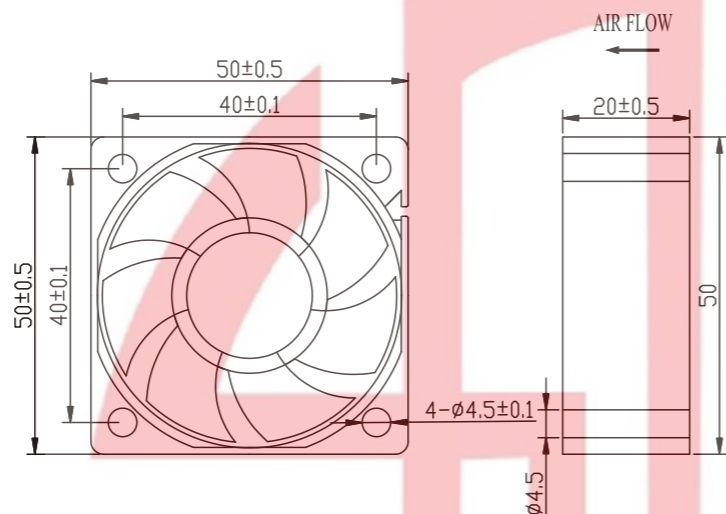

### DC AXIAL FAN 50\*50\*20MM SERIES

Material  
UL 1007 AWG # 24 OR Equivalent  
Red Wire: Positive (+)  
Black Wire: Negative (-)  
Yellow wire: FG or RD Signal

### P & Q CURVE (AT RATED VOLTAGE)

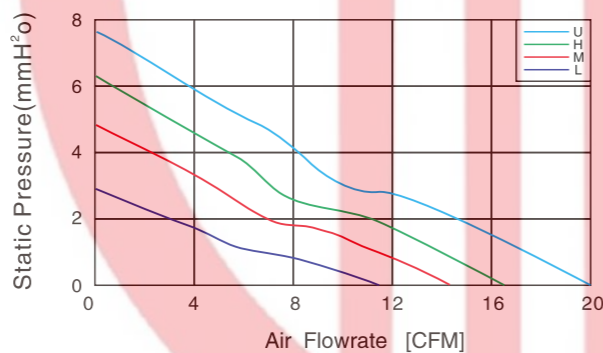

MODEL NO	RATED VOLTAGE V	OPERATING VOLTAGE V	RATED CURRENT A	ACTUAL CURRENT A	RATED POWER	RATED SPEED RPM (±10%)	MAX. AIR FLOW		MAX. STATIC AIR PRESSURE		NOISE LEVEL db(A)
							CMM	CFM	InH <sub>2</sub> O	mmH <sub>2</sub> O	
JL5020U12Y	12	7~13.2	0.22	0.2	2.64	7000	0.564	19.92	0.302	7.67	41.9
JL5020H12Y	12	7~13.2	0.18	0.16	2.16	6000	0.471	16.63	0.243	6.17	36.7
JL5020M12Y	12	7~13.2	0.14	0.12	1.68	5200	0.42	14.83	0.182	4.63	29.8
JL5020L12Y	12	7~13.2	0.1	0.09	1.2	4000	0.312	11.02	0.108	2.74	24.8
JL5020U24Y	24	14~26.4	0.14	0.12	3.36	7000	0.564	19.92	0.302	7.67	41.9
JL5020H24Y	24	14~26.4	0.1	0.09	2.4	6000	0.471	16.63	0.243	6.17	36.7
JL5020M24Y	24	14~26.4	0.08	0.09	1.92	5200	0.42	14.83	0.182	4.63	29.8
JL5020L24Y	24	14~26.4	0.07	0.06	1.68	4000	0.312	11.02	0.108	2.74	24.8

■ PS: Where Y can be S .B.

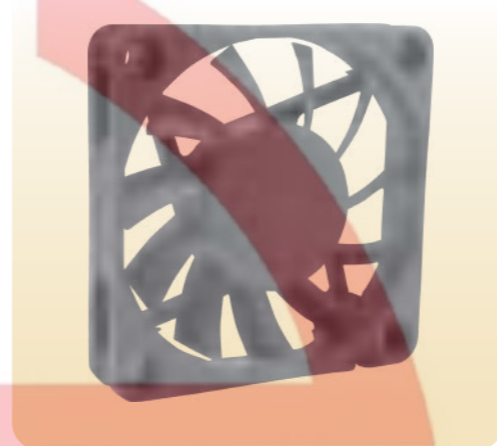

### DIMENSIONS DRAWING

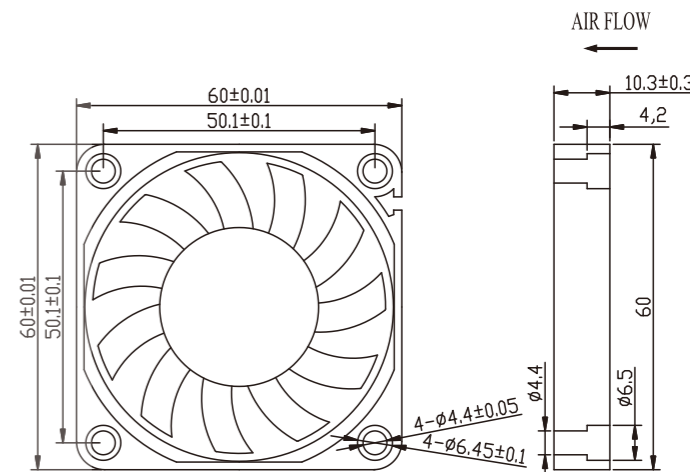

### DC AXIAL FAN 60\*60\*10MM SERIES

Material  
UL 1007 AWG # 28 OR Equivalent  
Red Wire: Positive (+)  
Black Wire: Negative (-)  
Yellow wire: FG or RD Signal

### P & Q CURVE (AT RATED VOLTAGE)

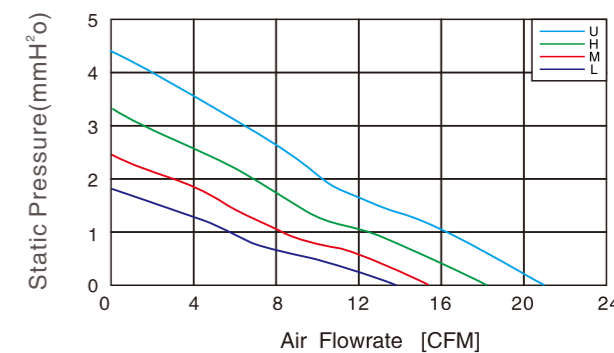

MODEL NO	RATED VOLTAGE V	OPERATING VOLTAGE V	RATED CURRENT A	ACTUAL CURRENT A	RATED POWER	RATED SPEED RPM (±10%)	MAX. AIR FLOW		MAX. STATIC AIR PRESSURE		NOISE LEVEL db(A)
							CMM	CFM	InH <sub>2</sub> O	mmH <sub>2</sub> O	
JL6010U12Y	12	7~13.2	0.28	0.26	3.36	4800	0.591	20.87	0.169	4.3	36.3
JL6010H12Y	12	7~13.2	0.2	0.17	2.4	4200	0.511	18.05	0.132	3.35	33.2
JL6010M12Y	12	7~13.2	0.14	0.12	1.68	3600	0.44	15.54	0.094	2.40	30.7
JL6010L12Y	12	7~13.2	0.1	0.09	1.2	2600	0.38	13.42	0.065	1.65	24.7
JL6010U24Y	24	18~26.4	0.15	0.14	3.6	4800	0.591	20.87	0.169	4.30	36.3
JL6010H24Y	24	18~26.4	0.12	0.11	2.88	4200	0.511	18.05	0.132	3.35	33.2
JL6010M24Y	24	18~26.4	0.08	0.09	1.92	3600	0.44	15.54	0.094	2.40	30.7
JL6010L24Y	24	18~26.4	0.06	0.05	1.44	2600	0.38	13.42	0.065	1.65	24.7

■ PS: Where Y can be S .B.

# 九 龙 电 机

AC Axial Fan  
AC轴流风机

AC All-Metal Axial Fan  
AC全金属轴流风扇

DC Axial Fan  
DC轴流风机

DC Centrifugal Fan  
DC离心风机

EC Axial Fan  
EC轴流风机

EC Centrifugal Fan  
EC离心风机

AC Centrifugal Fan  
AC离心风机

Fan Accessories  
风机配件



JULONG MOTOR  
AC/DC FANS COOLING FANS



UL  
E248719



本样品的制造型号仅供参考，具体以规格书为准。  
This sample book is for reference only. Please refer to the specification for details.  
如需特殊电压也可根据规格提供。本公司保留技术知识产权。  
Special voltage may be provided according to the requirement, although technical modification is reserved.

Http://www.xtgygs.cn



### DIMENSIONS DRAWING

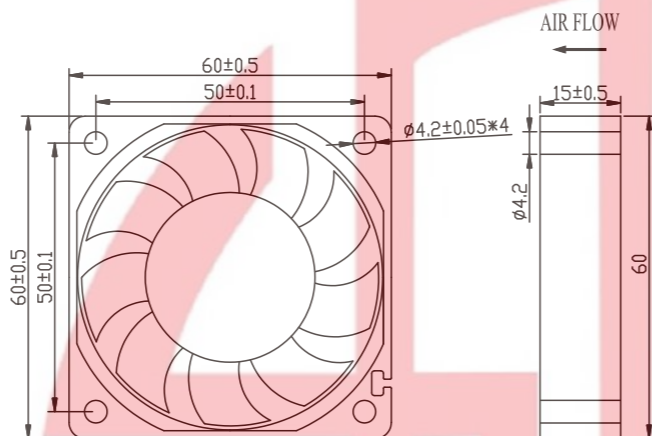

### DC AXIAL FAN 60\*60\*15MM 2 SERIES

Material  
UL 1007 AWG # 28 OR Equivalent  
Red Wire: Positive (+)  
Black Wire: Negative (-)  
Yellow wire: FG or RD Signal

### P & Q CURVE (AT RATED VOLTAGE)

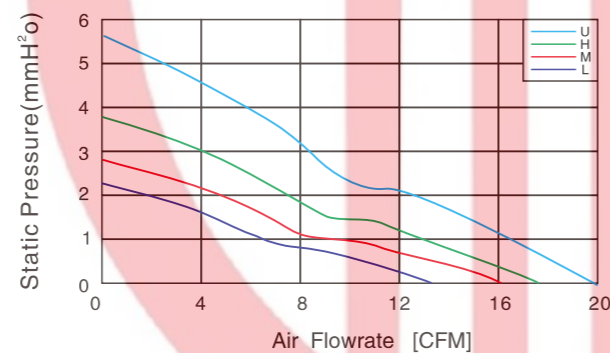

MODEL NO	RATED VOLTAGE V	OPERATING VOLTAGE V	RATED CURRENT A	ACTUAL CURRENT A	RATED POWER	RATED SPEED RPM (±10%)	MAX. AIR FLOW		MAX. STATIC AIR PRESSURE		NOISE LEVEL db(A)
							CMM	CFM	InH2O	mmH2O	
JL6015U12Y	12	7~13.2	0.2	0.18	2.4	5000	0.64	22.77	0.24	6.1	35.9
JL6015H12Y	12	7~13.2	0.15	0.13	1.8	4200	0.541	19.12	0.169	4.3	32.1
JL6015M12Y	12	7~13.2	0.11	0.09	1.3	3500	0.45	15.9	0.115	2.92	28.2
JL6015L12Y	12	7~13.2	0.08	0.07	1.0	3000	0.387	13.67	0.089	2.26	24.7
JL6015U24Y	24	14~26.4	0.14	0.12	3.4	5000	0.64	22.77	0.24	6.1	35.9
JL6015H24Y	24	14~26.4	0.1	0.09	2.4	4200	0.541	19.12	0.169	4.3	32.1
JL6015M24Y	24	14~26.4	0.07	0.06	1.7	3500	0.45	15.9	0.115	2.92	28.2
JL6015L24Y	24	14~26.4	0.05	0.04	1.2	3000	0.387	13.67	0.089	2.26	24.7

■ PS: Where Y can be S .B.



### DIMENSIONS DRAWING

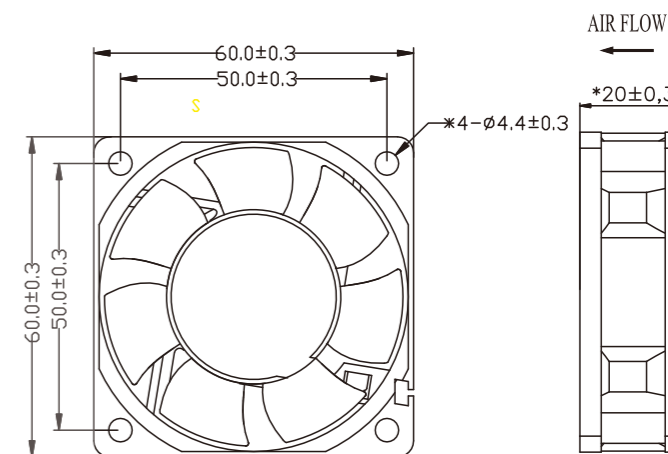

### DC AXIAL FAN 60\*60\*20MM SERIES

Material  
UL 1007 AWG # 24 OR Equivalent  
Red Wire: Positive (+)  
Black Wire: Negative (-)  
Yellow wire: FG or RD Signal

### P & Q CURVE (AT RATED VOLTAGE)

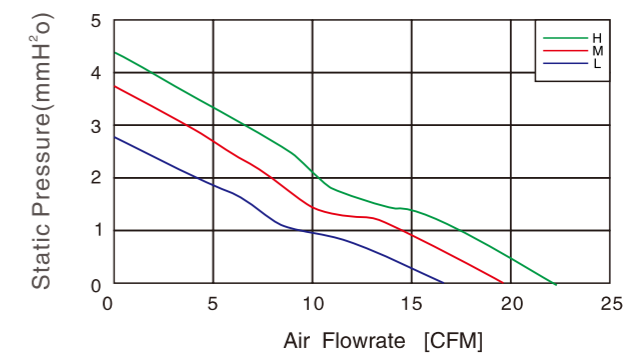

MODEL NO	RATED VOLTAGE V	OPERATING VOLTAGE V	RATED CURRENT A	ACTUAL CURRENT A	RATED POWER	RATED SPEED RPM (±10%)	MAX. AIR FLOW		MAX. STATIC AIR PRESSURE		NOISE LEVEL db(A)
							CMM	CFM	InH2O	mmH2O	
JL6020H12Y	12	7~13.2	0.2	0.18	2.4	4500	0.647	22.849	0.232	5.893	34.2
JL6020M12Y	12	7~13.2	0.17	0.15	2.04	4000	0.574	20.271	0.181	4.597	32.6
JL6020L12Y	12	7~13.2	0.13	0.12	1.56	3500	0.507	17.905	0.143	3.632	29.7
JL6020H24Y	24	14~26.4	0.13	0.11	3.12	4500	0.647	22.849	0.232	5.893	34.2
JL6020M24Y	24	18~26.4	0.1	0.09	2.4	4000	0.574	20.271	0.181	4.597	32.6
JL6020L24Y	24	18~26.4	0.08	0.07	1.92	3500	0.507	17.905	0.143	3.632	29.7

■ PS: Where Y can be S .B.

# 九 龙 电 机



JULONG MOTOR  
AC/DC FANS COOLING FANS



本材料均经型式试验合格并符合标准。  
This sample book is for reference only. Please refer to the specification for details.  
如需特殊电压也可根据需求提供。本公司保留技术知识产权。  
Special voltage may be provided flexibly according to the requirement. All technical modification rights reserved.

Http://www.xtgygs.cn



### DIMENSIONS DRAWING

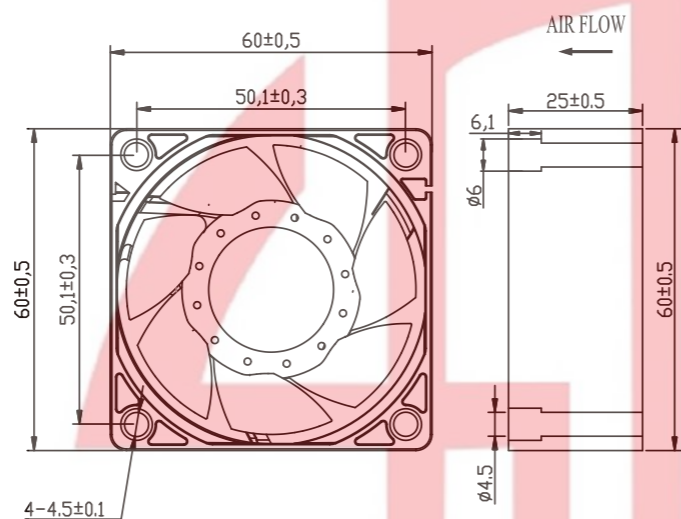

### P & Q CURVE (AT RATED VOLTAGE)

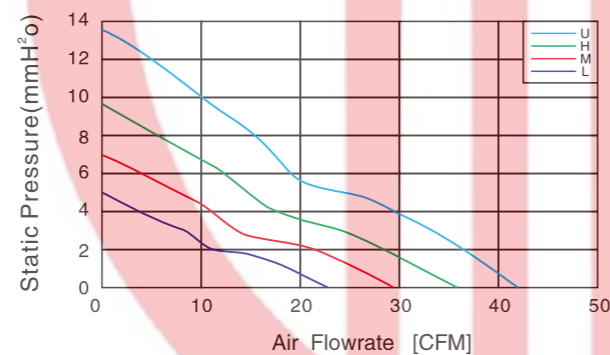

## DC AXIAL FAN 60\*60\*25MM 2 SERIES

Material  
UL 1007 AWG # 24 OR Equivalent  
Red Wire:Positive (+)  
Black Wire:Negative (-)  
Yellow wire:FG or RD Signal

MODEL NO	RATED VOLTAGE V	OPERATING VOLTAGE V	RATED CURRENT A	ACTUAL CURRENT A	RATED POWER	RATED SPEED RPM (±10%)	MAX. AIR FLOW		MAX.STATIC AIR PRESSURE		NOISE LEVEL db(A)
							CMM	CFM	InH2O	mmH2O	
JL6025U12B	12	7~13.2	0.6	0.54	7.2	7200	1.226	43.28	0.681	17.3	47.8
JL6025H12B	12	7~13.2	0.3	0.27	3.6	6000	1.021	36.06	0.473	12.01	43.9
JL6025M12Y	12	7~13.2	0.24	0.21	2.88	5000	0.851	30.05	0.263	8.34	40.0
JL6025L12Y	12	7~13.2	0.2	0.18	2.4	4200	0.715	25.25	0.189	5.89	35.7
JL6025U24B	24	14~26.4	0.3	0.28	7.2	7200	1.226	43.28	0.681	17.3	47.8
JL6025H24B	24	14~26.4	0.2	0.18	4.8	6000	1.021	36.06	0.473	12.01	43.9
JL6025M24Y	24	14~26.4	0.14	0.12	3.36	5000	0.851	30.05	0.263	8.34	40.0
JL6025L24Y	24	14~26.4	0.1	0.09	2.4	4200	0.715	25.25	0.189	5.89	35.7
JL6025U48B	48	36~52.8	0.18	0.16	8.64	7200	1.226	43.28	0.681	17.3	47.8
JL6025H24B	48	36~52.8	0.12	0.1	5.76	6000	1.021	36.06	0.473	12.01	43.9
JL6025M24Y	48	36~52.8	0.09	0.08	4.32	5000	0.851	30.05	0.263	8.34	40.0
JL6025L24Y	48	36~52.8	0.06	0.05	2.88	4200	0.715	25.25	0.189	5.89	35.7

PS:Where Y can be S .B.



### DIMENSIONS DRAWING

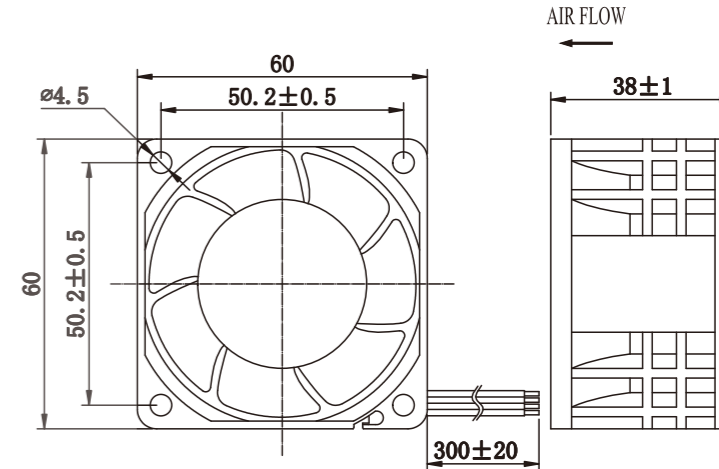

## DC AXIAL FAN 60\*60\*38MM SERIES

Material  
UL 1007 AWG # 24 OR Equivalent  
Red Wire:Positive (+)  
Black Wire:Negative (-)  
Yellow wire:FG or RD Signal

### P & Q CURVE (AT RATED VOLTAGE)

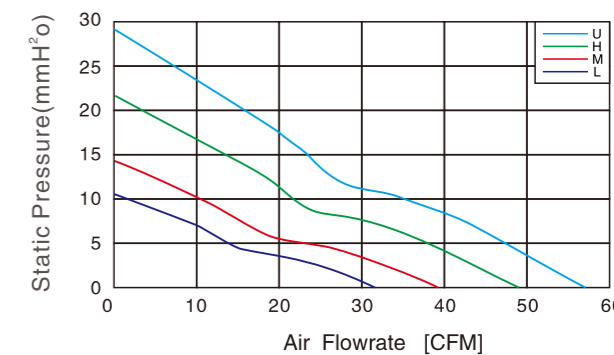

MODEL NO	RATED VOLTAGE V	OPERATING VOLTAGE V	RATED CURRENT A	ACTUAL CURRENT A	RATED POWER	RATED SPEED RPM (±10%)	MAX. AIR FLOW		MAX.STATIC AIR PRESSURE		NOISE LEVEL db(A)
							CMM	CFM	InH2O	mmH2O	
JL6038H12B	12	6~13.2	0.85	0.78	10.2	8500	1.36	48.20	0.93	23.5	53.4
JL6038M12B	12	6~13.2	0.5	0.45	6	7000	1.11	39.10	0.63	15.96	47.9
JL6038L12B	12	6~13.2	0.40	0.35	4.8	6000	0.95	33.51	0.46	11.72	44.3
JL6038U24B	24	12~26.4	0.65	0.57	15.6	10000	1.60	56.68	1.28	32.56	57.9
JL6038H24B	24	12~26.4	0.45	0.4	10.8	8500	1.36	48.20	0.93	23.5	53.4
JL6038M24B	24	12~26.4	0.3	0.25	7.2	7000	1.11	39.10	0.63	15.96	47.9
JL6038L24B	24	12~26.4	0.25	0.2	6	6000	0.95	33.51	0.46	11.72	44.3
JL6038U48B	48	36~52.8	0.35	0.3	16.8	10000	1.60	56.68	1.28	32.56	57.9
JL6038H48B	48	36~52.8	0.28	0.22	13.44	8500	1.36	48.20	0.93	23.5	53.4
JL6038M48B	48	36~52.8	0.18	0.15	8.64	7000	1.11	39.10	0.63	15.96	47.9
JL6038L48B	48	36~52.8	0.15	0.12	7.2	6000	0.95	33.51	0.46	11.72	44.3

PS:Where Y can be S .B.

AC Axial Fan  
AC轴流风机

AC All-Metal Axial Fan  
AC全金属轴流风扇

DC Axial Fan  
DC轴流风机

DC Centrifugal Fan  
DC离心风机

EC Axial Fan  
EC轴流风机

EC Centrifugal Fan  
EC离心风机

AC Centrifugal Fan  
AC离心风机

Fan Accessories  
风机配件



JILONG MOTOR  
AC/DC FANS COOLING FANS



UL  
E248719



本样机仅供参考，具体以规格书为准。  
This sample book is for reference only, please refer to the specification for details.  
如需特殊电压也可根据规格书提供。本公司保留技术更改权利。  
Special voltage may be provided flexibly according to the enquiry, although technical modification right reserved.

Http://www.xtgygs.cn



DIMENSIONS DRAWING

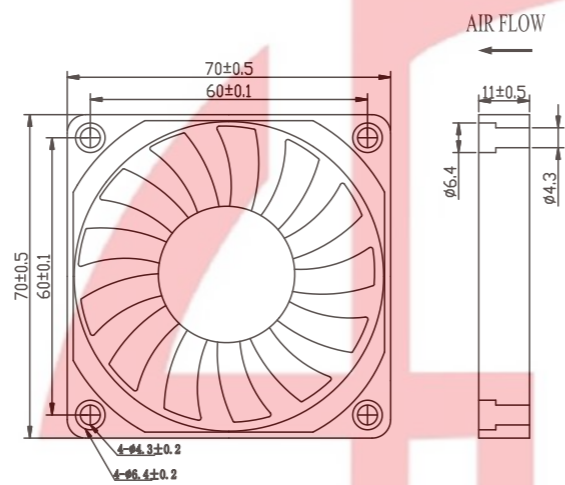

P & Q CURVE (AT RATED VOLTAGE)

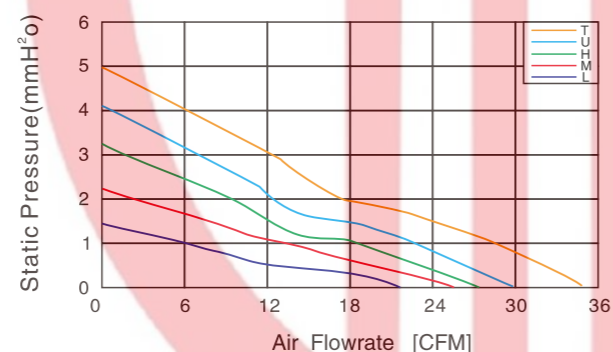

DC AXIAL FAN  
70\*70\*10MM SERIES

Material  
UL 1007 AWG # 28 OR Equivalent  
Red Wire:Positive (+)  
Black Wire:Negative (-)  
Yellow wire:FG or RD Signal

MODEL NO	RATED VOLTAGE V	OPERATING VOLTAGE V	RATED CURRENT A	ACTUAL CURRENT A	RATED POWER	RATED SPEED RPM (±10%)	MAX. AIR FLOW		MAX.STATIC AIR PRESSURE		NOISE LEVEL db(A)
							CMM	CFM	InH2O	mmH2O	
JL7010T12Y	12	7~13.2	0.36	0.33	4.32	5000	0.972	34.33	0.197	5.00	40.7
JL7010U12Y	12	7~13.2	0.28	0.25	3.36	4400	0.831	29.35	0.159	4.04	37.9
JL7010H12Y	12	7~13.2	0.23	0.21	2.76	3800	0.81	28.61	0.121	3.07	33.6
JL7010M12Y	12	7~13.2	0.16	0.14	1.92	3200	0.768	27.12	0.089	2.26	30.1
JL7010L12Y	12	7~13.2	0.09	0.08	1.08	2600	0.636	22.46	0.059	1.50	23.8
JL7010T24Y	24	18~26.4	0.26	0.23	6.24	5000	0.972	34.33	0.197	5.00	40.7
JL7010U24Y	24	14~26.4	0.2	0.18	4.8	4400	0.831	29.35	0.159	4.04	37.9
JL7010H24Y	24	18~26.4	0.17	0.15	4.08	3800	0.81	28.61	0.121	3.07	33.6
JL7010M24Y	24	18~26.4	0.12	0.11	2.88	3200	0.768	27.12	0.089	2.26	30.1
JL7010L24Y	24	14~26.4	0.08	0.07	1.92	2600	0.636	22.46	0.059	1.50	23.8

PS:Where Y can be S .B.



DIMENSIONS DRAWING

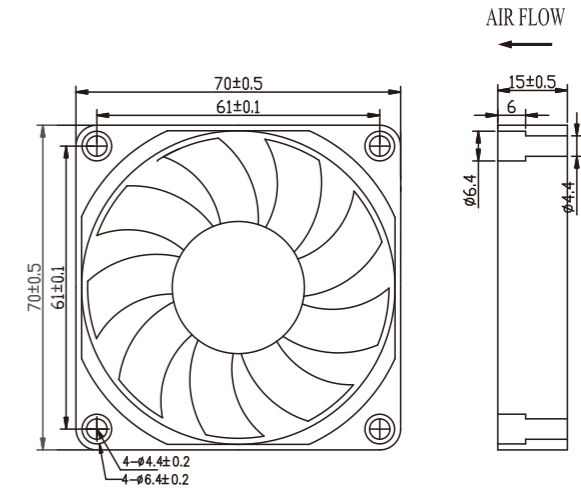

P & Q CURVE (AT RATED VOLTAGE)

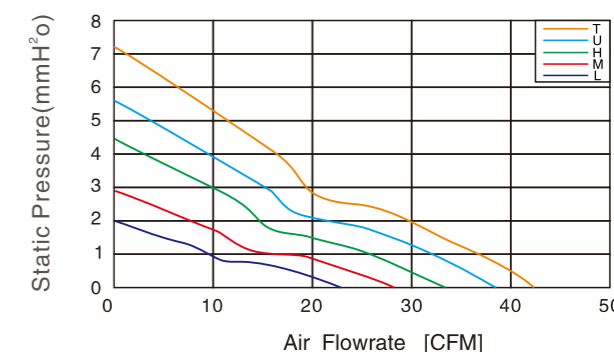

DC AXIAL FAN  
70\*70\*15MM SERIES

Material  
UL 1007 AWG # 26 OR Equivalent  
Red Wire:Positive (+)  
Black Wire:Negative (-)  
Yellow wire:FG or RD Signal

MODEL NO	RATED VOLTAGE V	OPERATING VOLTAGE V	RATED CURRENT A	ACTUAL CURRENT A	RATED POWER	RATED SPEED RPM (±10%)	MAX. AIR FLOW		MAX.STATIC AIR PRESSURE		NOISE LEVEL db(A)
							CMM	CFM	InH2O	mmH2O	
JL7015T12Y	12	7~13.2	0.55	0.5	6.6	5000	1.23	43.28	0.281	7.13	40.4
JL7015U12Y	12	7~13.2	0.42	0.38	5.04	4400	1.09	36.06	0.217	5.52	37.6
JL7015H12Y	12	7~13.2	0.3	0.27	3.6	3800	0.94	30.05	0.162	4.12	33.9
JL7015M12Y	12	7~13.2	0.24	0.21	2.88	3200	0.79	25.25	0.115	2.92	27.5
JL7015L12Y	12	14~26.4	0.15	0.13	1.8	2600	0.64	43.28	0.076	1.93	22.8
JL7015T24Y	24	18~26.4	0.29	0.26	6.96	5000	1.23	36.06	0.281	7.13	40.4
JL7015U24Y	24	18~26.4	0.22	0.2	5.28	4400	1.09	30.05	0.217	5.52	37.6
JL7015H24Y	24	18~26.4	0.16	0.14	3.84	3800	0.94	25.25	0.162	4.12	33.9
JL7015M24Y	24	18~26.4	0.12	0.11	2.88	3200	0.79	43.28	0.115	2.92	27.5
JL7015L24Y	24	18~26.4	0.07	0.06	1.68	2600	0.64	36.06	0.076	1.93	22.8

PS:Where Y can be S .B.

AC Axial Fan  
AC轴流风机

AC All-Metal Axial Fan  
AC全金属轴流风扇

DC Axial Fan  
DC轴流风机

DC Centrifugal Fan  
DC离心风机

EC Axial Fan  
EC轴流风机

EC Centrifugal Fan  
EC离心风机

AC Centrifugal Fan  
AC离心风机

Fan Accessories  
风机配件



JILONG MOTOR  
AC/DC FANS COOLING FANS



本样册仅供参考，具体以规格书为准。  
This sample book is for reference only. Please refer to the specification for details.  
如需特殊电压也可根据需求提供。本公司保留技术更改权利。  
Special voltage may be provided according to the requirement. All technical modification rights reserved.

Http://www.xtgygs.cn

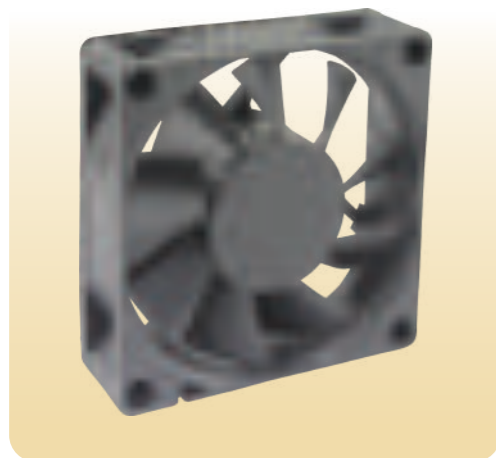

### DIMENSIONS DRAWING

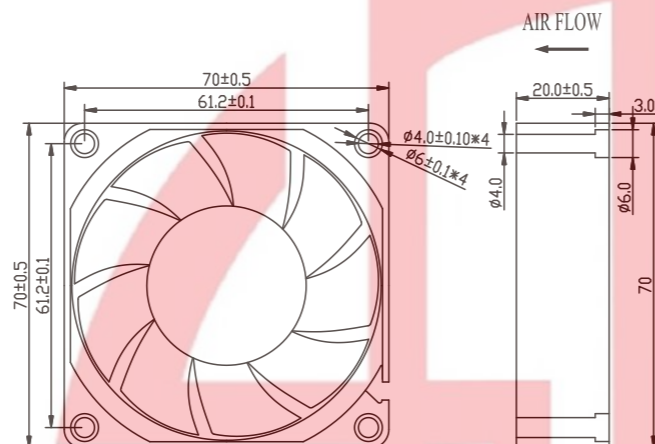

### P & Q CURVE (AT RATED VOLTAGE)

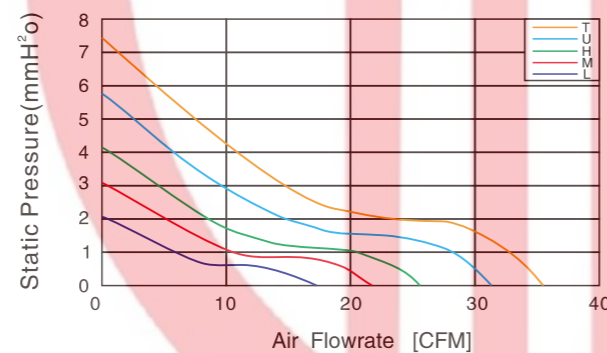

### DC AXIAL FAN 70\*70\*20MM SERIES

Material  
UL 1007 AWG # 26 OR Equivalent  
Red Wire: Positive (+)  
Black Wire: Negative (-)  
Yellow wire: FG or RD Signal

MODEL NO	RATED VOLTAGE V	OPERATING VOLTAGE V	RATED CURRENT A	ACTUAL CURRENT A	RATED POWER	RATED SPEED RPM (±10%)	MAX. AIR FLOW		MAX. STATIC AIR PRESSURE		NOISE LEVEL db(A)
							CMM	CFM	InH <sub>2</sub> O	mmH <sub>2</sub> O	
JL7020L12	12	6.0~13.5	0.12	0.10	1.44	2500	0.489	17.29	0.082	2.068	36.2
JL7020L24	24	18~26.5	0.08	0.06	1.92	2500	0.489	17.29	0.082	2.068	36.2
JL7020M12	12	6.0~13.5	0.2	0.18	2.4	3000	0.619	21.89	0.122	3.101	31
JL7020M24	24	18~26.5	0.11	0.09	2.64	3000	0.619	21.89	0.122	3.101	31
JL7020H12	12	6.0~13.5	0.24	0.22	2.88	3500	0.723	25.54	0.163	4.135	35.2
JL7020H24	24	18~26.5	0.13	0.11	3.12	3500	0.723	25.54	0.163	4.135	35.2
JL7020H12-HH	12	6.0~13.5	0.25	0.23	3	4000	0.888	31.38	0.229	5.814	37.1
JL7020H24-HH	24	18~26.5	0.17	0.15	4.08	4000	0.888	31.38	0.229	5.814	37.1
JL7020H12-VH	12	6.0~13.5	0.35	0.33	4.2	4500	1.004	35.48	0.551	7.494	39.4
JL7020H24-VH	24	18~26.5	0.22	0.20	5.28	4500	1.004	35.48	0.551	7.494	39.4



### DIMENSIONS DRAWING

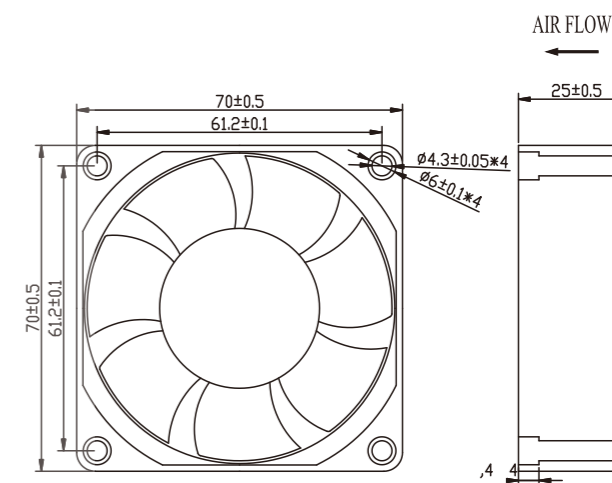

### P & Q CURVE (AT RATED VOLTAGE)

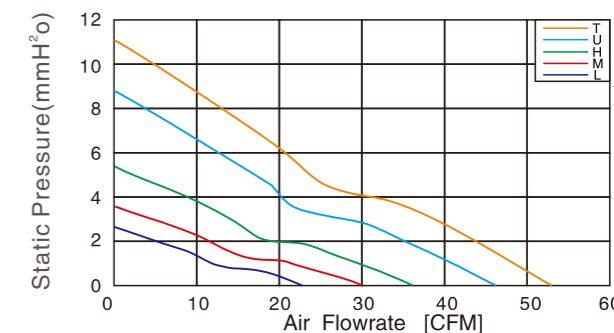

### DC AXIAL FAN 70\*70\*25MM SERIES

Material  
UL 1007 AWG # 24 OR Equivalent  
Red Wire: Positive (+)  
Black Wire: Negative (-)  
Yellow wire: FG or RD Signal

MODEL NO	RATED VOLTAGE V	OPERATING VOLTAGE V	RATED CURRENT A	ACTUAL CURRENT A	RATED POWER	RATED SPEED RPM (±10%)	MAX. AIR FLOW		MAX. STATIC AIR PRESSURE		NOISE LEVEL db(A)
							CMM	CFM	InH <sub>2</sub> O	mmH <sub>2</sub> O	
JL7025T12Y	12	6~13.2	0.6	0.55	7.2	5600	1.498	52.9	0.448	11.39	47.9
JL7025U12Y	12	6~13.2	0.4	0.35	4.8	4800	1.283	45.3	0.330	8.37	44.5
JL7025H12Y	12	6~13.2	0.28	0.25	3.36	3800	1.017	35.9	0.207	5.25	39.5
JL7025M12Y	12	6~13.2	0.17	0.15	2.04	3200	0.856	30.24	0.146	3.72	35.7
JL7025L12Y	12	6~13.2	0.07	0.06	0.84	2600	0.697	24.6	0.097	2.46	31.2
JL7025T24Y	24	12~26.4	0.3	0.28	7.2	5600	1.498	52.9	0.448	11.39	47.9
JL7025U24Y	24	12~26.4	0.2	0.18	4.8	4800	1.283	45.3	0.330	8.37	44.5
JL7025H24Y	24	12~26.4	0.15	0.13	3.6	3800	1.017	35.9	0.207	5.25	39.5
JL7025M24Y	24	12~26.4	0.09	0.08	2.16	3200	0.856	30.24	0.146	3.72	35.7
JL7025L24Y	24	12~26.4	0.04	0.03	0.96	2600	0.697	24.6	0.097	2.46	31.2
JL7025T48Y	48	36~52.8	0.15	0.14	7.2	5600	1.498	52.9	0.448	11.39	47.9
JL7025U48Y	48	36~52.8	0.1	0.09	4.8	4800	1.283	45.3	0.330	8.37	44.5
JL7025H48Y	48	36~52.8	0.08	0.07	3.84	3800	1.017	35.9	0.207	5.25	39.5
JL7025M48Y	48	36~52.8	0.05	0.04	2.4	3200	0.856	30.24	0.146	3.72	35.7
JL7025L48Y	48	36~52.8	0.03	0.02	1.44	2600	0.697	24.6	0.097	2.46	31.2

PS: Where Y can be S, B.



JULONG MOTOR  
AC/DC FANS COOLING FANS



本样图仅供参考，具体以实物为准。  
This sample book is for reference only. Please refer to the specification for details.  
如需特殊电压也可根据需求提供。本公司保留技术知识产权。  
Special voltage may be provided flexibly according to the requirement. All technical modification rights reserved.

Http://www.xtgygs.cn

### DIMENSIONS DRAWING

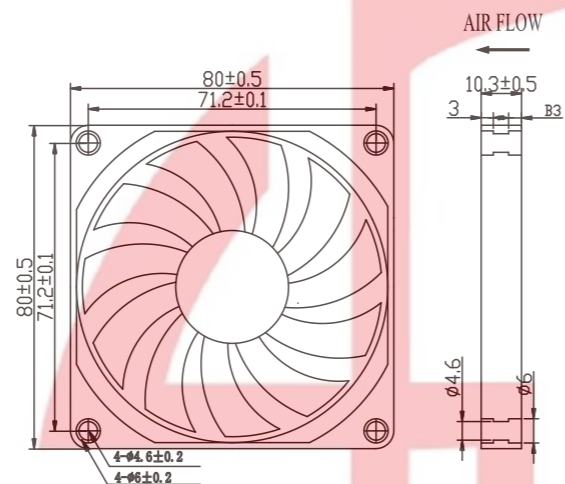

### P & Q CURVE (AT RATED VOLTAGE)

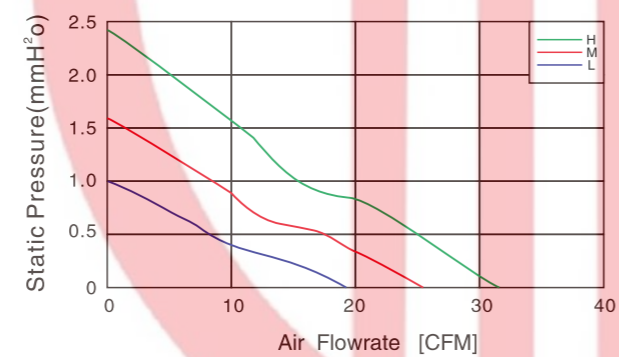

### DC AXIAL FAN 80\*80\*10MM SERIES

Material  
UL 1007 AWG # 28 OR Equivalent  
Red Wire:Positive (+)  
Black Wire:Negative (-)  
Yellow wire:FG or RD Signal

MODEL NO	RATED VOLTAGE V	OPERATING VOLTAGE V	RATED CURRENT A	ACTUAL CURRENT A	RATED POWER	RATED SPEED RPM (±10%)	MAX. AIR FLOW		MAX.STATIC AIR PRESSURE		NOISE LEVEL db(A)
							CMM	CFM	InH2O	mmH2O	
JL8010H12Y	12	7~13.2	0.18	0.16	2.16	3000	0.86	30.5	0.1	2.42	30.2
JL8010M12Y	12	7~13.2	0.15	0.13	1.8	2500	0.71	25.24	0.06	1.54	26.1
JL8010L12Y	12	7~13.2	0.12	0.1	1.44	2000	0.55	19.51	0.04	0.96	19.8

■ PS:Where Y can be S .B.

### DIMENSIONS DRAWING

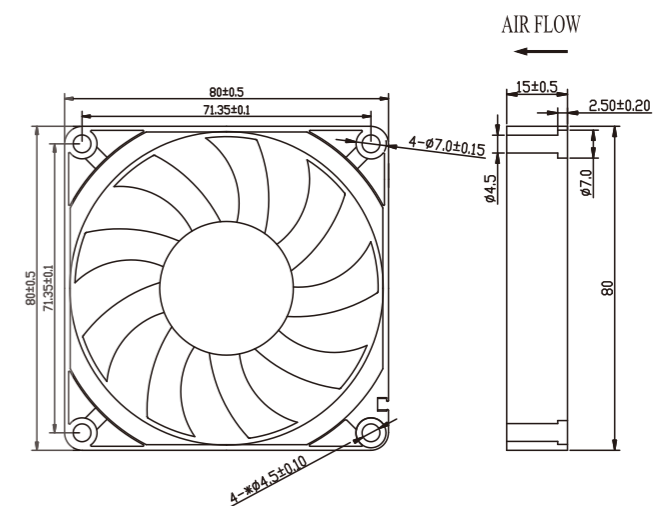
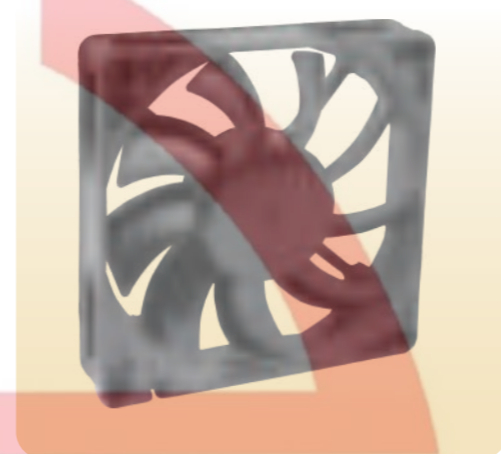

### DC AXIAL FAN 80\*80\*15MM SERIES

Material  
UL 1007 AWG # 26 OR Equivalent  
Red Wire:Positive (+)  
Black Wire:Negative (-)  
Yellow wire:FG or RD Signal

MODEL NO	RATED VOLTAGE V	OPERATING VOLTAGE V	RATED CURRENT A	ACTUAL CURRENT A	RATED POWER	RATED SPEED RPM (±10%)	MAX. AIR FLOW		MAX.STATIC AIR PRESSURE		NOISE LEVEL db(A)
							CMM	CFM	InH2O	mmH2O	
JL8015H12Y	12	7~13.2	0.24	0.21	2.88	3000	0.929	32.8	0.1	2.54	29.7
JL8015M12Y	12	7~13.2	0.18	0.16	2.16	2500	0.777	27.43	0.074	1.89	24.3
JL8015L12Y	12	7~13.2	0.1	0.09	1.2	2000	0.605	21.36	0.048	1.21	20.4
JL8015H24Y	24	14~26.4	0.09	0.08	2.16	3000	0.929	32.8	0.1	2.54	29.7
JL8015M24Y	24	14~26.4	0.08	0.06	1.92	2500	0.777	27.43	0.074	1.89	24.3
JL8015L24Y	24	14~26.4	0.05	0.04	1.2	2000	0.605	21.36	0.048	1.21	20.4

■ PS:Where Y can be S .B.

# 九 龙 电 机

AC Axial Fan  
AC轴流风机

AC All-Metal Axial Fan  
AC全金属轴流风扇

DC Axial Fan  
DC轴流风机

DC Centrifugal Fan  
DC离心风机

EC Axial Fan  
EC轴流风机

EC Centrifugal Fan  
EC离心风机

AC Centrifugal Fan  
AC离心风机

Fan Accessories  
风机配件



JILONG MOTOR  
AC/DC FANS COOLING FANS



UL 1007  
E248719



本样机仅供参考，具体规格以实物为准。  
This sample book is for reference only. Please refer to the specification for details.  
如需特殊电压也可特别定制提供。本公司保留技术更改权利。  
Special voltage may be provided, necessary according to the requirement. All technical modification rights reserved.

Http://www.xtgygs.cn



### DIMENSIONS DRAWING

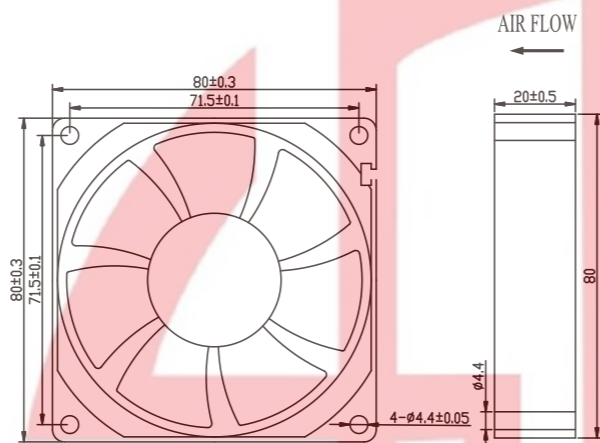

### DC AXIAL FAN 80\*80\*20MM SERIES

Material  
UL 1007 AWG # 24 OR Equivalent  
Red Wire: Positive (+)  
Black Wire: Negative (-)  
Yellow wire: FG or RD Signal

### P & Q CURVE (AT RATED VOLTAGE)

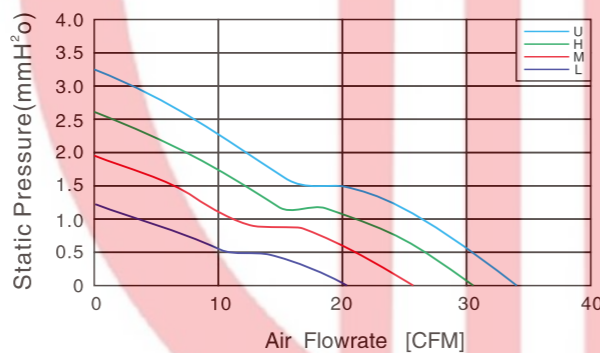

MODEL NO	RATED VOLTAGE V	OPERATING VOLTAGE V	RATED CURRENT A	ACTUAL CURRENT A	RATED POWER	RATED SPEED RPM (±10%)	MAX. AIR FLOW		MAX. STATIC AIR PRESSURE		NOISE LEVEL db(A)
							CMM	CFM	InH <sub>2</sub> O	mmH <sub>2</sub> O	
JL8020U12Y	12	6~13.2	0.34	0.3	4.08	3600	0.949	33.52	0.129	3.27	36.4
JL8020H12Y	12	6~13.2	0.24	0.21	2.88	3000	0.875	30.9	0.102	2.59	31.9
JL8020M12Y	12	6~13.2	0.15	0.13	1.8	2500	0.747	26.37	0.076	1.92	25
JL8020L12Y	12	6~13.2	0.12	0.1	1.44	2000	0.801	20.6	0.039	1.33	21.5

■ PS: Where Y can be S . B.

# 九 龙



### DC FAN 80 \* 80 \* 25MM SERIES

Material  
UL 1007 AWG # 24 OR Equivalent  
Red Wire: Positive (+)  
Black Wire: Negative (-)  
Yellow wire: FG or RD Signal

### DIMENSIONS DRAWING

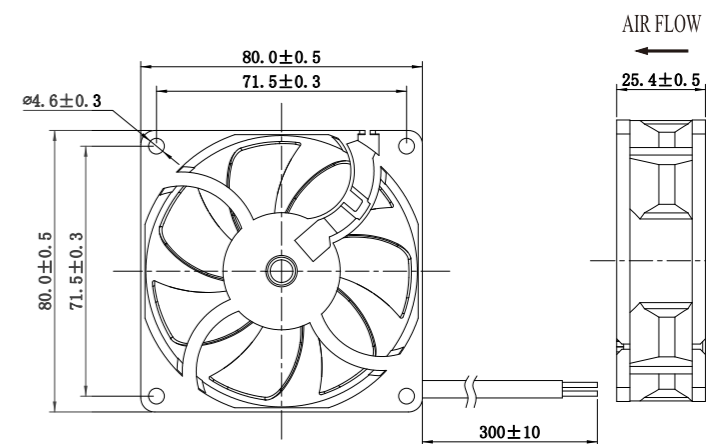

### P & Q CURVE (AT RATED VOLTAGE)

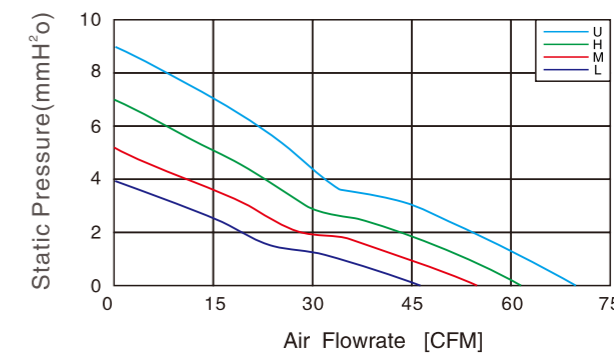

MODEL NO	RATED VOLTAGE V	OPERATING VOLTAGE V	RATED CURRENT A	ACTUAL CURRENT A	RATED POWER	RATED SPEED RPM (±10%)	MAX. AIR FLOW		MAX. STATIC AIR PRESSURE		NOISE LEVEL db(A)
							CMM	CFM	InH <sub>2</sub> O	mmH <sub>2</sub> O	
JL8025H12B	12	6~13.2	0.5	0.45	6	4000	1.73	61.18	0.274	6.96	39.7
JL8025M12Y	12	6~13.2	0.35	0.29	4.2	3500	1.51	53.50	0.210	5.33	37.1
JL8025L12Y	12	6~13.2	0.25	0.21	3	3000	1.30	45.90	0.154	3.92	33.8
JL8025U24B	24	12~26.4	0.3	0.25	7.2	4500	1.95	68.83	0.347	8.81	42.6
JL8025H24Y	24	12~26.4	0.25	0.23	6	4000	1.73	61.18	0.274	6.96	39.7
JL8025M24Y	24	12~26.4	0.2	0.18	4.8	3500	1.51	53.50	0.210	5.33	37.1
JL8025L24Y	24	12~26.4	0.15	0.13	3.6	3000	1.30	45.90	0.154	3.92	33.8
JL8025U48B	48	24~52.8	0.27	0.25	12.96	4500	1.95	68.83	0.347	8.81	42.6
JL8025H48Y	48	24~52.8	0.2	0.18	9.6	4000	1.73	61.18	0.274	6.96	39.7
JL8025M48Y	48	24~52.8	0.13	0.12	6.24	3500	1.51	53.50	0.210	5.33	37.1
JL8025L48Y	48	24~52.8	0.09	0.08	4.32	3000	1.30	45.90	0.154	3.92	33.8

■ PS: Where Y can be S . B.

# 电 机

AC Axial Fan  
AC轴流风机

AC All-Metal Axial Fan  
AC全金属轴流风扇

DC Axial Fan  
DC轴流风机

DC Centrifugal Fan  
DC离心风机

EC Axial Fan  
EC轴流风机

EC Centrifugal Fan  
EC离心风机

AC Centrifugal Fan  
AC离心风机

Fan Accessories  
风机配件



JULONG MOTOR  
AC/DC FANS COOLING FANS



本样机仅供参考，具体规格以规格书为准。  
This sample book is for reference only. Please refer to the specification for details.  
如需特殊电压也可根据规格书提供。本公司保留技术更改权利。  
Special voltage may be provided according to the requirement. All technical modification rights reserved.

Http://www.xtgygs.cn



### DIMENSIONS DRAWING

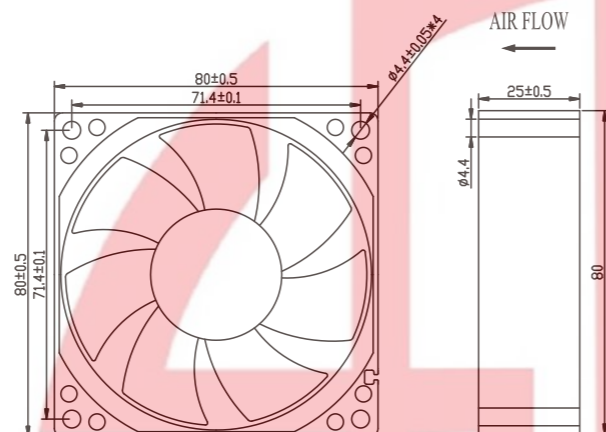

### P & Q CURVE (AT RATED VOLTAGE)

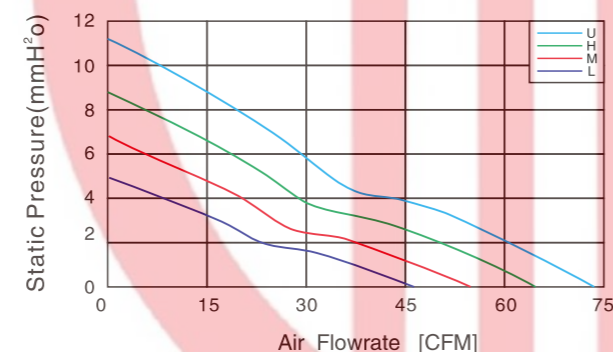

### DC FAN 80\*80\*25MM SERIES

Material  
UL 1007 AWG # 24 OR Equivalent  
Red Wire:Positive (+)  
Black Wire:Negative (-)  
Yellow wire:FG or RD Signal

MODEL NO	RATED VOLTAGE V	OPERATING VOLTAGE V	RATED CURRENT A	ACTUAL CURRENT A	RATED POWER	RATED SPEED RPM (±10%)	MAX. AIR FLOW		MAX.STATIC AIR PRESSURE		NOISE LEVEL db(A)
							CMM	CFM	InH2O	mmH2O	
JL8025U12B	12	6~13.2	0.5	0.45	6	4800	2.084	73.58	0.435	11.04	49.1
JL8025H12Y	12	6~13.2	0.33	0.3	3.96	4200	1.823	64.38	0.333	8.45	46.2
JL8025M12Y	12	6~13.2	0.22	0.19	2.64	3600	1.563	55.2	0.244	6.21	42.8
JL8025L12Y	12	6~13.2	0.12	0.11	1.44	3000	1.303	46	0.170	4.31	38.9
JL8025U24B	24	12~26.4	0.28	0.25	6.72	4800	2.084	73.58	0.435	11.04	49.1
JL8025H24Y	24	12~26.4	0.18	0.16	4.32	4200	1.823	64.38	0.333	8.45	46.2
JL8025M24Y	24	12~26.4	0.11	0.1	2.64	3600	1.563	55.2	0.244	6.21	42.8
JL8025L24Y	24	12~26.4	0.07	0.06	1.68	3000	1.303	46	0.170	4.31	38.9
JL8025U48B	48	24~52.8	0.15	0.13	7.2	4800	2.084	73.58	0.435	11.04	49.1
JL8025H48Y	48	24~52.8	0.1	0.09	4.8	4200	1.823	64.38	0.333	8.45	46.2
JL8025M48Y	48	24~52.8	0.06	0.05	2.88	3600	1.563	55.2	0.244	6.21	42.8
JL8025L48Y	48	24~52.8	0.04	0.03	1.92	3000	1.303	46	0.170	4.31	38.9

PS:Where Y can be S .B.



### DIMENSIONS DRAWING

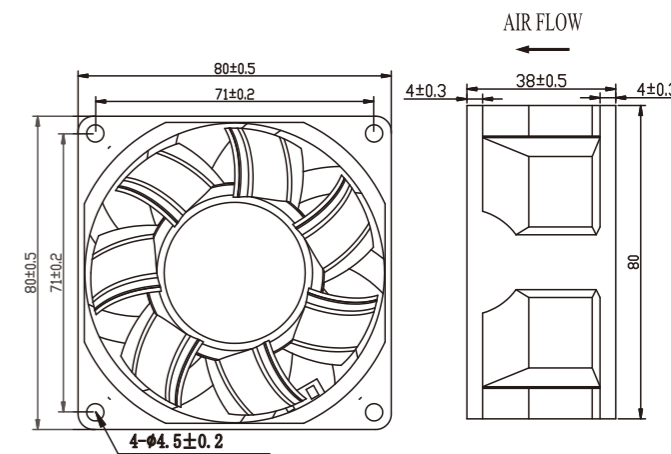

### P & Q CURVE (AT RATED VOLTAGE)

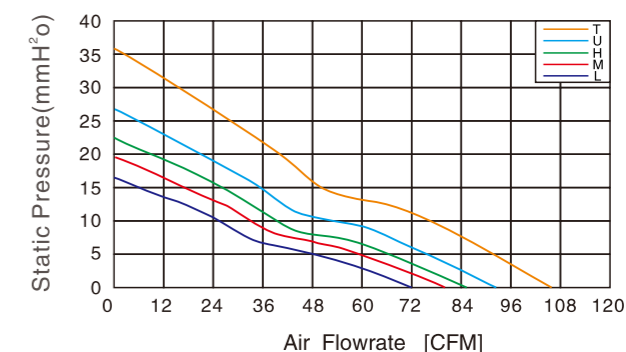

### DC AXIAL FAN 80\*80\*38MM SERIES

Material  
UL 1007 AWG # 24 OR Equivalent  
Red Wire:Positive (+)  
Black Wire:Negative (-)  
Yellow wire:FG or RD Signal

MODEL NO	RATED VOLTAGE V	OPERATING VOLTAGE V	RATED CURRENT A	ACTUAL CURRENT A	RATED POWER	RATED SPEED RPM (±10%)	MAX. AIR FLOW		MAX.STATIC AIR PRESSURE		NOISE LEVEL db(A)
							CMM	CFM	InH2O	mmH2O	
JL8038M12Y	12	6~13.2	0.9	0.8	10.8	6000	2.39	84.4	0.90	22.8	54.8
JL8038L12Y	12	6~13.2	0.8	0.7	9.6	5500	2.19	77.4	0.76	19.2	52.6
JL8038S12Y	12	6~13.2	0.7	0.65	8.4	5000	1.99	70.34	0.62	15.8	49
JL8038U24Y	24	12~26.4	0.8	0.65	19.2	7500	2.99	105.5	1.41	35.7	61.5
JL8038H24Y	24	12~26.4	0.6	0.57	14.4	6500	2.59	91.4	1.06	26.8	58.4
JL8038M24Y	24	12~26.4	0.45	0.42	10.8	6000	2.39	84.4	0.90	22.8	54.8
JL8038L24Y	24	12~26.4	0.38	0.35	9.12	5500	2.19	77.4	0.76	19.2	52.6
JL8038S24Y	24	12~26.4	0.35	0.32	8.4	5000	1.99	70.34	0.62	15.8	49
JL8038U48Y	48	24~52.8	0.48	0.45	23.04	7500	2.99	105.5	1.41	35.7	61.5
JL8038H48Y	48	24~52.8	0.35	0.3	16.8	6500	2.59	91.4	1.06	26.8	58.4
JL8038M48Y	48	24~52.8	0.25	0.2	12	6000	2.39	84.4	0.90	22.8	54.8
JL8038L48Y	48	24~52.8	0.2	0.18	9.6	5500	2.19	77.4	0.76	19.2	52.6
JL8038S48Y	48	24~52.8	0.18	0.16	8.64	5000	1.99	70.34	0.62	15.8	49

PS:Where Y can be S .B.

AC Axial Fan  
AC轴流风机

AC All-Metal Axial Fan  
AC全金属轴流风扇

DC Axial Fan  
DC轴流风机

DC Centrifugal Fan  
DC离心风机

EC Axial Fan  
EC轴流风机

EC Centrifugal Fan  
EC离心风机

AC Centrifugal Fan  
AC离心风机

Fan Accessories  
风机配件



JILONG MOTOR  
AC/DC FANS COOLING FANS



UL  
E248719



本样册仅供参考，具体规格以实物为准。  
This sample book is for reference only. Please refer to the specification for details.  
如需特殊电压也可根据需求提供。本公司保留技术更改权利。  
Special voltage may be provided according to the requirement. All technical modification rights reserved.

Http://www.xtgygs.cn



DIMENSIONS DRAWING

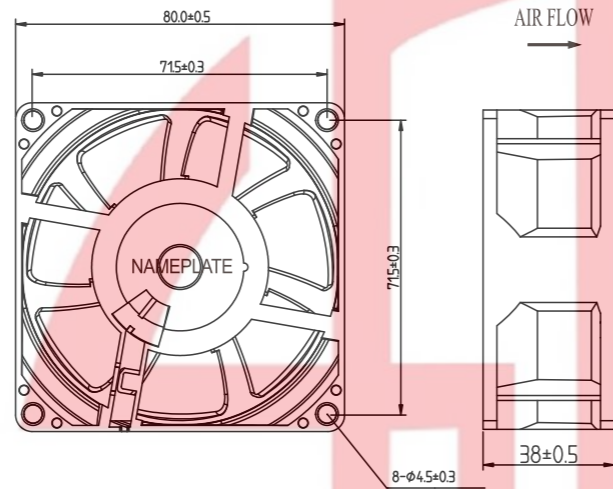

P & Q CURVE (AT RATED VOLTAGE)

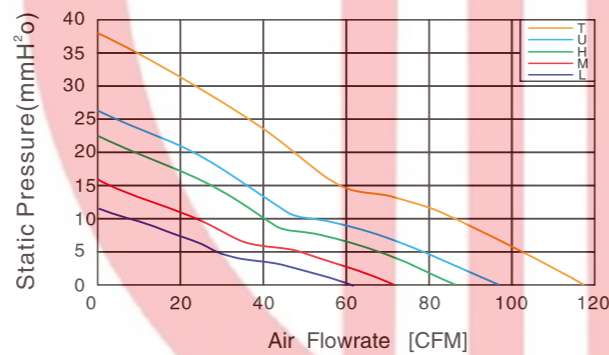

DC FAN  
80\*80\*38MM SERIES

Material  
UL 1007 AWG # 24 OR Equivalent  
Red Wire:Positive (+)  
Black Wire:Negative (-)  
Yellow wire:FG or RD Signal

MODEL NO	RATED VOLTAGE V	OPERATING VOLTAGE V	RATED CURRENT A	ACTUAL CURRENT A	RATED POWER	RATED SPEED RPM (±10%)	MAX. AIR FLOW		MAX.STATIC AIR PRESSURE		NOISE LEVEL db(A)
							CMM	CFM	InH2O	mmH2O	
JL8038H12B	12	6~13.2	1.3	1.2	15.16	6500	2.71	95.68	1.000	25.39	52.6
JL8038M12B	12	6~13.2	1.1	1.0	13.2	6000	2.50	88.32	0.852	21.63	50.8
JL8038L12B	12	6~13.2	0.7	0.65	8.4	5000	2.08	73.6	0.591	15.02	46.0
JL8038T24B	24	12~26.4	1.1	1.0	26.4	8000	3.33	117.76	1.516	38.5	56.5
JL8038U24B	24	12~26.4	0.7	0.65	16.8	6500	2.71	95.68	1.000	25.39	52.6
JL8038H24B	24	12~26.4	0.6	0.55	14.4	6000	2.50	88.32	0.852	21.63	50.8
JL8038M24B	24	12~26.4	0.4	0.35	9.6	5000	2.08	73.6	0.591	15.02	46.0
JL8038L24B	24	12~26.4	0.25	0.22	6	4200	1.75	61.8	0.417	10.6	42.2
JL8038T48B	48	36~52.4	0.7	0.65	33.6	8000	3.33	117.76	1.516	38.5	56.5
JL8038U48B	48	36~52.4	0.35	0.33	16.8	6500	2.71	95.68	1.000	25.39	52.6
JL8038H48B	48	36~52.4	0.3	0.28	14.4	6000	2.50	88.32	0.852	21.63	50.8
JL8038M48B	48	36~52.4	0.2	0.18	9.6	5000	2.08	73.6	0.591	15.02	46.0
JL8038L48B	48	36~52.4	0.13	0.12	6.24	4200	1.75	61.8	0.417	10.6	42.2



DIMENSIONS DRAWING

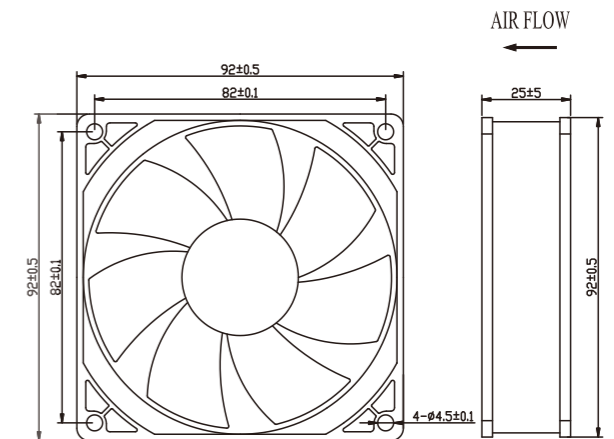

P & Q CURVE (AT RATED VOLTAGE)

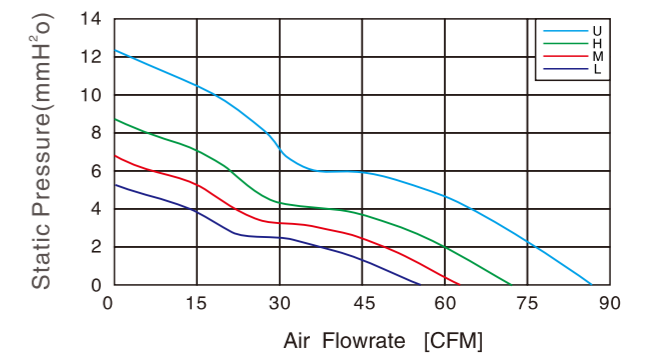

DC AXIAL FAN  
92\*92\*25MM SERIES

Material  
UL 1007 AWG # 24 OR Equivalent  
Red Wire:Positive (+)  
Black Wire:Negative (-)  
Yellow wire:FG or RD Signal

MODEL NO	RATED VOLTAGE V	OPERATING VOLTAGE V	RATED CURRENT A	ACTUAL CURRENT A	RATED POWER	RATED SPEED RPM (±10%)	MAX. AIR FLOW		MAX.STATIC AIR PRESSURE		NOISE LEVEL db(A)
							CMM	CFM	InH2O	mmH2O	
JL9225U12Y	12	6~13.2	0.85	0.78	10.2	4800	2.40	84.8	0.484	12.3	43.8
JL9225H12Y	12	6~13.2	0.5	0.48	6.0	4000	2.00	70.7	0.337	8.56	39.9
JL9225M12Y	12	6~13.2	0.2	0.18	2.4	3500	1.75	61.8	0.258	6.55	37.0
JL9225L12Y	12	6~13.2	0.14	0.12	1.68	3000	1.50	53.03	0.190	4.82	33.7
JL9225U24Y	24	12~26.4	0.4	0.36	9.6	4800	2.40	84.8	0.484	12.3	43.8
JL9225H24Y	24	12~26.4	0.3	0.26	7.2	4000	2.00	70.7	0.337	8.56	39.9
JL9225M24Y	24	12~26.4	0.23	0.2	5.52	3500	1.75	61.8	0.258	6.55	37.0
JL9225L24Y	24	12~26.4	1.05	0.13	25.2	3000	1.50	53.03	0.190	4.82	33.7
JL9225U48Y	48	24~52.8	0.35	0.3	16.8	4800	2.40	84.8	0.484	12.3	43.8
JL9225H48Y	48	24~52.8	0.23	0.2	11.04	4000	2.00	70.7	0.337	8.56	39.9
JL9225M48Y	48	24~52.8	0.12	0.1	5.76	3500	1.75	61.8	0.258	6.55	37.0
JL9225L48Y	48	24~52.8	0.08	0.07	3.84	3000	1.50	53.03	0.190	4.82	33.7

■ PS:Where Y can be S .B.



JULONG MOTOR  
AC/DC FANS COOLING FANS



本样册仅供参考，具体以规格书为准。  
This sample book is for reference only. Please refer to the specification for details.  
如需特殊电压也可根据规格书提供。本公司保留技术更改权利。  
Special voltage may be provided according to the requirement. All technical modification rights reserved.

Http://www.xtgygs.cn



DIMENSIONS DRAWING

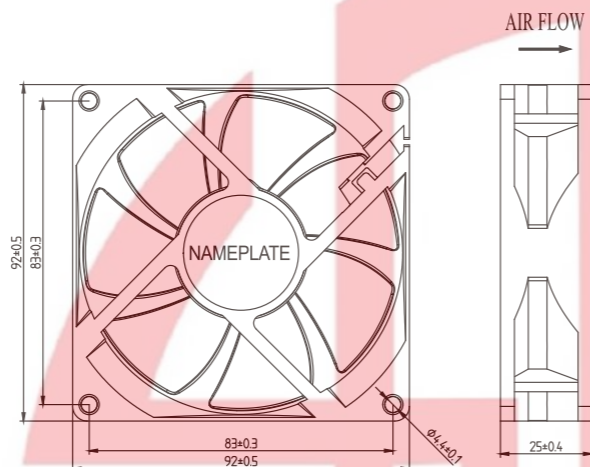

DC FAN  
92\*92\*25MM SERIES

Material  
UL 1007 AWG # 24 OR Equivalent  
Red Wire:Positive (+)  
Black Wire:Negative (-)  
Yellow wire:FG or RD Signal

P & Q CURVE (AT RATED VOLTAGE)

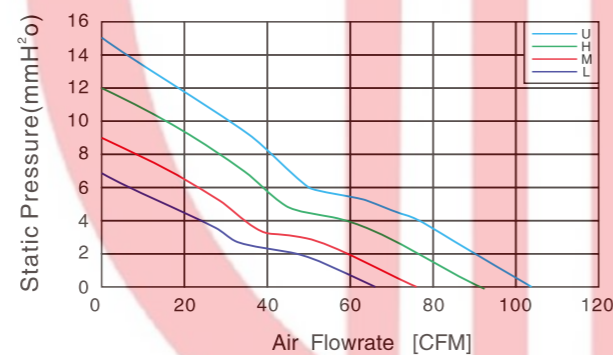

MODEL NO	RATED VOLTAGE V	OPERATING VOLTAGE V	RATED CURRENT A	ACTUAL CURRENT A	RATED POWER	RATED SPEED RPM (±10%)	MAX. AIR FLOW		MAX.STATIC AIR PRESSURE		NOISE LEVEL db(A)
							CMM	CFM	InH <sub>2</sub> O	mmH <sub>2</sub> O	
JL9225U12Y	12	6~13.2	0.9	0.82	10.8	5500	3.222	100.9	0.579	14.7	52.4
JL9225H12Y	12	6~13.2	0.7	0.65	8.4	5000	2.931	91.77	0.479	12.16	48.5
JL9225M12Y	12	6~13.2	0.4	0.35	4.8	4200	2.461	77.08	0.326	8.28	44.7
JL9225L12Y	12	6~13.2	0.28	0.25	3.36	3600	2.110	66.07	0.248	6.3	41.4
JL9225U24Y	24	12~26.4	0.6	0.58	14.4	6000	3.517	110.12	0.689	17.51	52.4
JL9225H24Y	24	12~26.4	0.35	0.34	8.4	5000	2.931	91.77	0.479	12.16	48.5
JL9225M24Y	24	12~26.4	0.2	0.18	4.8	4200	2.461	77.08	0.326	8.28	44.7
JL9225L24Y	24	12~26.4	0.14	0.13	3.36	3600	2.11	66.07	0.248	6.3	41.4

PS:Where Y can be S .B.



DIMENSIONS DRAWING

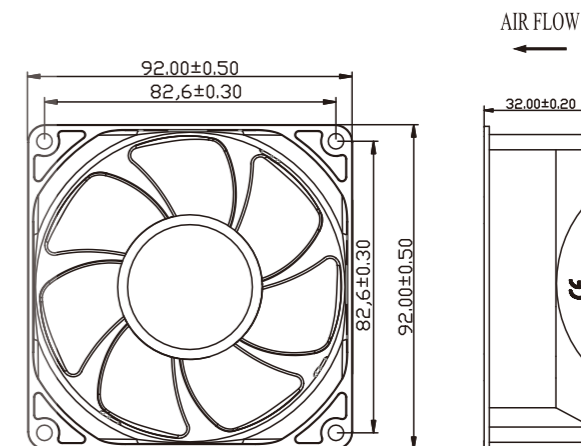

DC AXIAL FAN  
92\*92\*32MM SERIES

Material  
UL 1007 AWG # 24 OR Equivalent  
Red Wire:Positive (+)  
Black Wire:Negative (-)  
Yellow wire:FG or RD Signal

P & Q CURVE (AT RATED VOLTAGE)

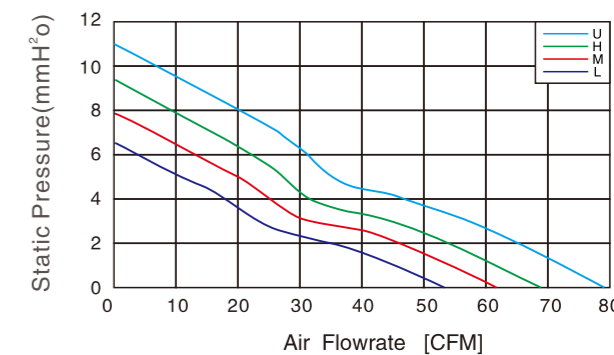

MODEL NO	RATED VOLTAGE V	OPERATING VOLTAGE V	RATED CURRENT A	ACTUAL CURRENT A	RATED POWER	RATED SPEED RPM (±10%)	MAX. AIR FLOW		MAX.STATIC AIR PRESSURE		NOISE LEVEL db(A)
							CMM	CFM	InH <sub>2</sub> O	mmH <sub>2</sub> O	
JL9232H12B	12	6~13.2	0.68	0.62	8.2	4000	1.93	68.2	0.378	9.60	43.6
JL9232M12Y	12	6~13.2	0.49	0.43	5.9	3500	1.72	60.8	0.311	7.90	40.5
JL9232L12Y	12	6~13.2	0.35	0.32	4.2	3000	1.51	53.4	0.240	6.10	37.5
JL9232U24B	24	12~26.4	0.48	0.45	11.5	4500	2.21	78.1	0.425	10.80	46.3
JL9232H24B	24	12~26.4	0.37	0.35	8.9	4000	1.93	68.2	0.378	9.60	43.6
JL9232M24Y	24	12~26.4	0.25	0.22	6.0	3500	1.72	60.8	0.311	7.90	40.5
JL9232L24Y	24	12~26.4	0.18	0.16	4.3	3000	1.51	53.4	0.240	6.10	37.5
JL9232U48B	48	24~52.8	0.23	0.21	11.0	4500	2.21	78.1	0.425	10.80	46.3
JL9232H48B	48	24~52.8	0.18	0.16	8.6	4000	1.93	68.2	0.378	9.60	43.6
JL9232M48Y	48	24~52.8	0.13	0.12	6.2	3500	1.72	60.8	0.311	7.90	40.5
JL9232L48Y	48	24~52.8	0.11	0.1	5.3	3000	1.51	53.4	0.240	6.10	37.5

PS:Where Y can be S .B.



JULONG MOTOR  
AC/DC FANS COOLING FANS



UL  
E248719



本样机仅供参考，具体以规格书为准。  
This sample book is for reference only. Please refer to the specification for details.  
如需特殊电压也可根据规格书提供。本公司保留技术知识产权。  
Special voltage may be provided according to the requirement. All technical modification rights reserved.

Http://www.xtgygs.cn



### DIMENSIONS DRAWING

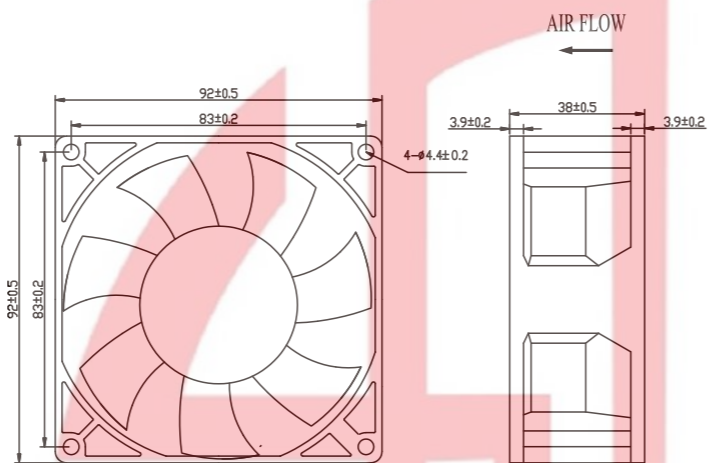

### DC AXIAL FAN 92\*92\*38MM SERIES

Material  
UL 1007 AWG # 24 OR Equivalent  
Red Wire:Positive (+)  
Black Wire:Negative (-)  
Yellow wire:FG or RD Signal

### P & Q CURVE (AT RATED VOLTAGE)

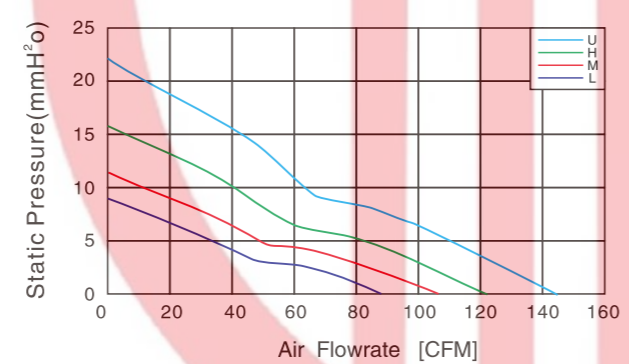

MODEL NO	RATED VOLTAGE V	OPERATING VOLTAGE V	RATED CURRENT A	ACTUAL CURRENT A	RATED POWER	RATED SPEED RPM (±10%)	MAX. AIR FLOW		MAX.STATIC AIR PRESSURE		NOISE LEVEL db(A)
							CMM	CFM	InH <sub>2</sub> O	mmH <sub>2</sub> O	
JL9238H12B	12	6~13.2	1.0	0.9	12.0	4800	3.38	119.20	0.606	15.40	53.9
JL9238M12Y	12	6~13.2	0.7	0.65	8.4	4200	2.95	104.30	0.465	11.80	51.1
JL9238L12Y	12	6~13.2	0.5	0.45	6.0	3600	2.53	89.37	0.341	8.66	47.7
JL9238U24B	24	12~26.4	0.9	0.88	21.6	5800	4.08	144.00	0.885	22.49	58.1
JL9238H24B	24	12~26.4	0.65	0.6	15.6	4800	3.38	119.20	0.606	15.40	53.9
JL9238M24Y	24	12~26.4	0.4	0.38	9.6	4200	2.95	104.30	0.465	11.80	51.1
JL9238L24Y	24	12~26.4	0.3	0.28	7.2	3600	2.53	89.37	0.341	8.66	47.7
JL9238U48B	48	24~52.8	0.55	0.5	26.4	5800	4.08	144.00	0.885	22.49	58.1
JL9238H48B	48	24~52.8	0.38	0.35	18.2	4800	3.38	119.2	0.606	15.40	53.9
JL9238M48Y	48	24~52.8	0.25	0.22	12.0	4200	2.95	104.3	0.465	11.80	51.1
JL9238L48Y	48	24~52.8	0.18	0.28	8.6	3600	2.53	89.37	0.341	8.66	47.7

PS:Where Y can be S .B.

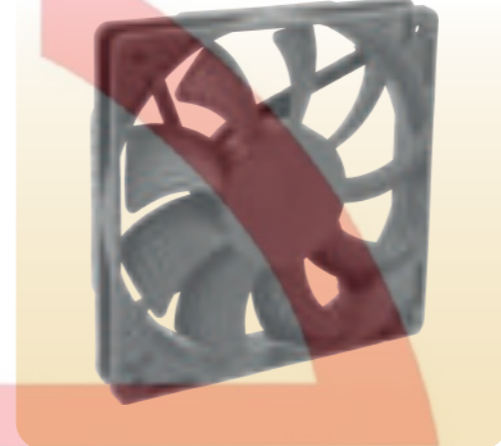

### DIMENSIONS DRAWING

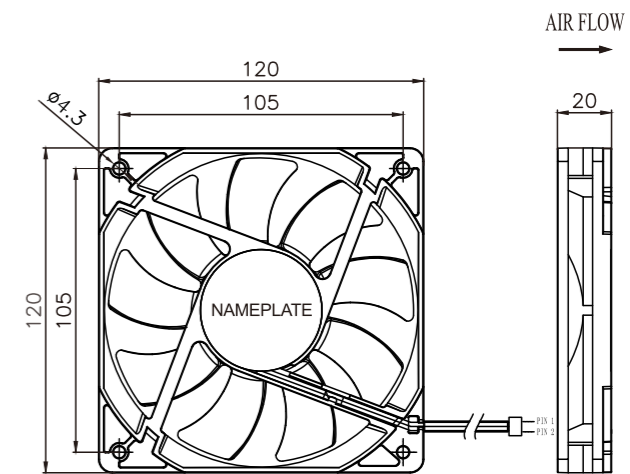

### DC FAN 120\*120\*20MM SERIES

Material  
UL 1007 AWG # 24 OR Equivalent  
Red Wire:Positive (+)  
Black Wire:Negative (-)  
Yellow wire:FG or RD Signal

### P & Q CURVE (AT RATED VOLTAGE)

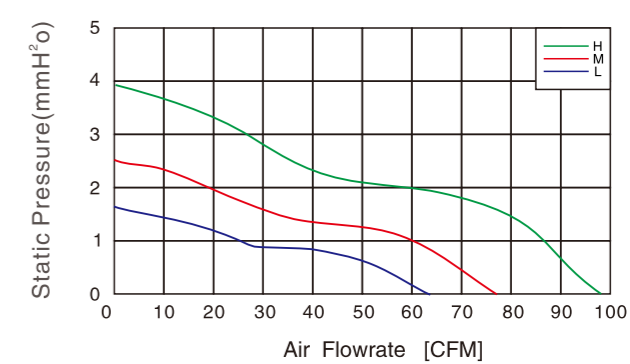

MODEL NO	RATED VOLTAGE V	OPERATING VOLTAGE V	RATED CURRENT A	ACTUAL CURRENT A	RATED POWER	RATED SPEED RPM (±10%)	MAX. AIR FLOW		MAX.STATIC AIR PRESSURE		NOISE LEVEL db(A)
							CMM	CFM	InH <sub>2</sub> O	mmH <sub>2</sub> O	
JL12020H12Y	12	7~13.2	0.38	0.37	4.56	2800	2.70	95.20	0.150	3.8	39.2
JL12020M12Y	12	7~13.2	0.2	0.18	2.4	2200	2.12	74.80	0.093	2.35	33.9
JL12020L12Y	12	7~13.2	0.12	0.10	1.44	1800	1.73	61.20	0.062	1.57	29.6
JL12020H18Y	18	12~19.8	0.28	0.26	5.04	2800	2.70	95.20	0.150	3.8	39.2
JL12020M18Y	18	12~19.8	0.15	0.13	2.7	2200	2.12	74.80	0.093	2.35	33.9
JL12020L18Y	18	12~19.8	0.09	0.08	1.62	1800	1.73	61.20	0.062	1.57	29.6

PS:Where Y can be S .B.

AC Axial Fan  
AC轴流风机

AC All-Metal Axial Fan  
AC全金属轴流风扇

DC Axial Fan  
DC轴流风机

DC Centrifugal Fan  
DC离心风机

EC Axial Fan  
EC轴流风机

EC Centrifugal Fan  
EC离心风机

AC Centrifugal Fan  
AC离心风机

Fan Accessories  
风机配件



JULONG MOTOR  
AC/DC FANS COOLING FANS



本样册仅供参考，具体以规格书为准。  
This sample book is for reference only. Please refer to the specification for details.  
如需特殊电压也可根据规格提供。本公司保留技术更改权利。  
Special voltage may be provided according to the requirement. All technical modification rights reserved.

Http://www.xtgygs.cn



### DIMENSIONS DRAWING

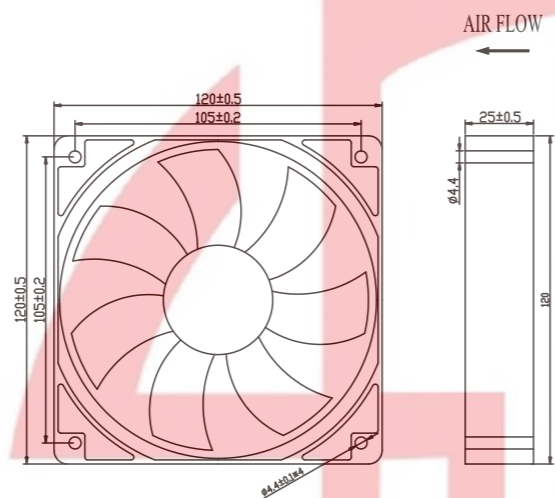

### P & Q CURVE (AT RATED VOLTAGE)

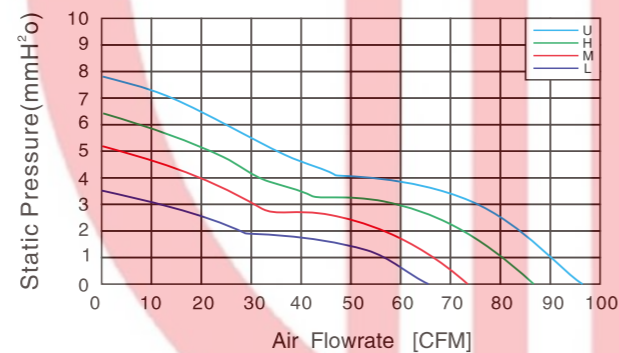

## DC AXIAL FAN 120\*120\*25MM 2 SERIES

Material  
UL 1007 AWG # 24 OR Equivalent  
Red Wire:Positive (+)  
Black Wire:Negative (-)  
Yellow wire:FG or RD Signal

MODEL NO	RATED VOLTAGE V	OPERATING VOLTAGE V	RATED CURRENT A	ACTUAL CURRENT A	RATED POWER	RATED SPEED RPM (±10%)	MAX. AIR FLOW		MAX.STATIC AIR PRESSURE		NOISE LEVEL db(A)
							CMM	CFM	InH <sub>2</sub> O	mmH <sub>2</sub> O	
JL12025U12Y	12	7~13.2	0.6	0.68	9.6	2800	2.71	95.70	0.304	7.73	41.3
JL12025H12Y	12	7~13.2	0.6	0.45	7.2	2500	2.34	82.64	0.246	6.25	38.6
JL12025M12Y	12	7~13.2	0.45	0.39	5.4	2200	2.10	74.16	0.203	5.15	35.5
JL12025L12Y	12	7~13.2	0.25	0.22	3.0	1800	1.90	67.00	0.139	3.52	31.3
JL12025U24Y	24	14~26.4	0.4	0.36	9.60	2800	2.71	95.70	0.304	7.73	41.3
JL12025H24Y	24	14~26.4	0.28	0.24	6.72	2500	2.34	82.64	0.246	6.25	38.6
JL12025M24Y	24	14~26.4	0.22	0.2	5.28	2200	2.10	74.16	0.203	5.15	35.5
JL12025L24Y	24	14~26.4	0.14	0.12	3.36	1800	1.90	67.00	0.139	3.52	31.3

■ PS:Where Y can be S .B.

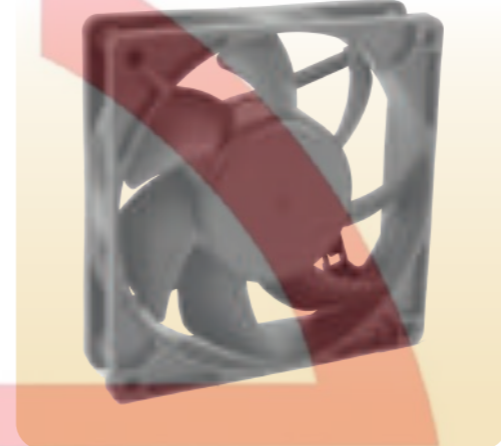

### DIMENSIONS DRAWING

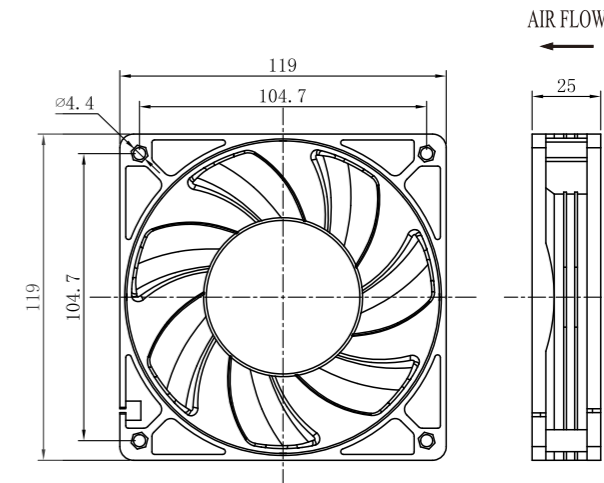

### P & Q CURVE (AT RATED VOLTAGE)

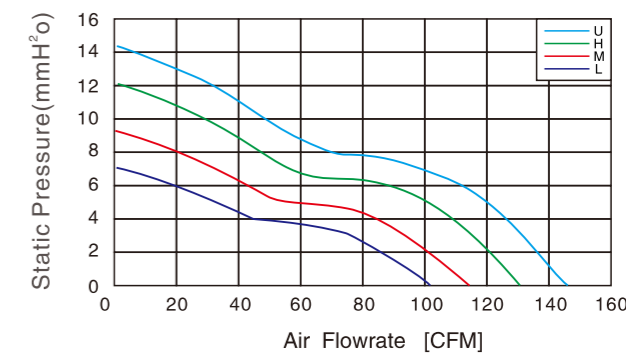

## DC FAN 120 \* 120 \* 25MM SERIES

Material  
UL 1007 AWG # 24 OR Equivalent  
Red Wire:Positive (+)  
Black Wire:Negative (-)  
Yellow wire:FG or RD Signal

MODEL NO	RATED VOLTAGE V	OPERATING VOLTAGE V	RATED CURRENT A	ACTUAL CURRENT A	RATED POWER	RATED SPEED RPM (±10%)	MAX. AIR FLOW		MAX.STATIC AIR PRESSURE		NOISE LEVEL db(A)
							CMM	CFM	InH <sub>2</sub> O	mmH <sub>2</sub> O	
JL12025H12Y	12	7~13.2	1.0	0.95	12	4000	3.62	128.0	0.465	11.8	50.2
JL12025M12Y	12	7~13.2	0.8	0.7	9.6	3500	3.12	110.3	0.355	9.01	47.0
JL12025L12Y	12	7~13.2	0.5	0.45	6.0	3100	2.80	99.00	0.299	7.6	43.7
JL12025U24Y	24	14~26.4	0.7	0.63	16.8	4500	4.04	142.7	0.559	14.2	53.0
JL12025H24Y	24	14~26.4	0.5	0.45	12.00	4000	3.62	128.0	0.465	11.8	50.2
JL12025M24Y	24	14~26.4	0.3	0.27	7.20	3500	3.12	110.3	0.355	9.01	47.0
JL12025L24Y	24	14~26.4	0.2	0.18	4.80	3100	2.80	99.00	0.299	7.6	43.7
JL12025U24Y	24	14~26.4	0.4	0.36	9.60	4500	4.04	142.7	0.559	14.2	53.0
JL12025H24Y	24	14~26.4	0.28	0.26	6.72	4000	3.62	128.0	0.465	11.8	50.2
JL12025M24Y	24	14~26.4	0.22	0.2	5.28	3500	3.12	110.3	0.355	9.01	47.0
JL12025L24Y	24	14~26.4	0.15	0.13	3.36	3100	2.80	99.00	0.299	7.6	43.7

■ PS:Where Y can be S .B.



JULONG MOTOR  
AC/DC FANS COOLING FANS



UL  
E248719



本样品的制造型号仅供参考，具体以规格书为准。  
This sample book is for reference only. Please refer to the specification for details.  
如需特殊电压也可根据规格提供。本公司保留技术更改权利。  
Special voltage may be provided flexibly according to the enquiry. All rights reserved.

Http://www.xtgygs.cn



DIMENSIONS DRAWING

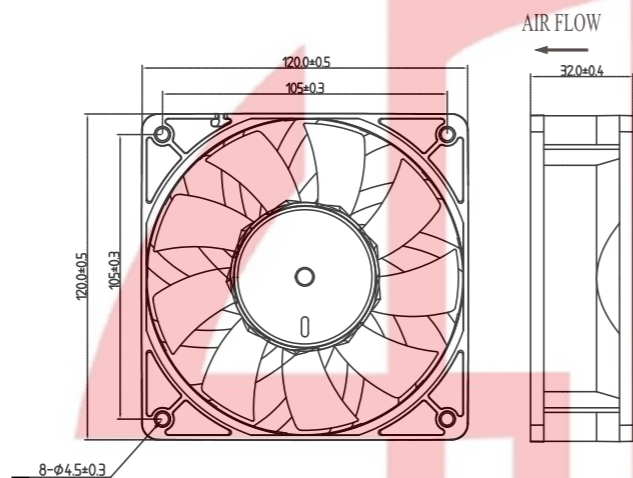

P & Q CURVE (AT RATED VOLTAGE)

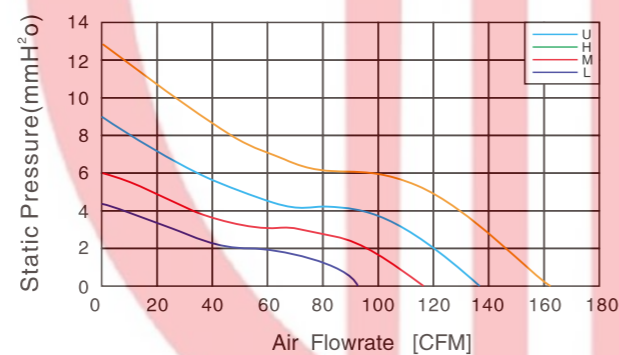

DC FAN  
120\*120\*32MM SERIES

Material  
UL 1007 AWG # 24 OR Equivalent  
Red Wire:Positive (+)  
Black Wire:Negative (-)  
Yellow wire:FG or RD Signal

MODEL NO	RATED VOLTAGE V	OPERATING VOLTAGE V	RATED CURRENT A	ACTUAL CURRENT A	RATED POWER	RATED SPEED RPM (±10%)	MAX. AIR FLOW		MAX.STATIC AIR PRESSURE		NOISE LEVEL db(A)
							CMM	CFM	InH2O	mmH2O	
JL12032H12Y	12	6~13.2	2.60	2.4	31.2	3800	5.24	184.9	0.591	15.01	50.3
JL12032M12Y	12	6~13.2	1.30	1.2	15.60	3200	4.41	155.7	0.419	10.64	46.6
JL12032L12Y	12	6~13.2	0.90	0.8	10.80	2700	3.72	131.4	0.298	7.58	42.9
JL12032H24Y	24	12~26.4	1.30	1.2	31.20	3800	5.24	184.9	0.591	15.01	50.3
JL12032M24Y	24	12~26.4	0.65	0.6	15.60	3200	4.41	155.7	0.419	10.64	46.6
JL12032L24Y	24	12~26.4	0.45	0.4	10.80	2700	3.72	131.4	0.298	7.58	42.9
JL12032H48Y	48	24~52.8	0.65	0.58	31.20	3800	5.24	184.9	0.591	15.01	50.3
JL12032M48Y	48	24~52.8	0.35	0.29	16.80	3200	4.41	155.7	0.419	10.64	46.6
JL12032L48Y	48	24~52.8	0.22	0.2	10.56	2700	3.72	131.4	0.298	7.58	42.9

PS:Where Y can be S .B.



DIMENSIONS DRAWING

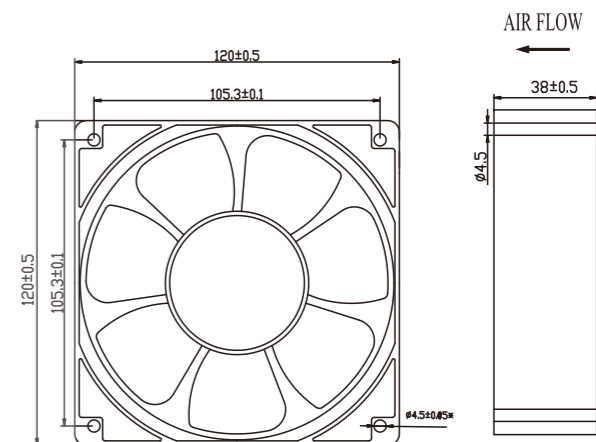

DC AXIAL FAN  
120\*120\*38MM 1 SERIES

Material  
UL 1007 AWG # 24 OR Equivalent  
Red Wire:Positive (+)  
Black Wire:Negative (-)  
Yellow wire:FG or RD Signal

P & Q CURVE (AT RATED VOLTAGE)

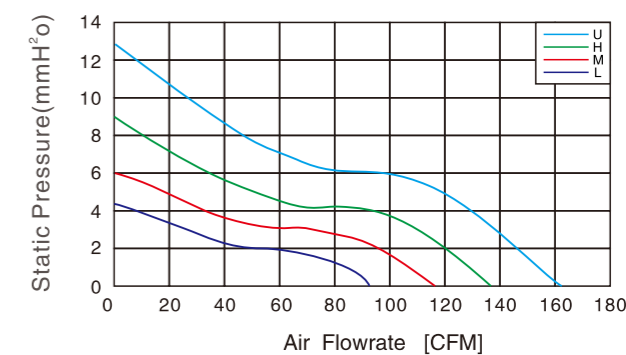

MODEL NO	RATED VOLTAGE V	OPERATING VOLTAGE V	RATED CURRENT A	ACTUAL CURRENT A	RATED POWER	RATED SPEED RPM (±10%)	MAX. AIR FLOW		MAX.STATIC AIR PRESSURE		NOISE LEVEL db(A)
							CMM	CFM	InH2O	mmH2O	
JL12038H12Y	12	6~13.2	1.1	1.0	13.2	4000	4.51	159.2	0.484	12.3	50.1
JL12038M12Y	12	6~13.2	0.8	0.72	9.6	3400	3.83	135.3	0.350	8.9	46.6
JL12038L12Y	12	6~13.2	0.4	0.36	4.8	2800	3.15	111.4	0.238	6.04	42.4
JL12038U24B	24	12~26.4	1.6	1.4	19.2	5400	6.09	214.9	0.882	22.4	56.6
JL12038H24Y	24	12~26.4	0.65	0.59	15.6	4000	4.51	159.2	0.484	12.3	50.1
JL12038M24Y	24	12~26.4	0.35	0.32	8.4	3400	3.83	135.3	0.350	8.9	46.6
JL12038L24Y	24	12~26.4	0.2	0.18	4.8	2800	3.15	111.4	0.238	6.04	42.4
JL12038U48B	48	24~52.8	0.8	0.75	19.2	5400	6.09	214.9	0.882	22.4	56.6
JL12038H48Y	48	24~52.8	0.3	0.27	14.4	4000	4.51	159.2	0.484	12.3	50.1
JL12038M48Y	48	24~52.8	0.25	0.2	12.0	3400	3.83	135.3	0.350	8.9	46.6
JL12038L48Y	48	24~52.8	0.15	0.12	7.2	2800	3.15	111.4	0.238	6.04	42.4

PS:Where Y can be S .B.



JULONG MOTOR  
AC/DC FANS COOLING FANS



本样册仅供参考，具体规格以实物为准。  
This sample book is for reference only. Please refer to the specification for details.  
如需特殊电压也可根据需求提供。本公司保留技术更改权利。  
Special voltage may be provided flexibly according to the requirement. All technical modification rights reserved.

Http://www.xtgygs.cn



DIMENSIONS DRAWING

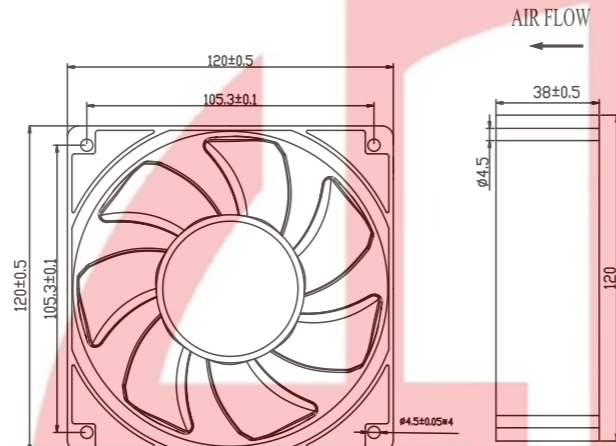

P & Q CURVE (AT RATED VOLTAGE)

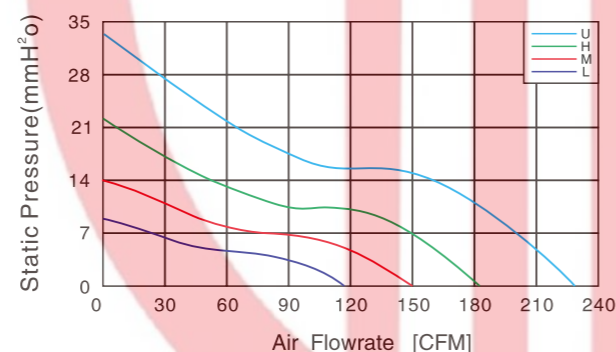

DC FAN  
120\*120\*38MM SERIES

Material  
UL 1007 AWG # 24 OR Equivalent  
Red Wire:Positive (+)  
Black Wire:Negative (-)  
Yellow wire:FG or RD Signal

MODEL NO	RATED VOLTAGE V	OPERATING VOLTAGE V	RATED CURRENT A	ACTUAL CURRENT A	RATED POWER	RATED SPEED RPM (±10%)	MAX. AIR FLOW		MAX.STATIC AIR PRESSURE		NOISE LEVEL db(A)
							CMM	CFM	InH2O	mmH2O	
JL12038M12Y	12	6~13.2	1.00	0.4	12.00	3600	4.21	148.64	0.539	13.68	49
JL12038L12Y	12	6~13.2	0.65	0.31	7.80	3100	3.63	128.1	0.399	10.14	46
JL12038U24B	24	12~26.4	2.2	2.0	52.80	5500	6.43	227.1	1.257	31.92	58.2
JL12038H24B	24	12~26.4	1.30	1.2	31.20	4500	5.26	185.8	0.841	21.37	53.8
JL12038M24Y	24	12~26.4	0.5	0.46	12.00	3600	4.21	148.64	0.539	13.68	49
JL12038L24Y	24	12~26.4	0.34	0.31	8.16	3100	3.63	128.1	0.399	10.14	46
JL12038U48B	48	24~52.8	1.2	1.1	57.60	5500	6.43	227.1	1.257	31.92	58.2
JL12038H48B	48	24~52.8	0.6	0.24	28.80	4500	5.26	185.8	0.841	21.37	53.8
JL12038M48Y	48	24~52.8	0.28	0.18	13.44	3600	4.21	148.64	0.539	13.68	49
JL12038L48Y	48	24~52.8	0.18	0.08	8.64	3100	3.63	128.1	0.399	10.14	46

PS:Where Y can be S .B.



DIMENSIONS DRAWING

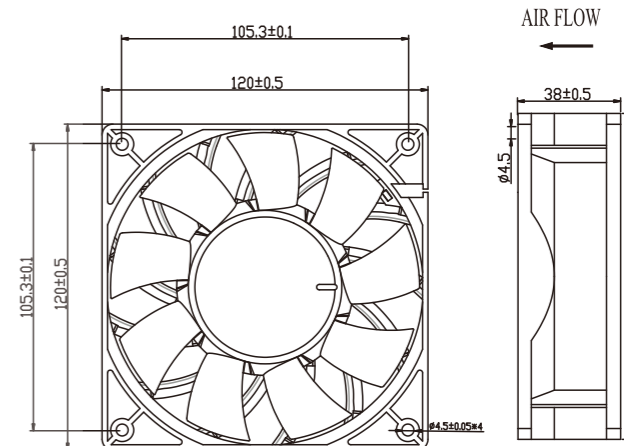

P & Q CURVE (AT RATED VOLTAGE)

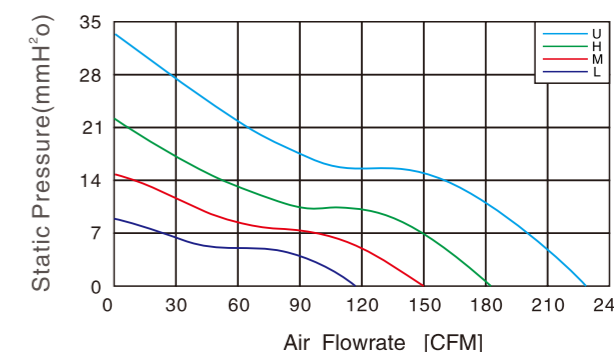

DC FAN  
120\*120\*38MM SERIES

Material  
UL 1007 AWG # 24 OR Equivalent  
Red Wire:Positive (+)  
Black Wire:Negative (-)  
Yellow wire:FG Signal

MODEL NO	RATED VOLTAGE V	OPERATING VOLTAGE V	RATED CURRENT A	ACTUAL CURRENT A	RATED POWER	RATED SPEED RPM (±10%)	MAX. AIR FLOW		MAX.STATIC AIR PRESSURE		NOISE LEVEL db(A)
							CMM	CFM	InH2O	mmH2O	
JL12038M12B	12	6~13.2	3.0	2.9	36	4500	6.51	230.1	0.817	20.76	51.3
JL12038L12B	12	6~13.2	2.2	2.0	26.4	4100	5.94	209.6	0.607	15.43	49.3
JL12038U24B	24	12~26.4	1.8	1.5	21.6	3600	5.21	184.0	0.478	12.15	46.7
JL12038H24B	24	12~26.4	1.8	1.7	43.2	4800	6.95	245.4	0.831	21.10	52.7
JL12038M24B	24	12~26.4	1.3	1.5	31.2	4500	6.51	230.1	0.817	20.76	51.3
JL12038L24B	24	12~26.4	1.0	1.1	24	4100	5.94	209.6	0.607	15.43	49.3
JL12038U48B	48	24~52.8	0.9	0.8	21.6	3600	5.21	184.0	0.478	12.15	46.7
JL12038H48B	48	24~52.8	1.0	0.9	48	4800	6.95	245.4	0.831	21.10	52.7
JL12038M48B	48	24~52.8	0.9	0.8	43.2	4500	6.51	230.1	0.817	20.76	51.3
JL12038L48B	48	24~52.8	0.7	0.6	33.6	4100	5.94	209.6	0.607	15.43	49.3
JL12038M48B	48	24~52.8	0.6	0.5	28.8	3600	5.21	184.0	0.478	12.15	46.7

AC Axial Fan  
AC轴流风机

AC All-Metal Axial Fan  
AC全金属轴流风扇

DC Axial Fan  
DC轴流风机

DC Centrifugal Fan  
DC离心风机

EC Axial Fan  
EC轴流风机

EC Centrifugal Fan  
EC离心风机

AC Centrifugal Fan  
AC离心风机

Fan Accessories  
风机配件



JULONG MOTOR  
AC/DC FANS COOLING FANS



UL 1007  
AWG #20



本样机仅供参考，具体以规格书为准。  
This sample book is for reference only. Please refer to the specification for details.  
如需特殊电压也可特别定制提供。本公司保留技术知识产权。  
Special voltage may be provided flexibly according to the requirement. All technical modification rights reserved.

Http://www.xtgygs.cn



### DIMENSIONS DRAWING

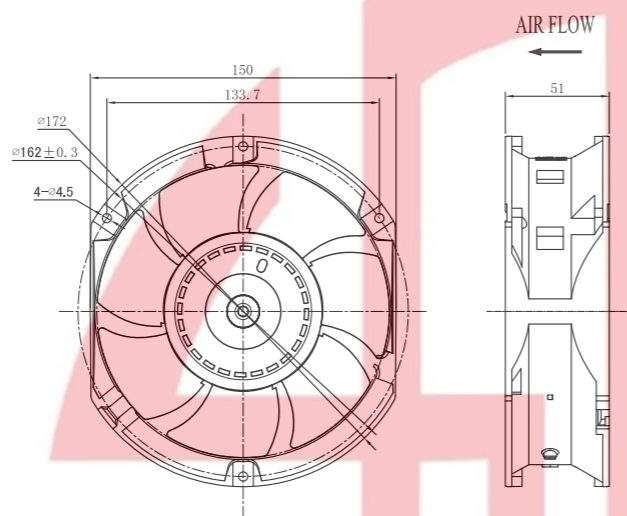

### DC FAN 172\*150\*51MM SERIES

Material  
UL 1007 AWG # 22 OR Equivalent  
Red Wire:Positive (+)  
Black Wire:Negative (-)  
Yellow wire:FG or RD Signal

### P & Q CURVE (AT RATED VOLTAGE)

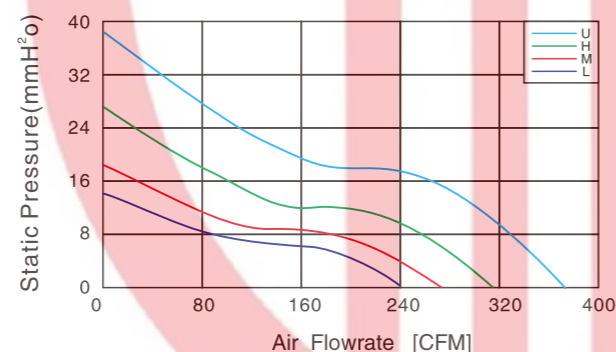

MODEL NO	RATED VOLTAGE V	OPERATING VOLTAGE V	RATED CURRENT A	ACTUAL CURRENT A	RATED POWER	RATED SPEED RPM (±10%)	MAX. AIR FLOW		MAX.STATIC AIR PRESSURE		NOISE LEVEL db(A)
							CMM	CFM	InH <sub>2</sub> O	mmH <sub>2</sub> O	
JL17251L12B	12	8~13.2	1.40	1.35	16.80	3100	6.83	241.35	0.643	16.33	55.4
JL17251S12B	12	8~13.2	0.65	0.31	7.80	2600	5.73	202.42	0.452	11.49	51.5
JL17251U24B	24	18~26.4	2.60	2.5	62.40	4800	10.58	373.68	1.541	39.15	64.9
JL17251H24B	24	18~26.4	1.50	1.45	36.00	4000	8.82	311.40	1.068	27.12	60.9
JL17251M24B	24	18~26.4	1.00	0.95	24.00	3500	7.72	272.49	0.819	20.80	58.0
JL17251L24B	24	18~26.4	0.70	0.63	16.80	3100	6.83	241.35	0.643	16.33	55.4
JL17251U48B	48	36~52.8	1.40	1.1	67.20	4800	10.58	373.68	1.541	39.15	64.9
JL17251H48B	48	36~52.8	0.90	0.82	43.20	4000	8.82	311.40	1.068	27.12	60.9
JL17251M48B	48	36~52.8	0.60	0.55	28.80	3500	7.72	272.49	0.819	20.80	58.0
JL17251L48B	48	36~52.8	0.40	0.35	19.20	3100	6.83	241.35	0.643	16.33	55.4

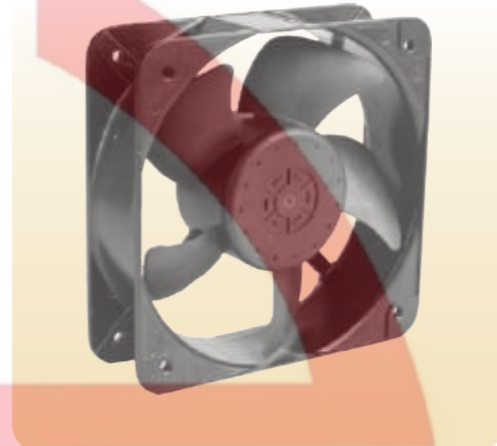

### DIMENSIONS DRAWING

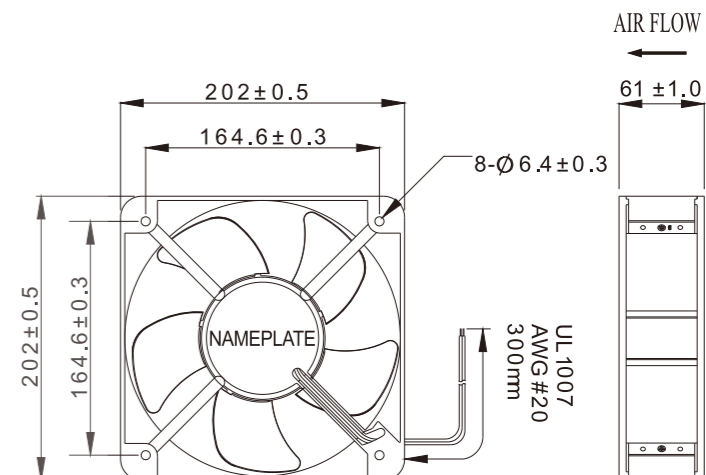

### DC BLOWER 200\*200\*60MM SERIES

Material  
UL 1007 AWG # 24 OR Equivalent  
Red Wire:Positive (+)  
Black Wire:Negative (-)  
Yellow wire:FG Signal or RD Signal

### P & Q CURVE (AT RATED VOLTAGE)

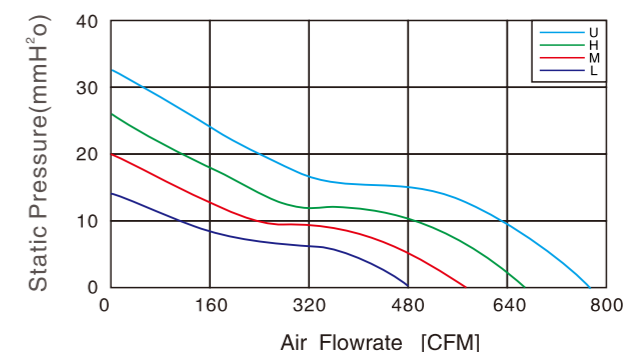

MODEL NO	RATED VOLTAGE V	OPERATING VOLTAGE V	RATED CURRENT A	ACTUAL CURRENT A	RATED POWER	RATED SPEED RPM (±10%)	MAX. AIR FLOW		MAX.STATIC AIR PRESSURE		NOISE LEVEL db(A)
							CMM	CFM	InH <sub>2</sub> O	mmH <sub>2</sub> O	
JL20060H24B	24	18~26.4	2.40	1.6	57.60	2800	18.55	655.0	1.00	25.40	67
JL20060M24B	24	18~26.4	1.80	1.3	43.20	2500	16.56	584.8	0.80	20.20	64.5
JL20060L24B	24	18~26.4	1.40	1.00	33.60	2200	14.57	514.6	0.62	15.70	61.7
JL20060U48B	48	36~52.8	1.50	1.1	72.00	3200	21.20	748.6	1.24	31.60	69.9
JL20060H48B	48	36~52.8	1.20	0.8	57.60	2800	18.55	655.0	1.00	25.40	67.00
JL20060M48B	48	36~52.8	0.90	0.65	43.20	2500	16.56	584.8	0.80	20.20	64.50
JL20060L48B	48	36~52.8	0.70	0.55	33.60	2200	14.57	514.6	0.62	15.70	61.70

AC Axial Fan  
AC轴流风机

AC All-Metal Axial Fan  
AC全金属轴流风扇

DC Axial Fan  
DC轴流风机

DC Centrifugal Fan  
DC离心风机

EC Axial Fan  
EC轴流风机

EC Centrifugal Fan  
EC离心风机

AC Centrifugal Fan  
AC离心风机

Fan Accessories  
风机配件



JULONG MOTOR  
AC/DC FANS COOLING FANS



### DIMENSIONS DRAWING

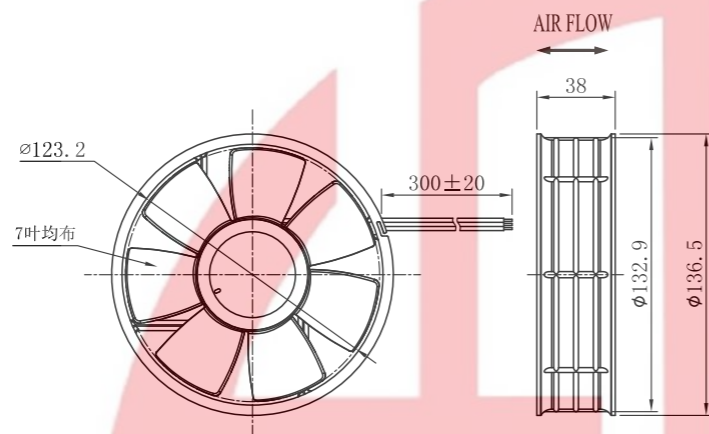

### DC FAN 136\*38MM SERIES

Material  
UL 1007 AWG # 24 OR Equivalent  
Red Wire: Positive (+)  
Black Wire: Negative (-)  
Yellow wire: FG Signal or RD Signal

### P & Q CURVE (AT RATED VOLTAGE)

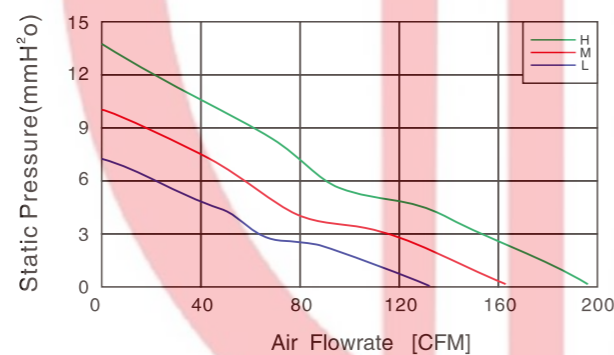

MODEL NO	RATED VOLTAGE V	OPERATING VOLTAGE V	RATED CURRENT A	ACTUAL CURRENT A	RATED POWER	RATED SPEED RPM (±10%)	MAX. AIR FLOW		MAX. STATIC AIR PRESSURE		NOISE LEVEL db(A)
							CMM	CFM	InH <sub>2</sub> O	mmH <sub>2</sub> O	
JL13638H12B	12	6~13.2	1.4	1.2	16.8	3500	5.502	194.3	0.538	13.67	61.4
JL12638M12B	12	6~13.2	0.90	0.75	10.8	3000	4.715	166.5	0.398	10.10	58.1
JL13638L12B	12	6~13.2	0.6	0.45	7.2	2500	3.928	138.7	0.274	6.97	54.1
JL13638H24B	24	12~26.4	1.4	1.2	33.6	3500	5.502	194.3	0.538	13.67	61.4
JL12638M24B	24	12~26.4	0.90	0.75	21.6	3000	4.715	166.5	0.398	10.10	58.1
JL13638L24B	24	12~26.4	0.6	0.45	14.4	2500	3.928	138.7	0.274	6.97	54.1



### DC BLOWER 200\*200\*70MM SERIES

尺寸 Size: Φ200mmx70mm  
风量 Airflow: 335~550CFM  
重量 Weight: 1760g  
噪音 Noise: 58~85dB(A)  
风叶 Impeller Material: PA66  
马达 Motor: DC brushless external rotor Motor  
引线 Lead Wire: AWG#20 UL 1007  
温度范围 Operating Temperature: -25°C~+65°C  
防护等级 Type of protection: IP42  
绝缘等级 Insulation class: "B"

### DIMENSIONS DRAWING

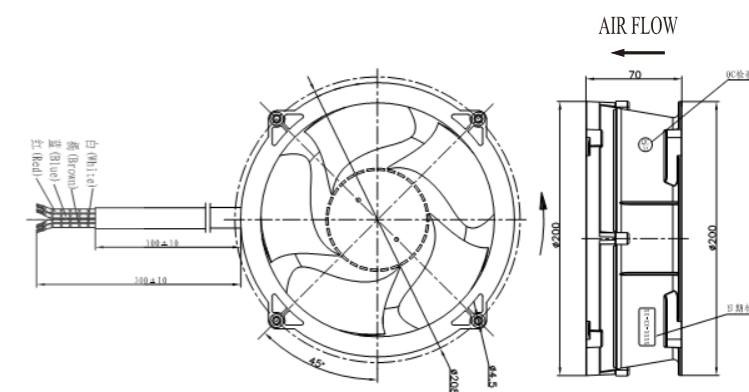

### P & Q CURVE (AT RATED VOLTAGE)

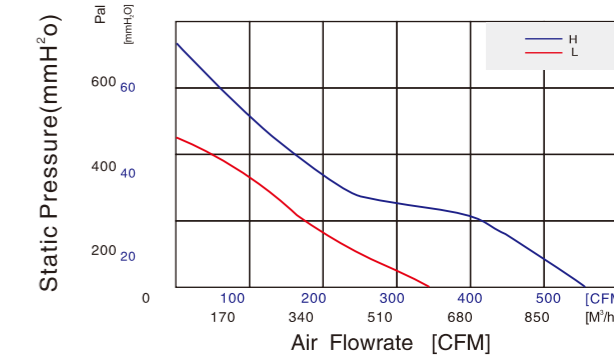

产品型号 Model	轴承型式 Bearing System	电压 Voltage	电压范围 Voltage Range	电流 Current	转速 Speed	风量 Air Flow	静压 Static Pressure	噪音 Noise	可用功能选择 Available Features (Optional)		
Part NO.	B / S / F	VDC	VDC	A	RPM	CFM	mmH <sub>2</sub> O	dB(A)	Tachometer Out put 转速输出	Autorestart 自动重启	Pulse Width Modulation 脉宽调节
JL4820070HB2M	Ball	48	36/56	2.3	4600	550	72.4	85	●	●	●
JL4820070LB2M		48	36/56	0.75	2900	335	21.9	58	●	●	●
JL2420070HB2M		24	16/28	4.5	4600	550	72.4	85	●	●	●

# 九龙电机



JULONG MOTOR  
AC/DC FANS COOLING FANS



本样机仅做造型参考，具体以规格书为准。  
This sample book is for reference only. Please refer to the specification for details.  
如需特殊电压也可根据规格书提供。本公司保留技术知识产权。  
Special voltage may be provided (necessary according to the enquiry). All rights reserved.

Http://www.xtgygs.cn



### DIMENSIONS DRAWING

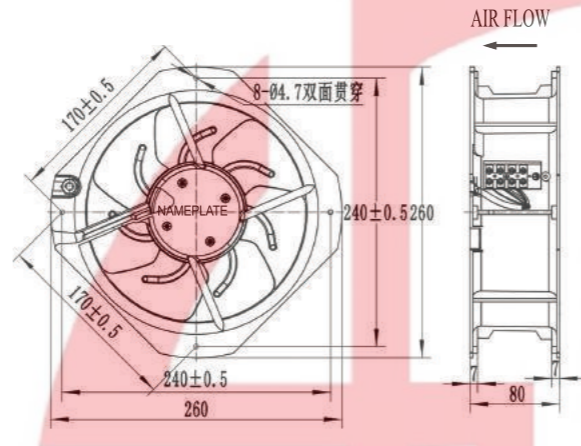

### DC BLOWER 225\*225\*80MM SERIES

尺寸 Size: 225mmx225mmx80mm  
风量 Airflow: 581CFM  
重量 Weight: 2200g  
噪音 Noise: 62dB(A)  
风叶 Impeller Material: Metal  
马达 Motor: DC brushless external rotor Motor  
引线 Lead Wire: AWG#20 UL 1007  
温度范围 Operating Temperature: -25°C~+65°C  
防护等级 Type of protection: IP42  
绝缘等级 Insulation class: "B"

### P & Q CURVE (AT RATED VOLTAGE)

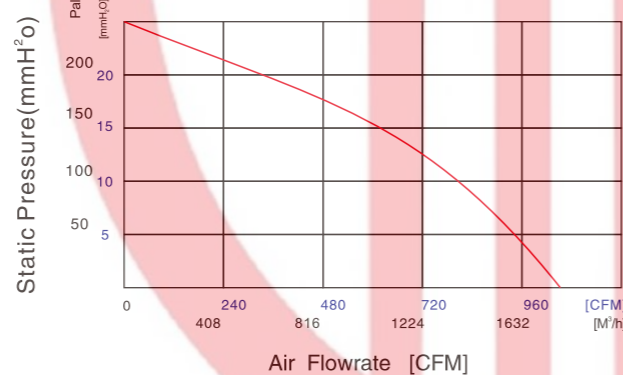

产品型号 Model	轴承型式 Bearing System	电压 Voltage	电压范围 Voltage Range	电流 Current	转速 Speed	风量 Air Flow	静压 Static Pressure	噪音 Noise	可用功能选择 Available Features (Optional)		
Part NO.	B / S / F	VDC	VDC	A	RPM	CFM	mmH <sub>2</sub> O	dB(A)	Tachometer Out put 转速输出	Autorestart 自动重启	Pulse Width Modulation 脉宽调节
JL2422580HB2M	Ball	24	16/28	2.4	2800	581	25.25	62	●	●	●
JL4822580HB2M		48	36/57	1.2	2800	581	25.25	62	●	●	●

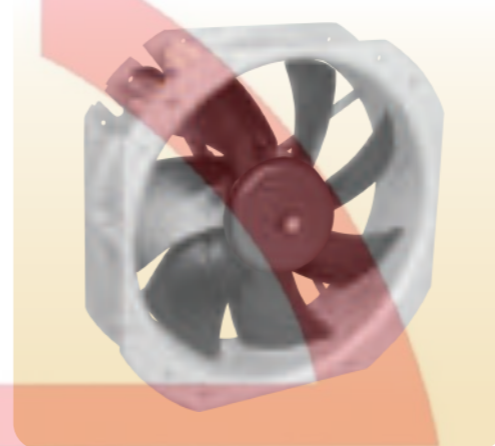
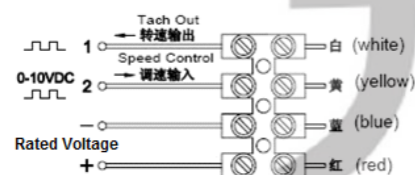

### DIMENSIONS DRAWING

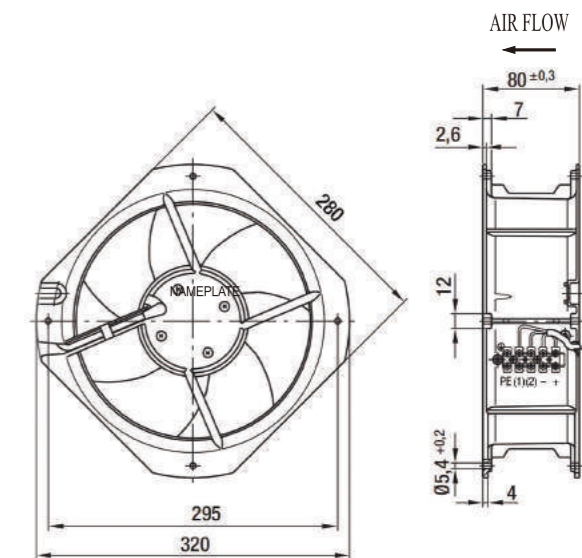

### DC BLOWER 280\*280\*80MM SERIES

尺寸 Size: 280mmx280mmx80mm  
风量 Airflow: 1094CFM  
重量 Weight: 2500g  
噪音 Noise: 70dB(A)  
风叶 Impeller Material: Metal  
马达 Motor: DC brushless external rotor Motor  
引线 Lead Wire: AWG#20 UL 1007  
温度范围 Operating Temperature: -25°C~+65°C  
防护等级 Type of protection: IP42  
绝缘等级 Insulation class: "B"

### P & Q CURVE (AT RATED VOLTAGE)

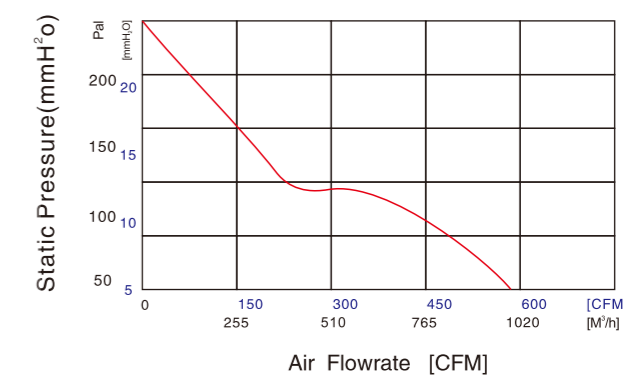

产品型号 Model	轴承型式 Bearing System	电压 Voltage	电压范围 Voltage Range	电流 Current	转速 Speed	风量 Air Flow	静压 Static Pressure	噪音 Noise	可用功能选择 Available Features (Optional)		
Part NO.	B / S / F	VDC	VDC	A	RPM	CFM	mmH <sub>2</sub> O	dB(A)	Tachometer Out put 转速输出	Autorestart 自动重启	Pulse Width Modulation 脉宽调节
JL4828080HB2M	Ball	48	36/56	2.4	2600	1094.2	24.96	68	●	●	●
JL2428080HB2M		24	16/28	4.8	2600	1094.2	24.96	68	●	●	●

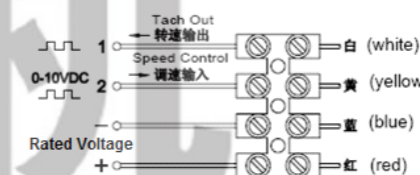

# 九 龙 电 机

AC Axial Fan  
AC轴流风机

AC All-Metal Axial Fan  
AC全金属轴流风扇

DC Axial Fan  
DC轴流风机

DC Centrifugal Fan  
DC离心风机

EC Axial Fan  
EC轴流风机

EC Centrifugal Fan  
EC离心风机

AC Centrifugal Fan  
AC离心风机

Fan Accessories  
风机配件



JULONG MOTOR  
AC/DC FANS COOLING FANS



本样图仅供参考，具体以实物为准。  
This sample book is for reference only. Please refer to the specification for details.  
如需特殊电压也可根据需求提供。本公司保留技术更改权利。  
Special voltage may be provided flexibly according to the requirement. All technical modification rights reserved.

Http://www.xtgygs.cn

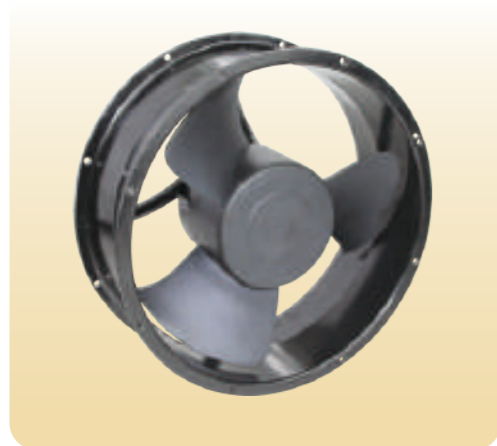

### DIMENSIONS DRAWING

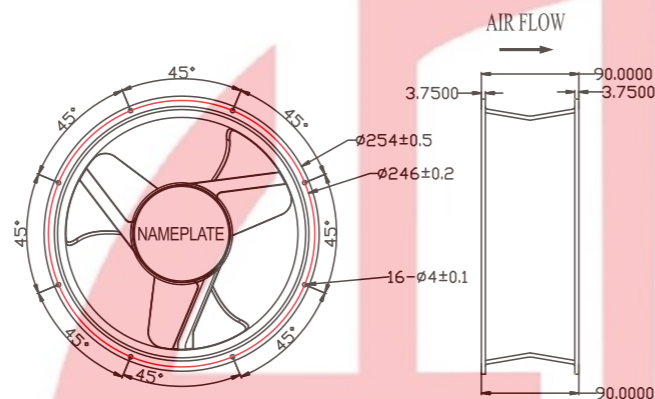

### DC AXIAL FAN Ø254\*89MM SERIES

Material  
Impeller & Frame: plastic(UL94V-0)  
Red Wire Positive(+)  
Black Wire Negative(-)  
Weight: 2600g

### P & Q CURVE (AT RATED VOLTAGE)

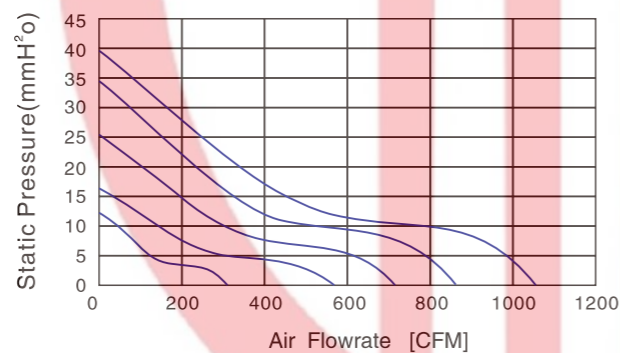

MODEL NO	RATED VOLTAGE V	OPERATING VOLTAGE V	RATED CURRENT A	ACTUAL CURRENT A	RATED POWER	RATED SPEED RPM (±10%)	MAX. AIR FLOW		MAX.STATIC AIR PRESSURE		NOISE LEVEL db(A)
							CMM	CFM	InH2O	mmH2O	
JL25489L12	12	6~13.5	0.75	0.73	9	1000	8.7	194.3	0.538	12.5	51.2
JL25489L24	24	18~26.5	0.5	0.48	12	1000	8.7	166.5	0.398	12.5	51.2
JL25489L48	48	36~56	0.2	0.18	9.6	1000	8.7	138.7	0.274	12.5	51.2
JL25489M12	12	6~13.5	3.5	3.48	42	2000	16	194.3	0.538	16.4	63.8
JL25489M24	24	18~26.5	1.5	1.48	36	2000	16	166.5	0.398	16.4	63.8
JL25489M48	48	36~56	0.8	0.78	38.4	2000	16	138.7	0.274	16.4	63.8
JL25489H24	24	18~26.5	2.9	2.88	69.6	2500	20.3	194.3	0.538	25.5	68.2
JL25489H48	48	36~56	1.8	1.78	86.4	2500	20.3	166.5	0.398	25.5	68.2
JL25489H24-HH	24	18~26.5	4.8	4.78	115.2	3000	24.5	138.7	0.274	34.4	73.5
JL25489H48-HH	48	36~56	2.6	2.58	124.8	3000	24.5	194.3	0.538	34.4	73.5
JL25489H48-VH	48	36~56	3.5	3.48	168	3500	30	166.5	0.398	39.5	78.9



### DIMENSIONS DRAWING

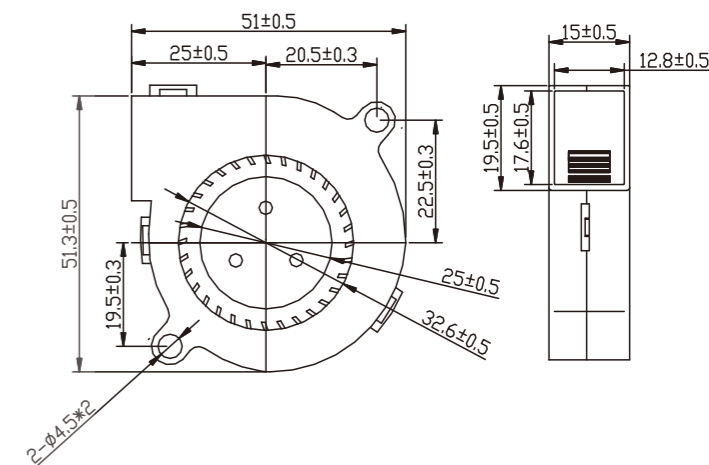

### DC BLOWER 50\*50\*15MM SERIES

Material  
UL 1007 AWG # 24 OR Equivalent  
Red Wire: Positive (+)  
Black Wire: Negative (-)  
Yellow wire: FG or RD Signal

### P & Q CURVE (AT RATED VOLTAGE)

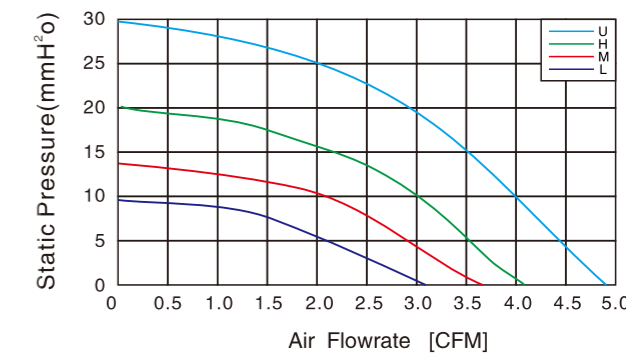

MODEL NO	RATED VOLTAGE V	OPERATING VOLTAGE V	RATED CURRENT A	ACTUAL CURRENT A	RATED POWER	RATED SPEED RPM (±10%)	MAX. AIR FLOW		MAX.STATIC AIR PRESSURE		NOISE LEVEL db(A)
							CMM	CFM	InH2O	mmH2O	
JL5015U12Y	12	6~13.2	0.28	0.25	3.36	7500	0.136	4.82	1.176	29.87	47.9
JL5015H12Y	12	6~13.2	0.17	0.15	2.04	6500	0.116	4.10	0.803	20.40	44.7
JL5015M12Y	12	6~13.2	0.13	0.11	1.56	5500	0.101	3.57	0.556	14.12	40.2
JL5015L12Y	12	6~13.2	0.1	0.08	1.2	4500	0.084	2.97	0.357	9.07	34.9
JL5015U24Y	24	12~26.4	0.16	0.25	3.84	7500	0.136	4.82	1.176	29.87	47.9
JL5015H24Y	24	12~26.4	0.12	0.11	2.88	6500	0.116	4.10	0.803	20.40	44.7
JL5015M24Y	24	12~26.4	0.1	0.09	2.4	5500	0.101	3.57	0.556	14.12	40.2
JL5015L24Y	24	12~26.4	0.08	0.07	1.92	4500	0.084	2.97	0.357	9.07	34.9

■ PS: Where Y can be S . B .



JULONG MOTOR  
AC/DC FANS COOLING FANS



本样图仅供参考，具体以规格书为准。  
This sample book is for reference only. Please refer to the specification for details.  
如需特殊电压也可根据规格书提供。本公司保留技术更改权利。  
Special voltage may be provided flexibly according to the requirement. All technical modification rights reserved.

Http://www.xtgygs.cn

### DIMENSIONS DRAWING

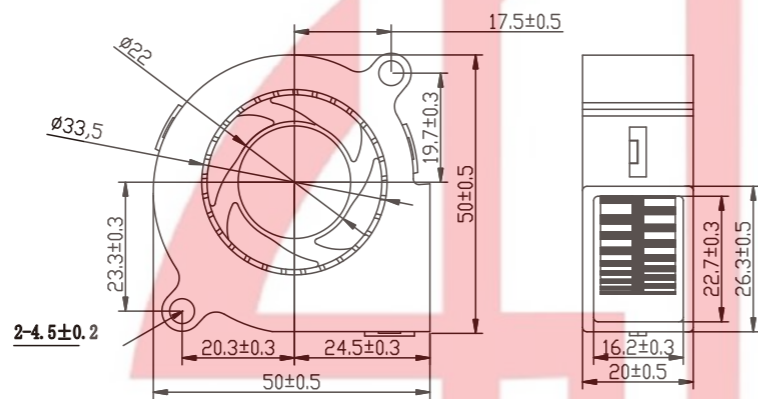

### P & Q CURVE (AT RATED VOLTAGE)

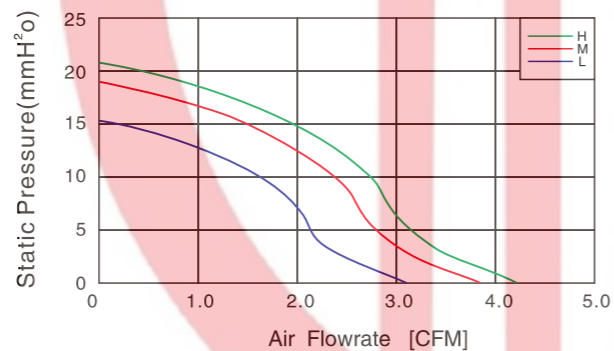

## DC BLOWER 50\*50\*20MM SERIES

Material  
UL 1007 AWG # 24 OR Equivalent  
Red Wire:Positive (+)  
Black Wire:Negative (-)  
Yellow wire:FG Signal or RD Signal

MODEL NO	RATED VOLTAGE V	OPERATING VOLTAGE V	RATED CURRENT A	ACTUAL CURRENT A	RATED POWER	RATED SPEED RPM (±10%)	MAX. AIR FLOW		MAX.STATIC AIR PRESSURE		NOISE LEVEL db(A)
							CMM	CFM	InH <sub>2</sub> O	mmH <sub>2</sub> O	
JL5020L5	5	3.6~6.8	0.17	0.15	0.85	4000	0.081	3.09	0.599	15.222	32.1
JL5020L12	12	6~13.5	0.14	0.12	1.68	4000	0.081	3.09	0.599	15.222	32.1
JL5020L24	24	18~26.5	0.07	0.05	1.68	4000	0.081	3.09	0.599	15.222	32.1
JL5020M5	5	3.6~6.8	0.39	0.37	1.95	5000	0.109	3.87	0.749	19.028	37
JL5020M12	12	6~13.5	0.19	0.17	2.28	5000	0.109	3.87	0.749	19.028	37
JL5020M24	24	18~26.5	0.11	0.09	2.64	5000	0.109	3.87	0.749	19.028	37
JL5020H12	12	6~13.5	0.23	0.21	2.76	5500	0.121	4.26	0.824	20.931	39.6
JL5020H24	24	18~26.5	0.15	0.13	3.6	5500	0.121	4.26	0.824	20.931	39.6

### DIMENSIONS DRAWING

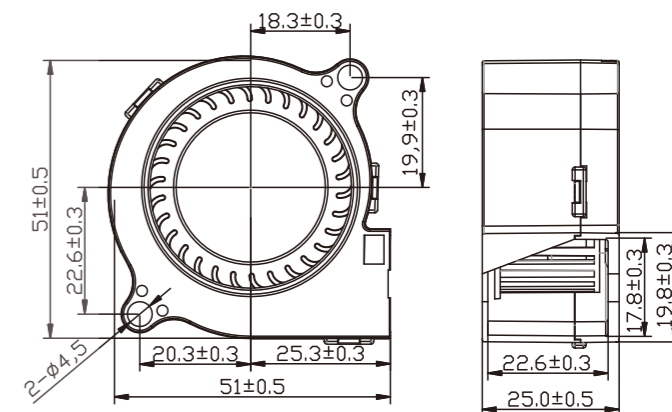
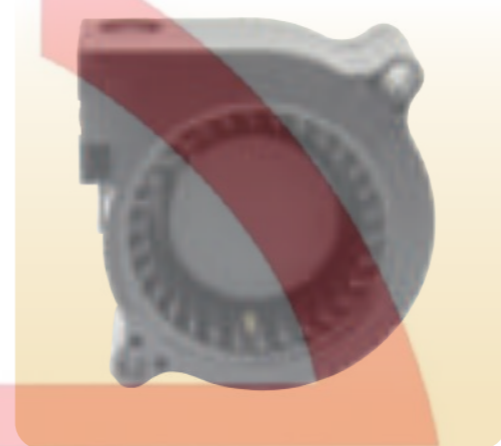

### P & Q CURVE (AT RATED VOLTAGE)

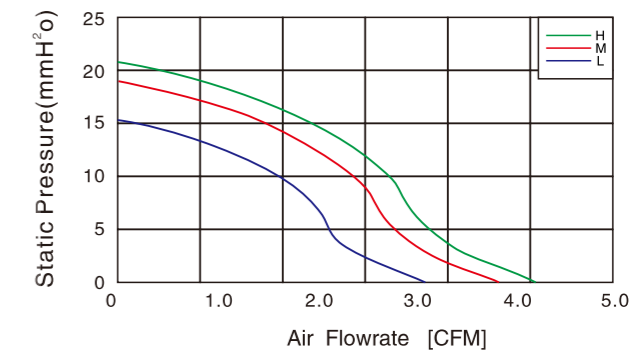

## DC BLOWER 50\*50\*25MM SERIES

Material  
UL 1007 AWG # 22 OR Equivalent  
Red Wire:Positive (+)  
Black Wire:Negative (-)  
Yellow wire:FG or RD Signal

MODEL NO	RATED VOLTAGE V	OPERATING VOLTAGE V	RATED CURRENT A	ACTUAL CURRENT A	RATED POWER	RATED SPEED RPM (±10%)	MAX. AIR FLOW		MAX.STATIC AIR PRESSURE		NOISE LEVEL db(A)
							CMM	CFM	InH <sub>2</sub> O	mmH <sub>2</sub> O	
JL5025L05	5	3.6~6.8	0.16	0.14	0.8	3000	0.087	3.09	0.599	5.222	34.5
JL5025L12	12	6.0~13.5	0.11	0.09	1.32	3000	0.087	3.09	0.599	5.222	34.5
JL5025M05	5	3.6~6.8	0.21	0.19	1.05	3500	0.105	3.727	0.301	7.623	37.5
JL5025M12	12	6.0~13.5	0.14	0.12	1.68	3500	0.105	3.727	0.301	7.623	37.5
JL5025M24	24	18~26.5	0.08	0.06	1.92	3500	0.105	3.727	0.301	7.623	37.5
JL5025H05	5	3.6~6.8	0.35	0.33	1.75	4000	0.113	3.993	0.442	11.24	40.3
JL5025H12	12	6.0~13.5	0.2	0.18	2.4	4000	0.113	3.993	0.442	11.24	40.3
JL5025H24	24	18~26.5	0.1	0.08	2.4	4000	0.113	3.993	0.442	11.24	40.3
JL5025H12-HH	12	6.0~13.5	0.25	0.23	3	5000	0.151	5.305	0.819	20.801	46.2
JL5025H24-HH	24	18~26.5	0.12	0.10	2.88	5000	0.151	5.305	0.819	20.801	46.2

AC Axial Fan  
AC轴流风机

AC All-Metal Axial Fan  
AC全金属轴流风扇

DC Axial Fan  
DC轴流风机

DC Centrifugal Fan  
DC离心风机

EC Axial Fan  
EC轴流风机

EC Centrifugal Fan  
EC离心风机

AC Centrifugal Fan  
AC离心风机

Fan Accessories  
风机配件



JULONG MOTOR  
AC/DC FANS COOLING FANS



本样册仅供参考，具体以规格书为准。  
This sample book is for reference only. Please refer to the specification for details.  
如需特殊电压也可特别定制提供。本公司保留技术知识产权。  
Special voltage may be provided flexibly according to the requirement. All technical modification rights reserved.

Http://www.xtgygs.cn

### DIMENSIONS DRAWING

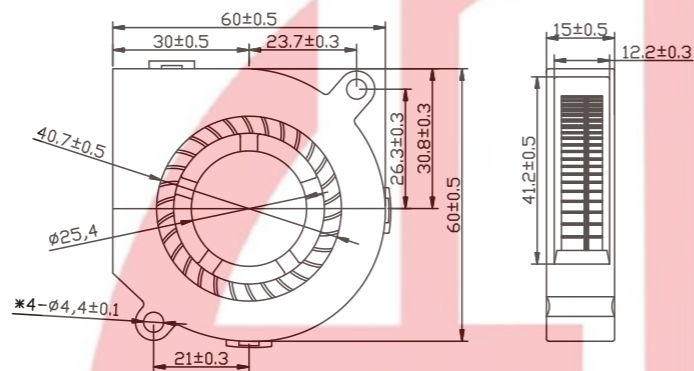

### P & Q CURVE (AT RATED VOLTAGE)

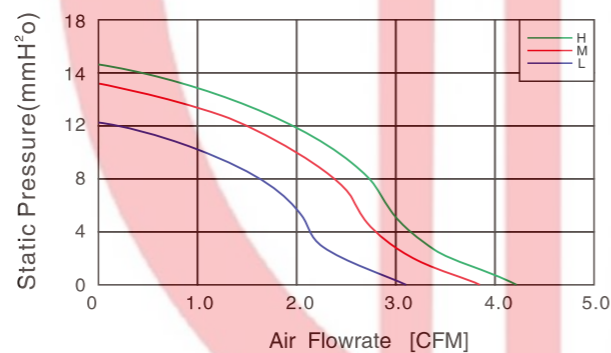

### DC BLOWER 60\*60\*15MM SERIES

Material  
UL 1007 AWG # 24 OR Equivalent  
Red Wire:Positive (+)  
Black Wire:Negative (-)  
Yellow wire:FG Signal or RD Signal

MODEL NO	RATED VOLTAGE V	OPERATING VOLTAGE V	RATED CURRENT A	ACTUAL CURRENT A	RATED POWER	RATED SPEED RPM (±10%)	MAX. AIR FLOW		MAX.STATIC AIR PRESSURE		NOISE LEVEL db(A)
							CMM	CFM	InH <sub>2</sub> O	mmH <sub>2</sub> O	
JL6015L05	5	3.6~6.8	0.16	0.14	0.8	3500	0.1	3.55	0.43	10.8	33.4
JL6015L12	12	6.0~13.5	0.13	0.11	1.56	3500	0.1	3.55	0.43	10.8	33.4
JL6015M12	12	3.6~6.8	0.2	0.18	2.4	4000	0.11	3.85	0.45	11.5	37.9
JL6015M24	24	6.0~13.5	0.12	0.10	2.88	4000	0.11	3.85	0.45	11.5	37.9
JL6015H12	12	3.6~6.8	0.28	0.26	3.36	4500	0.12	4.45	0.61	15.53	40.6
JL6015H24	24	6.0~13.5	0.15	0.13	3.6	4500	0.12	4.45	0.61	15.53	40.6

### DIMENSIONS DRAWING

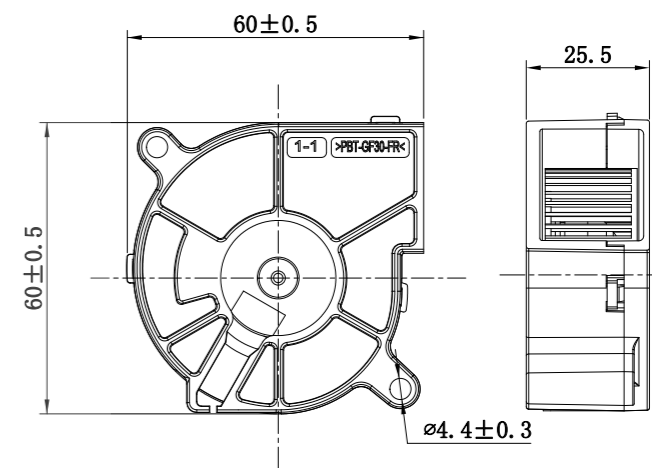
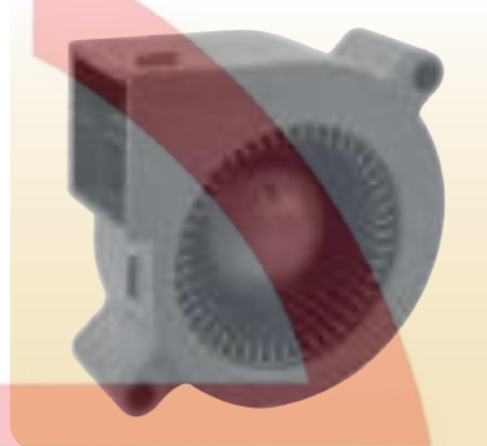

### P & Q CURVE (AT RATED VOLTAGE)

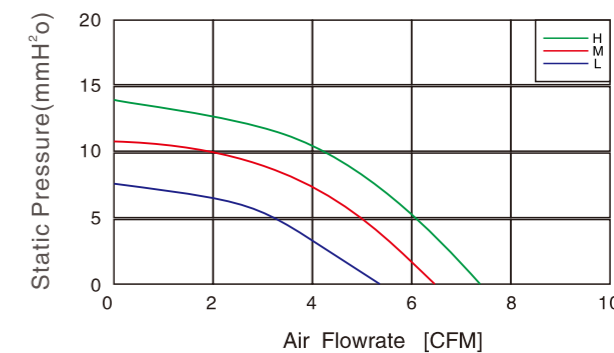

### DC BLOWER 60\*60\*25MM SERIES

Material  
UL 1007 AWG # 24 OR Equivalent  
Red Wire:Positive (+)  
Black Wire:Negative (-)  
Yellow wire:FG or RD Signal

MODEL NO	RATED VOLTAGE V	OPERATING VOLTAGE V	RATED CURRENT A	ACTUAL CURRENT A	RATED POWER	RATED SPEED RPM (±10%)	MAX. AIR FLOW		MAX.STATIC AIR PRESSURE		NOISE LEVEL db(A)
							CMM	CFM	InH <sub>2</sub> O	mmH <sub>2</sub> O	
JL6025H12B	12	6~13.2	0.28	0.25	3.36	4000	0.206	7.28	0.585	14.87	35.5
JL6025M12B	12	6~13.2	0.18	0.16	2.16	3500	0.180	6.37	0.449	11.4	32.6
JL6025L12B	12	6~13.2	0.14	0.12	1.68	3000	0.155	5.46	0.330	8.37	29.3
JL6025H24B	24	12~26.4	0.16	0.14	3.84	4000	0.206	7.28	0.585	14.87	35.5
JL6025M24B	24	12~26.4	0.14	0.10	3.36	3500	0.180	6.37	0.449	11.4	32.6
JL6025L24B	24	12~26.4	0.1	0.07	2.4	3000	0.155	5.46	0.330	8.37	29.3

# 九 龙 电 机



JULONG MOTOR  
AC/DC FANS COOLING FANS



本样册仅供参考，具体以规格书为准。  
This sample book is for reference only. Please refer to the specification for details.  
如需特殊电压也可特别定制提供。本公司保留技术知识产权。  
Special voltage may be provided according to the requirement. All technical modification rights reserved.

Http://www.xtgygs.cn



### DIMENSIONS DRAWING

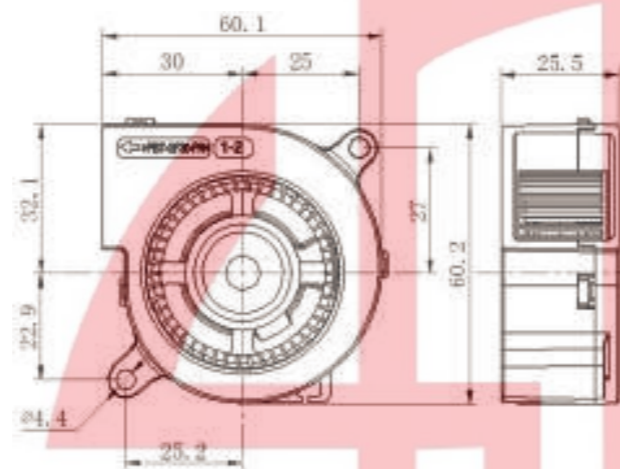

### P & Q CURVE (AT RATED VOLTAGE)

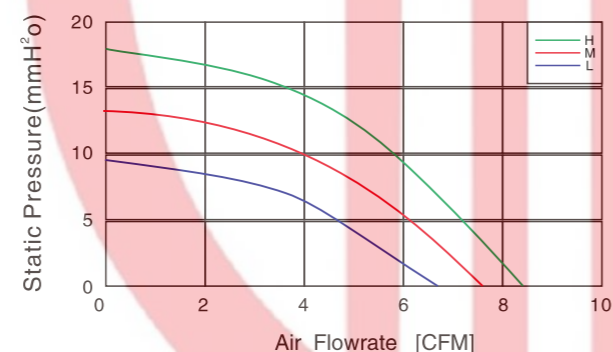

## DC BLOWER 60\*60\*25MM SERIES

Material  
UL 1007 AWG # 24 OR Equivalent  
Red Wire: Positive (+)  
Black Wire: Negative (-)  
Yellow wire: FG or RD Signal

MODEL NO	RATED VOLTAGE V	OPERATING VOLTAGE V	RATED CURRENT A	ACTUAL CURRENT A	RATED POWER	RATED SPEED RPM (±10%)	MAX. AIR FLOW		MAX. STATIC AIR PRESSURE		NOISE LEVEL db(A)
							CMM	CFM	InH <sub>2</sub> O	mmH <sub>2</sub> O	
JL6025H12B	12	6~13.2	0.30	0.27	3.6	4000	0.240	8.46	0.689	17.5	36.1
JL6025M12B	12	6~13.2	0.20	0.18	2.4	3500	0.210	7.40	0.528	13.4	33.2
JL6025L12B	12	6~13.2	0.15	0.13	1.8	3000	0.180	6.35	0.387	9.84	32.6
JL6025H24B	24	12~26.4	0.18	0.15	4.32	4000	0.240	8.46	0.689	17.5	36.1
JL6025M24B	24	12~26.4	0.15	0.10	3.6	3500	0.210	7.40	0.528	13.4	33.2
JL6025L24B	24	12~26.4	0.1	0.07	2.4	3000	0.180	6.35	0.387	9.84	32.6



### DIMENSIONS DRAWING

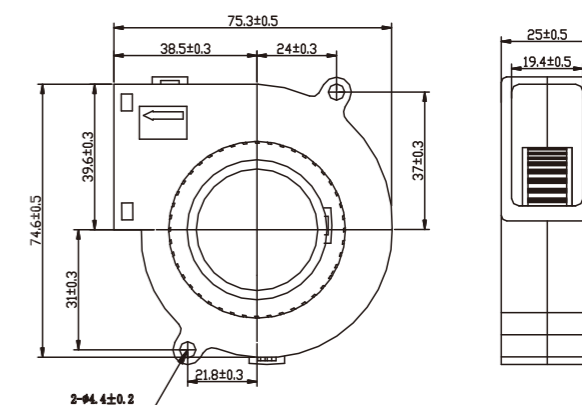

## DC BLOWER 75.3\*75.3\*25MM SERIES

Material  
UL 1007 AWG # 22 OR Equivalent  
Red Wire: Positive (+)  
Black Wire: Negative (-)  
Yellow wire: FG or RD Signal

### P & Q CURVE (AT RATED VOLTAGE)

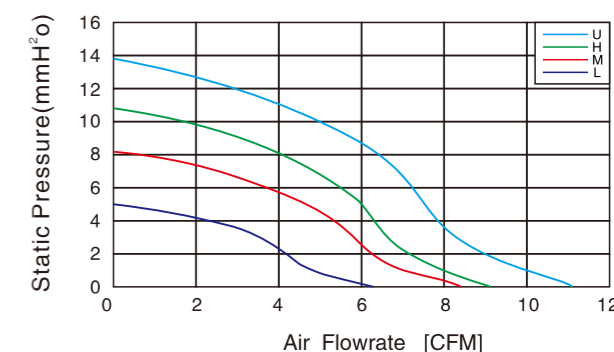

MODEL NO	RATED VOLTAGE V	OPERATING VOLTAGE V	RATED CURRENT A	ACTUAL CURRENT A	RATED POWER	RATED SPEED RPM (±10%)	MAX. AIR FLOW		MAX. STATIC AIR PRESSURE		NOISE LEVEL db(A)
							CMM	CFM	InH <sub>2</sub> O	mmH <sub>2</sub> O	
JL7525L12	12	6~13.5	0.11	0.09	1.32	2000	0.18	6.31	0.2	5.04	34.8
JL7525L24	24	18~26.5	0.08	0.06	1.92	2000	0.18	6.31	0.2	5.04	34.8
JL7525M12	12	6~13.5	0.22	0.20	2.64	2500	0.24	8.5	0.32	8.25	36.5
JL7525M24	24	18~26.5	0.11	0.09	2.64	2500	0.24	8.5	0.32	8.25	36.5
JL7525H12	12	6~13.5	0.26	0.24	3.12	3000	0.26	9.21	0.43	10.85	40.1
JL7525H24	24	18~26.5	0.14	0.12	2.94	3000	0.26	9.21	0.43	10.85	40.1
JL7525H12-HH	12	6~13.5	0.35	0.33	4.2	3500	0.31	11.11	0.54	13.75	43.8
JL7525H24-HH	24	18~26.5	0.23	0.21	5.52	3500	0.31	11.11	0.54	13.75	43.8

# 九 龙 电 机

AC Axial Fan  
AC轴流风机

AC All-Metal Axial Fan  
AC全金属轴流风扇

DC Axial Fan  
DC轴流风机

DC Centrifugal Fan  
DC离心风机

EC Axial Fan  
EC轴流风机

EC Centrifugal Fan  
EC离心风机

AC Centrifugal Fan  
AC离心风机

Fan Accessories  
风机配件



JULONG MOTOR  
AC/DC FANS COOLING FANS



### DIMENSIONS DRAWING

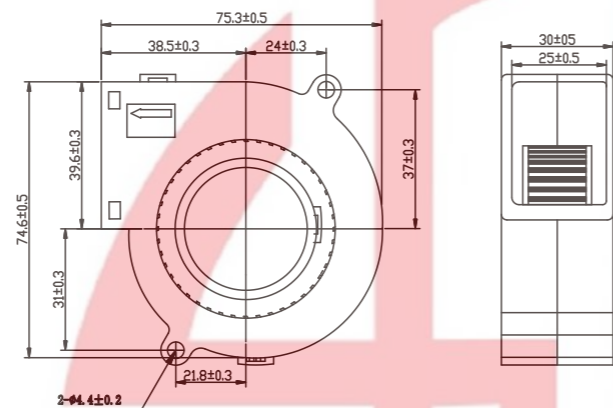

### P & Q CURVE (AT RATED VOLTAGE)

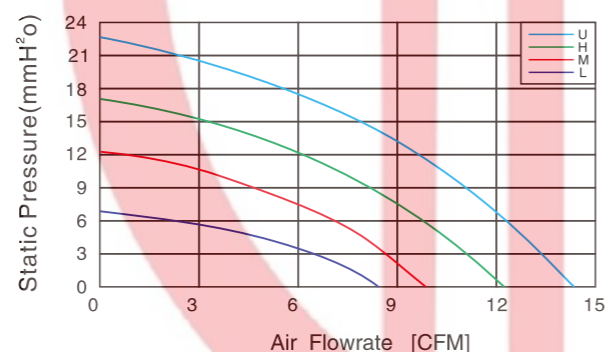

## DC BLOWER 75.3\*75.3\*30MM SERIES

Material  
UL 1007 AWG # 24 OR Equivalent  
Red Wire:Positive (+)  
Black Wire:Negative (-)  
Yellow wire:FG Signal or RD Signal

MODEL NO	RATED VOLTAGE V	OPERATING VOLTAGE V	RATED CURRENT A	ACTUAL CURRENT A	RATED POWER	RATED SPEED RPM (±10%)	MAX. AIR FLOW		MAX.STATIC AIR PRESSURE		NOISE LEVEL db(A)
							CMM	CFM	InH2O	mmH2O	
JL7530U12B	12	6~13.2	0.56	0.51	6.72	4000	0.398	14.06	0.904	22.96	44.6
JL7530H12B	12	6~13.2	0.4	0.36	4.8	3500	0.36	12.71	0.693	17.60	40.4
JL5015M12B	12	6~13.2	0.25	0.23	3	3000	0.301	10.63	0.509	12.93	36.1
JL5015L12B	12	6~13.2	0.17	0.15	2.04	2500	0.247	8.72	0.289	7.34	31.1
JL7530U24B	24	12~26.4	0.34	0.3	8.16	4000	0.398	14.06	0.904	22.96	44.6
JL7530H24B	24	12~26.4	0.26	0.23	6.24	3500	0.36	12.71	0.693	17.60	40.4
JL7530M24B	24	12~26.4	0.16	0.14	3.84	3000	0.301	10.63	0.509	12.93	36.1
JL7530L24B	24	12~26.4	0.12	0.1	2.88	2500	0.247	8.72	0.289	7.34	31.1
JL7530U48B	48	24~52.8	0.25	0.22	12	4000	0.398	14.06	0.904	22.96	44.6
JL7530H48B	48	24~52.8	0.17	0.15	8.16	3500	0.36	12.71	0.693	17.60	40.4
JL7530M48B	48	24~52.8	0.13	0.11	6.24	3000	0.301	10.63	0.509	12.93	36.1
JL7530L48B	48	24~52.8	0.1	0.08	4.8	2500	0.247	8.72	0.289	7.34	31.1



### DIMENSIONS DRAWING

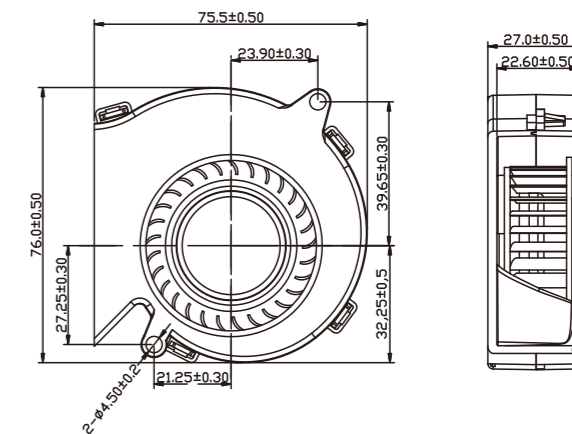

### P & Q CURVE (AT RATED VOLTAGE)

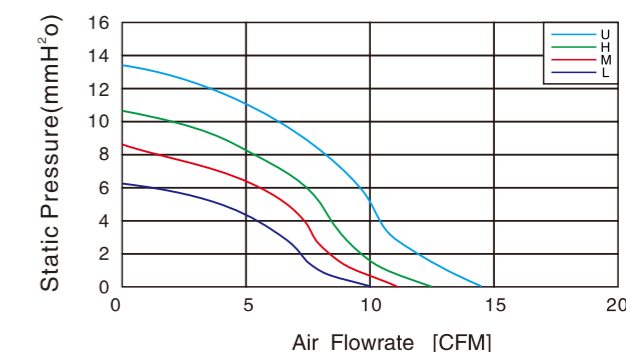

## DC BLOWER 75.5\*76\*27MM SERIES

Material  
UL 1007 AWG # 22 OR Equivalent  
Red Wire:Positive (+)  
Black Wire:Negative (-)  
Yellow wire:FG or RD Signal

MODEL NO	RATED VOLTAGE V	OPERATING VOLTAGE V	RATED CURRENT A	ACTUAL CURRENT A	RATED POWER	RATED SPEED RPM (±10%)	MAX. AIR FLOW		MAX.STATIC AIR PRESSURE		NOISE LEVEL db(A)
							CMM	CFM	InH2O	mmH2O	
JL7627L12	12	6~13.5	0.13	0.11	1.56	3000	0.29	10.23	0.246	6.25	36.2
JL7627L24	24	18~26.5	0.08	0.06	1.92	3000	0.29	10.23	0.246	6.25	36.2
JL7627M12	12	6~13.5	0.22	0.20	2.64	3500	0.32	11.35	0.339	8.6	41.5
JL7627M24	24	18~26.5	0.12	0.10	2.88	3500	0.32	11.35	0.339	8.6	41.5
JL7627H12	12	6~13.5	0.28	0.26	3.36	4000	0.35	12.48	0.421	10.7	45.7
JL7627H24	24	18~26.5	0.15	0.13	3.6	4000	0.35	12.48	0.421	10.7	45.7
JL7627H12-HH	12	6~13.5	0.36	0.34	4.32	4500	0.41	14.63	0.529	13.43	48.1
JL7627H24-HH	24	18~26.5	0.21	0.19	5.04	4500	0.41	14.63	0.529	13.43	48.1

Http://www.xtgygs.cn



JULONG MOTOR  
AC/DC FANS COOLING FANS



本样机仅供参考，具体以规格书为准。  
This sample book is for reference only. Please refer to the specification for details.  
如需特殊电压也可根据规格书提供。本公司保留技术更改权利。  
Special voltage may be provided according to the requirement. All technical modification rights reserved.

Http://www.xtgygs.cn



### DIMENSIONS DRAWING

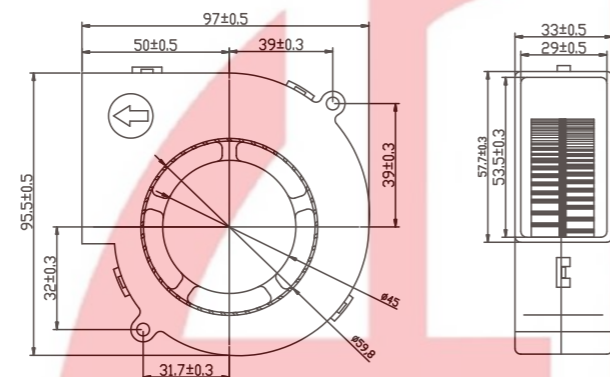

### P & Q CURVE (AT RATED VOLTAGE)

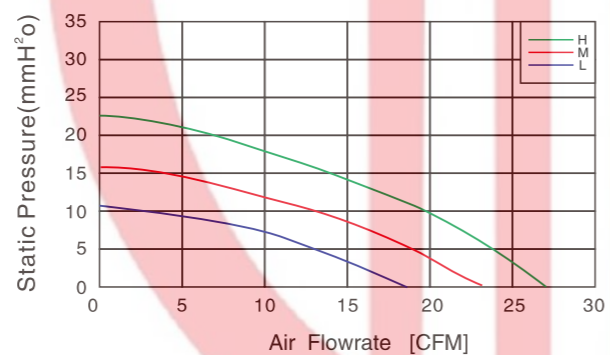

## DC BLOWER 97\*95\*33MM SERIES

Material  
UL 1007 AWG # 24 OR Equivalent  
Red Wire:Positive (+)  
Black Wire:Negative (-)  
Yellow wire:FG Signal or RD Signal

MODEL NO	RATED VOLTAGE V	OPERATING VOLTAGE V	RATED CURRENT A	ACTUAL CURRENT A	RATED POWER	RATED SPEED RPM (±10%)	MAX. AIR FLOW		MAX.STATIC AIR PRESSURE		NOISE LEVEL db(A)
							CMM	CFM	InH2O	mmH2O	
JL9733H12B	12	6~13.2	1.0	0.9	12.0	3500	0.76	26.84	0.893	22.68	50.2
JL9733M12B	12	6~13.2	0.59	0.53	7.08	3000	0.657	23.20	0.656	16.67	46.8
JL9733L12B	12	6~13.2	0.33	0.29	3.96	2500	0.509	17.98	0.457	11.6	42.8
JL9733H24B	24	12~26.4	0.57	0.51	13.7	3500	0.76	26.84	0.893	22.68	50.2
JL9733M24B	24	12~26.4	0.39	0.35	9.36	3000	0.657	23.20	0.656	16.67	46.8
JL9733L24B	24	12~26.4	0.22	0.19	5.28	2500	0.509	17.98	0.457	11.6	42.8
JL9733H48B	48	24~52.8	0.33	0.3	15.8	3500	0.76	26.84	0.893	22.68	50.2
JL9733M48B	48	24~52.8	0.22	0.19	10.6	3000	0.657	23.20	0.656	16.67	46.8
JL9733L48B	48	24~52.8	0.13	0.11	6.24	2500	0.509	17.98	0.457	11.6	42.8

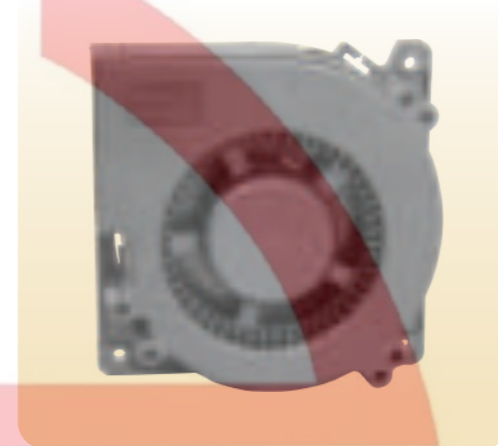

### DIMENSIONS DRAWING

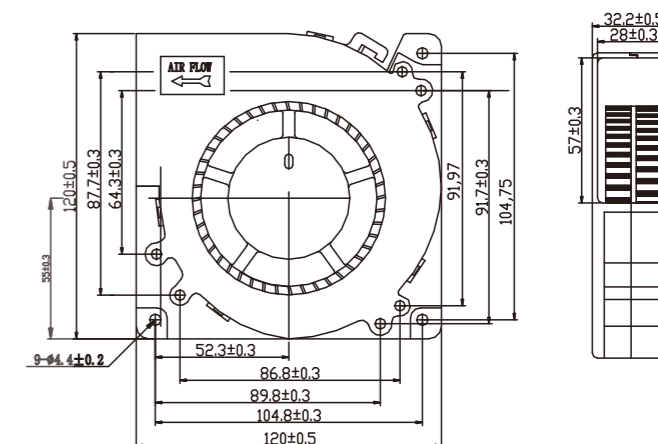

### P & Q CURVE (AT RATED VOLTAGE)

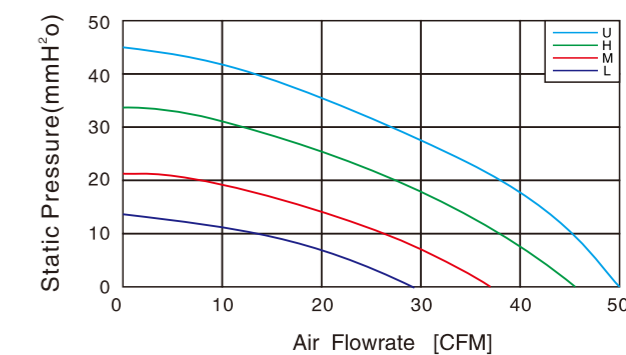

## DC BLOWER 120\*120\*32MM SERIES

Material  
UL 1007 AWG # 24 OR Equivalent  
Red Wire:Positive (+)  
Black Wire:Negative (-)  
Yellow wire:FG or RD Signal

MODEL NO	RATED VOLTAGE V	OPERATING VOLTAGE V	RATED CURRENT A	ACTUAL CURRENT A	RATED POWER	RATED SPEED RPM (±10%)	MAX. AIR FLOW		MAX.STATIC AIR PRESSURE		NOISE LEVEL db(A)
							CMM	CFM	InH2O	mmH2O	
JL12032U12B	12	6~13.2	1.5	1.3	12.0	3500	1.453	51.30	1.799	45.69	57.4
JL12032H12B	12	6~13.2	1.1	1.0	13.2	3000	1.246	44.00	1.295	32.89	54.1
JL12032M12B	12	6~13.2	0.7	0.63	8.40	2500	1.038	36.67	0.899	22.84	50.1
JL12032L12B	12	6~13.2	0.38	0.34	4.56	2000	0.830	29.30	0.575	14.6	45.3
JL12032U24B	24	12~26.4	1.1	1.0	26.4	3500	1.453	51.30	1.799	45.69	57.4
JL12032H24B	24	12~26.4	0.9	0.81	21.6	3000	1.246	44.00	1.295	32.89	54.1
JL12032M24B	24	12~26.4	0.33	0.3	7.92	2500	1.038	36.67	0.899	22.84	50.1
JL12032L24B	24	12~26.4	0.22	0.2	5.28	2000	0.830	29.30	0.575	14.6	45.3
JL12032U48B	48	24~52.8	0.9	0.83	43.2	3500	1.453	51.30	1.799	45.69	57.4
JL12032H48B	48	24~52.8	0.76	0.69	36.5	3000	1.246	44.00	1.295	32.89	54.1
JL12032M48B	48	24~52.8	0.22	0.2	10.6	2500	1.038	36.67	0.899	22.84	50.1
JL12032L48B	48	24~52.8	0.15	0.13	7.2	2000	0.830	29.3	0.575	14.6	45.3

AC Axial Fan  
AC轴流风机

AC All-Metal Axial Fan  
AC全金属轴流风扇

DC Axial Fan  
DC轴流风机

DC Centrifugal Fan  
DC离心风机

EC Axial Fan  
EC轴流风机

EC Centrifugal Fan  
EC离心风机

AC Centrifugal Fan  
AC离心风机

Fan Accessories  
风机配件



JULONG MOTOR  
AC/DC FANS COOLING FANS



Http://www.xtgygs.cn



### DIMENSIONS DRAWING

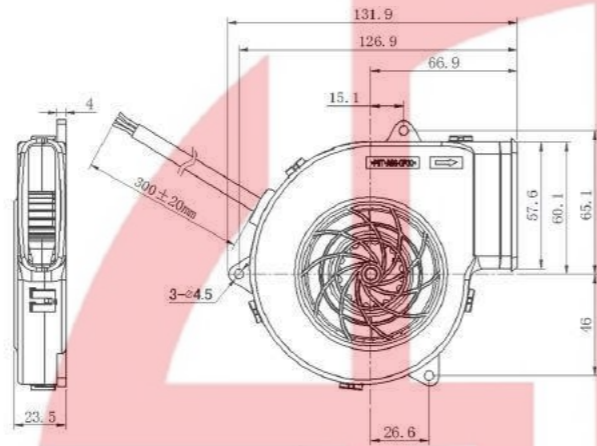

### DC BLOWER 130\*121\*25MM SERIES

Material  
UL 1007 AWG # 24 OR Equivalent  
Red Wire:Positive (+)  
Black Wire:Negative (-)  
Yellow wire:FG Signal or RD Signal

### P & Q CURVE (AT RATED VOLTAGE)

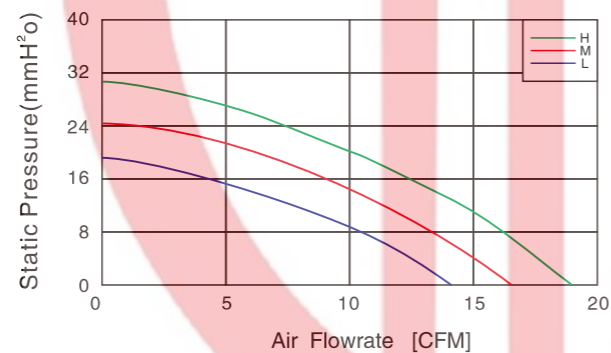

MODEL NO	RATED VOLTAGE V	OPERATING VOLTAGE V	RATED CURRENT A	ACTUAL CURRENT A	RATED POWER	RATED SPEED RPM (±10%)	MAX. AIR FLOW		MAX.STATIC AIR PRESSURE		NOISE LEVEL db(A)
							CMM	CFM	InH <sub>2</sub> O	mmH <sub>2</sub> O	
JL13025H12B	12	6~13.2	0.6	0.5	7.2	3200	0.512	18.07	1.189	30.20	50.8
JL13025M12B	12	6~13.2	0.42	0.37	5.04	2900	0.464	16.38	0.976	24.80	48.6
JL13025L12B	12	6~13.2	0.3	0.25	3.60	2500	0.400	14.12	0.726	18.43	45.4



### DIMENSIONS DRAWING

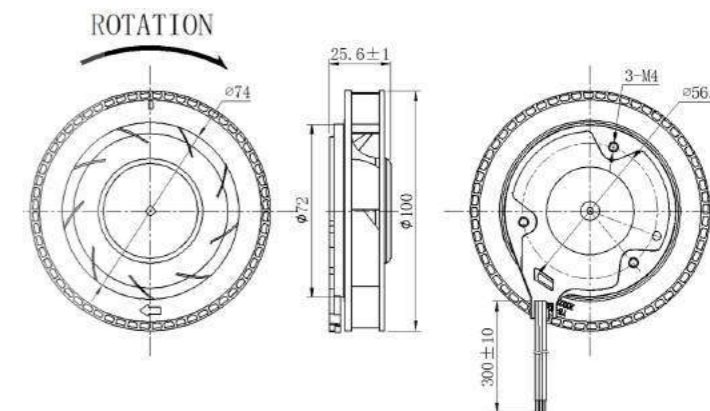

### DC ENTRIFUGAL FAN 100\*100\*25MM SERIES

Material  
UL 1007 AWG # 24 OR Equivalent  
Red Wire:Positive (+)  
Black Wire:Negative (-)  
Yellow wire:FG or RD Signal

### P & Q CURVE (AT RATED VOLTAGE)

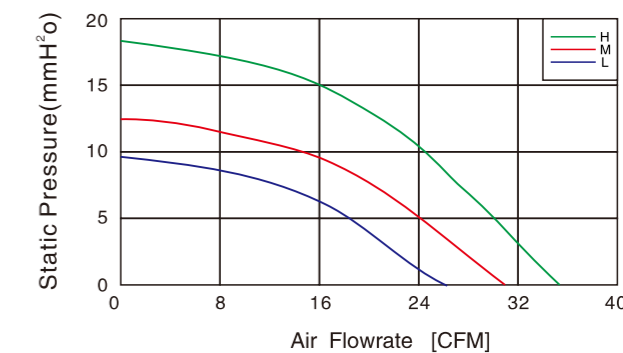

MODEL NO	RATED VOLTAGE V	OPERATING VOLTAGE V	RATED CURRENT A	ACTUAL CURRENT A	RATED POWER	RATED SPEED RPM (±10%)	MAX. AIR FLOW		MAX.STATIC AIR PRESSURE		NOISE LEVEL db(A)
							CMM	CFM	InH <sub>2</sub> O	mmH <sub>2</sub> O	
YDH10025H12B	12	6~13.2	0.15	0.13	1.8	3500	0.989	34.91	0.736	18.7	43.5
YDH10025M12B	12	6~13.2	0.25	0.22	3.0	3000	0.875	30.9	0.539	13.7	40.1
YDH10025L12B	12	6~13.2	0.30	0.25	3.6	2500	0.705	24.9	0.376	9.54	36.2
YDH10025H24B	24	12~26.4	0.10	0.09	2.4	3500	0.989	34.91	0.736	18.7	43.5
YDH10025M24B	24	12~26.4	0.15	0.13	3.6	3000	0.875	30.9	0.539	13.7	40.1
YDH10025L24B	24	12~26.4	0.20	0.18	4.8	2500	0.705	24.9	0.375	9.54	36.2

# 九 龙 电 机

AC Axial Fan  
AC轴流风机

AC All-Metal Axial Fan  
AC全金属轴流风扇

DC Axial Fan  
DC轴流风机

DC Centrifugal Fan  
DC离心风机

EC Axial Fan  
EC轴流风机

EC Centrifugal Fan  
EC离心风机

AC Centrifugal Fan  
AC离心风机

Fan Accessories  
风机配件



JULONG MOTOR  
AC/DC FANS COOLING FANS



Http://www.xtgygs.cn



### DIMENSIONS DRAWING

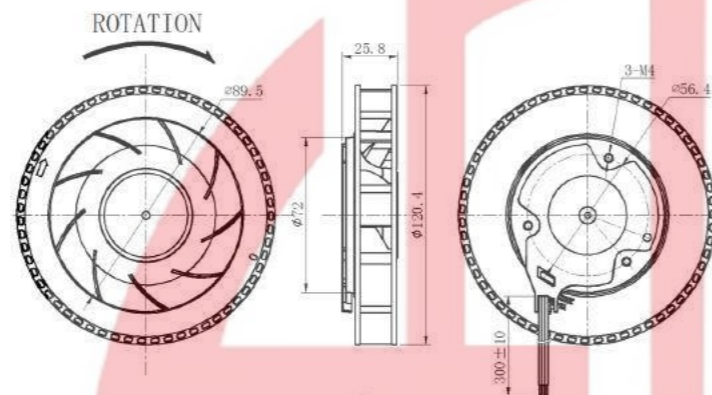

### P & Q CURVE (AT RATED VOLTAGE)

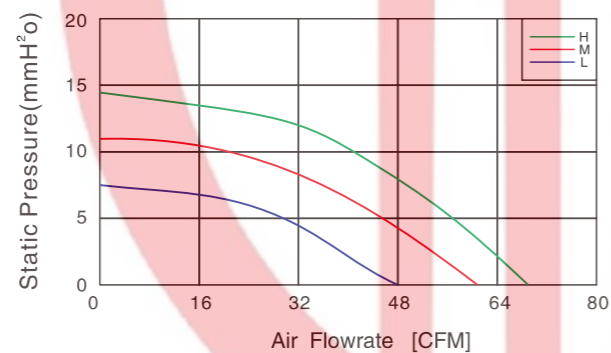

## DC ENTRIFUGAL FAN 120\*120\*25MM SERIES

Material  
UL 1007 AWG # 24 OR Equivalent  
Red Wire:Positive (+)  
Black Wire:Negative (-)  
Yellow wire:FG Signal or RD Signal

MODEL NO	RATED VOLTAGE V	OPERATING VOLTAGE V	RATED CURRENT A	ACTUAL CURRENT A	RATED POWER	RATED SPEED RPM (±10%)	MAX. AIR FLOW		MAX.STATIC AIR PRESSURE		NOISE LEVEL db(A)
							CMM	CFM	InH2O	mmH2O	
YDH12025H12B	12	6~13.2	0.8	0.72	9.6	3500	1.860	65.70	0.583	14.80	55.1
YDH12025M12B	12	6~13.2	0.6	0.56	7.2	3000	1.594	56.30	0.429	10.90	51.8
YDH12025L12B	12	6~13.2	0.4	0.37	4.8	2500	1.328	46.90	0.299	7.60	47.8
YDH12025H24B	24	12~26.4	0.45	0.42	10.8	3500	1.860	65.70	0.583	14.80	55.1
YDH12025M24B	24	12~26.4	0.3	0.28	7.2	3000	1.594	56.30	0.429	10.90	51.8
YDH12025L24B	24	12~26.4	0.25	0.22	6	2500	1.328	46.90	0.299	7.60	47.8



### DIMENSIONS DRAWING

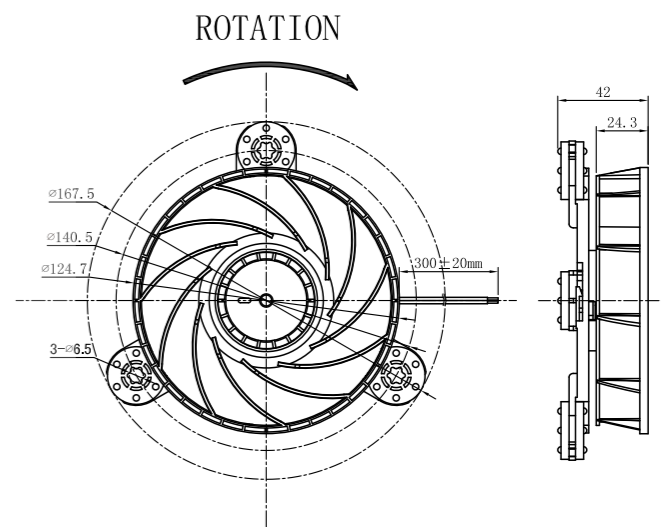

### P & Q CURVE (AT RATED VOLTAGE)

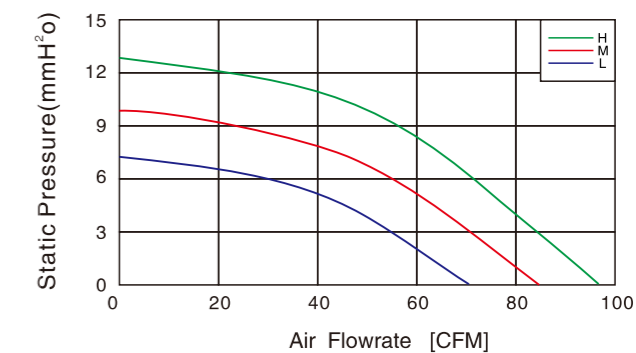

## DC ENTRIFUGAL FAN 120\*120\*35MM SERIES

Material  
UL 1007 AWG # 24 OR Equivalent  
Red Wire:Positive (+)  
Black Wire:Negative (-)  
Yellow wire:FG or RD Signal

MODEL NO	RATED VOLTAGE V	OPERATING VOLTAGE V	RATED CURRENT A	ACTUAL CURRENT A	RATED POWER	RATED SPEED RPM (±10%)	MAX. AIR FLOW		MAX.STATIC AIR PRESSURE		NOISE LEVEL db(A)
							CMM	CFM	InH2O	mmH2O	
YDH12025H12B	12	6~13.2	1.2	1.0	14.4	2500	2.632	92.94	0.514	13.06	47.8
YDH12025M12B	12	6~13.2	0.7	0.65	8.4	2200	2.316	81.78	0.398	10.11	45.0
YDH12025L12B	12	6~13.2	0.4	0.35	4.8	1900	2.000	70.63	0.297	7.54	41.8
YDH12025H24B	24	12~26.4	0.7	0.6	16.8	2500	2.632	92.94	0.514	13.06	47.8
YDH12025M24B	24	12~26.4	0.4	0.35	9.6	2200	2.316	81.78	0.398	10.11	45.0
YDH12025L24B	24	12~26.4	0.25	0.2	6	1900	2.000	70.63	0.297	7.54	41.8

# 九 龙 电 机

AC Axial Fan  
AC轴流风机

AC All-Metal Axial Fan  
AC全金属轴流风扇

DC Axial Fan  
DC轴流风机

DC Centrifugal Fan  
DC离心风机

EC Axial Fan  
EC轴流风机

EC Centrifugal Fan  
EC离心风机

AC Centrifugal Fan  
AC离心风机

Fan Accessories  
风机配件

# CONTENTS

## 目录



163/173

**直流单进口离心风机 ( 24V/48V )**

DC centrifugal fan single inlet(24V/48V)

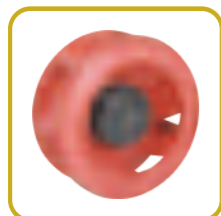

174/187

**直流后向式离心风机 ( 24V/48V )**

DC centrifugal fan backward curved (24V/48V)

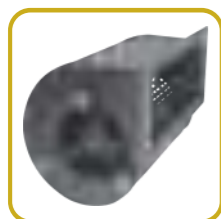

188/197

**直流双进口离心风机 ( 24V/48V )**

DC centrifugal blower dual inlet (24V/48V)

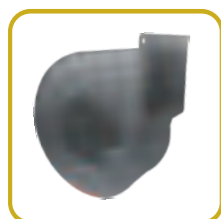

198/210

**直流单进口离心风机 ( 310V )**

DC centrifugal fan single inlet (310V)



211/229

**直流后向式离心风机 ( 310V )**

DC centrifugal fan backward curved (310V)



230/238

**直流双进口离心风机 ( 310V )**

DC centrifugal blower dual inlet (310V)



239/248

**EC轴流风机**

EC Axial Fan



249/261

**EC单进口离心风机**

EC centrifugal fan single inlet

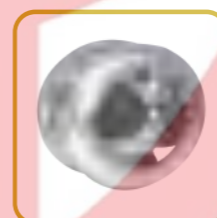

262/279

**EC后向式离心风机**

EC centrifugal fan backward curved



280/288

**EC双进口离心风机**

EC centrifugal blower dual inlet

# 九龙电机

本样册仅做选型参考,具体以规格书为准。  
This sample book is for reference only. Please refer to the specification for details.  
如需特殊电压也可根据洽询提供, 本公司保留技术改动权利。  
Special voltage may be provided if necessary according to the inquiry. Julong all technical modification rights reserved.

## 风机产品型号命名规则

- DC/EC电机/风机产品型号编码具体意义如下:

**Y** **E** **H** **133** **A** **C** **A2** - **A01** - **W**  
**1** **2** **3** **4** **5** **6** **7** **8** **9**

- 各位代码的含义:

- 一、公司名称: Y: 伊赛电机
- 二、电机类别: E: EC电机 D: DC电机
- 三、产品类别: D: 单进口前向离心风机 M: 马达 S: 双进口前向离心风机  
 H: 后风向式离心机 G: 贯流风机 Z: 轴流风机  
 P: 盘管式室内机 Q: 其它类风机
- 四、风轮/电机直径: 072:  $\varnothing 72\text{mm}$ ; 092:  $\varnothing 92\text{mm}$ ; .....
- 五、设计编号&叶轮高度/马达高度: A-Z
- 六、电机规格: E:053 F:060 G:072 H:092 I:102 J:138.....
- 七、电压: 12: DC12V; 24: DC24V; 36: DC36V; 48: DC48V; D3: DC310等.....  
 A1: AC110V; A2: AC220V; A3: AC380V;
- 八、流水码(客户线材&端子): 流水号表示A01; A02; A03.....
- 九、附件: W; 蜗壳, D; 导风圈.....

DC风机接线图(DC24V/48V)

Conn.	Designation	Colour	Function / assignment
1	V+	Red	DC24V/48V,最大电压波动 $\pm 5\%$
2	GND	Blue	GND
5	PWM	Yellow	PWM OR Voltage input
6	FG	White	Tach output:3pulse per revolution

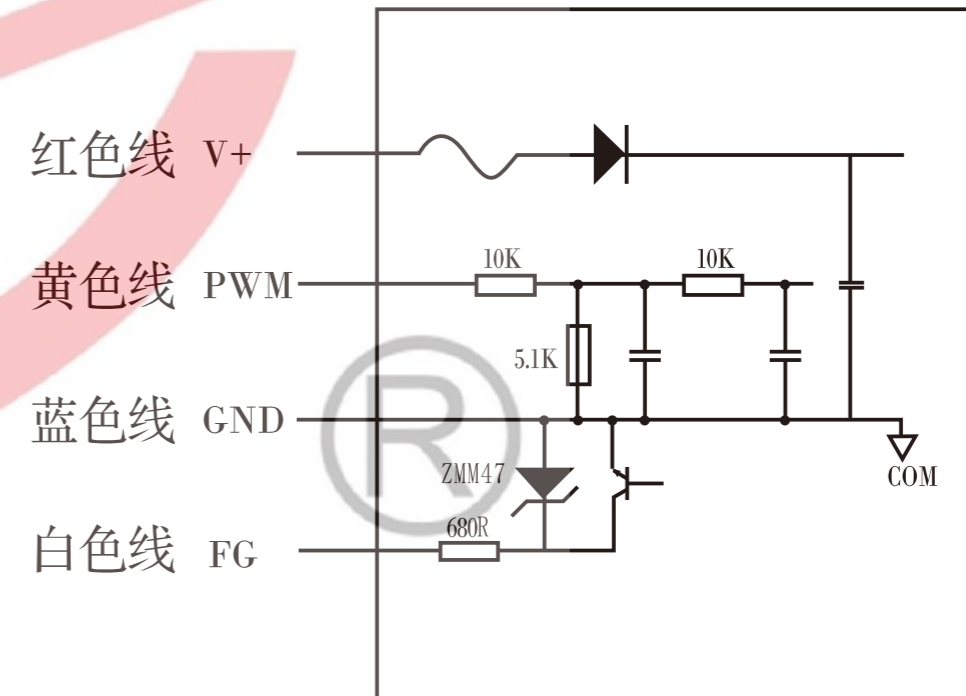

# 九 龙 电 机

## DC风机接线图(DC310V)

Conn.	Designation	Colour	Function / assignment
1	HV+	Red	DC310V+
2	GND	Black	GND
3	GND	Green	GND
4	VCC	White	DC10V Output, 30mA MAX
5	PWM	Yellow	PWM OR Voltage input
6	FG	Blue	Tach output:3pulse per revolution

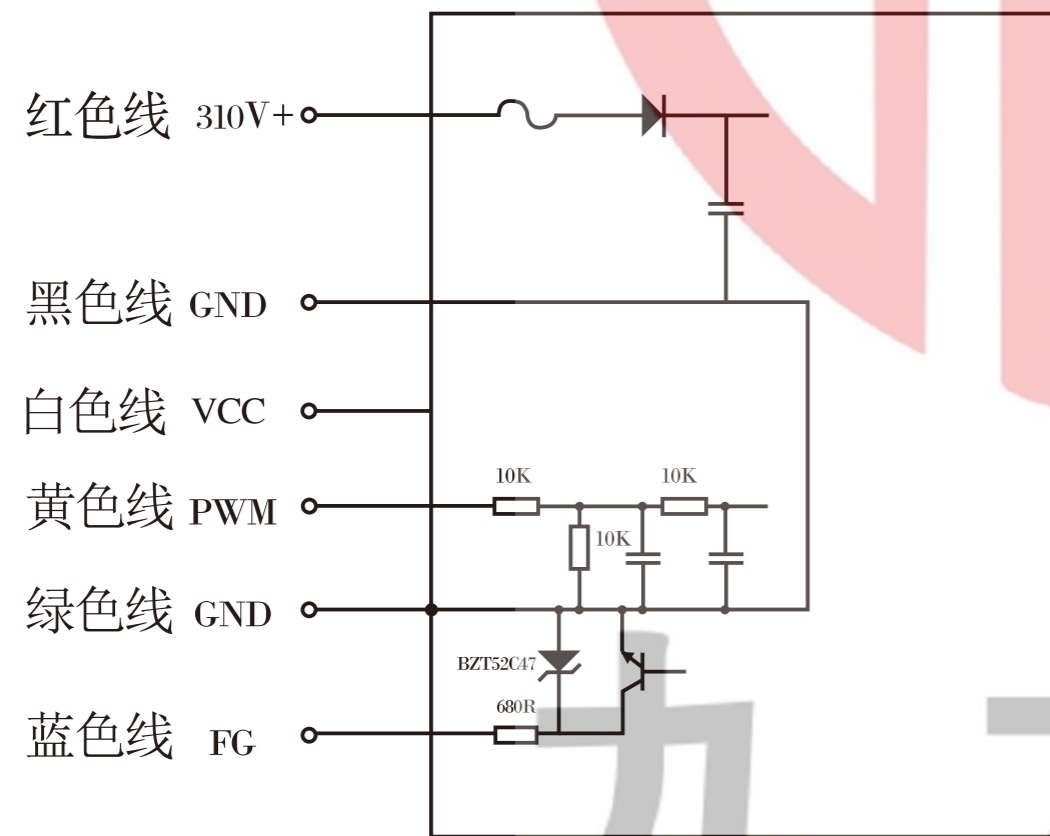

## EC风机接线图

Conn.	Designation	Colour	Function / assignment
1	E	Green/yellow	Protective earth
2	L	Brown	Power supply 230 VAC, 50/ 60 Hz
3	N	Blue	Neutral conductor
4	PWM	Yellow	PWM OR Voltage input
5	GND	Blue	GND
6	VCC	Red	DC 10V Output,30mA MAX
7	Tach	white	Tach output: 3pulse per revolution

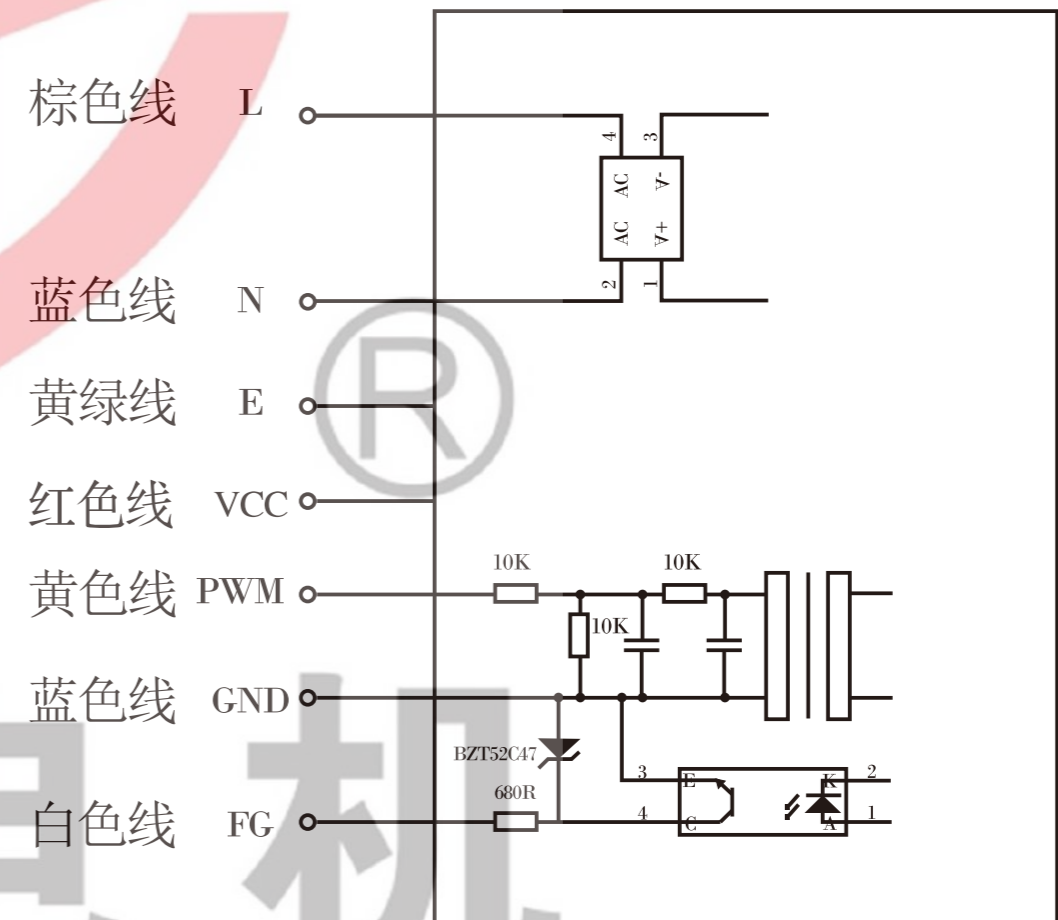

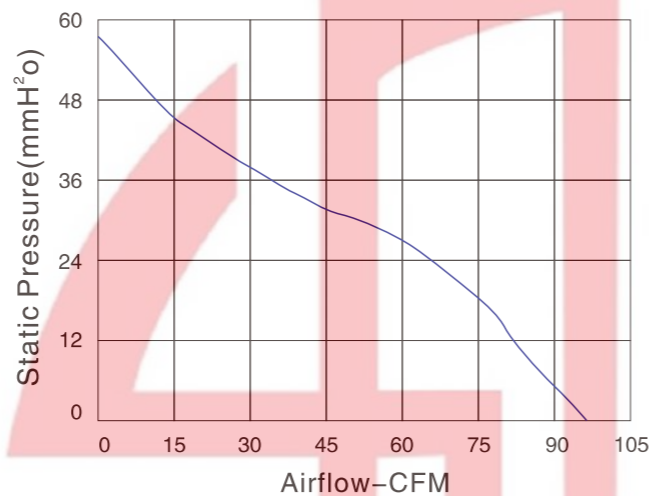

尺寸 Size: Ø97mm × 50mm  
 风量 Airflow: 93.6CFM  
 噪音 Noise: 55dB(A)  
 风叶 Impeller Material: Metal  
 工作方式 Operation mode: S1  
 温度范围 Operating Temperature: -10°C~+65°C  
 防护等级 Type of protection: IP44  
 绝缘等级 Insulation class: "B"

产品型号 Model	电压 Voltage VDC	电流 Current A	功率 Power W	转速 Speed RPM	风量 Air Flow CFM	静压 Static Pressure mmH <sub>2</sub> O	噪音 Noise dB(A)
YDD097AE24-A01-W	24	1.4	34	2500	93.6	57.1	55
YDD097AE48-A01-W	48	0.7	34	2500	93.6	57.1	55

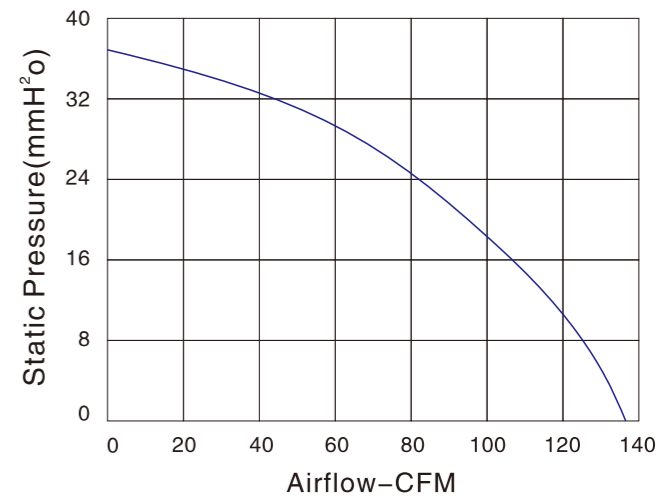
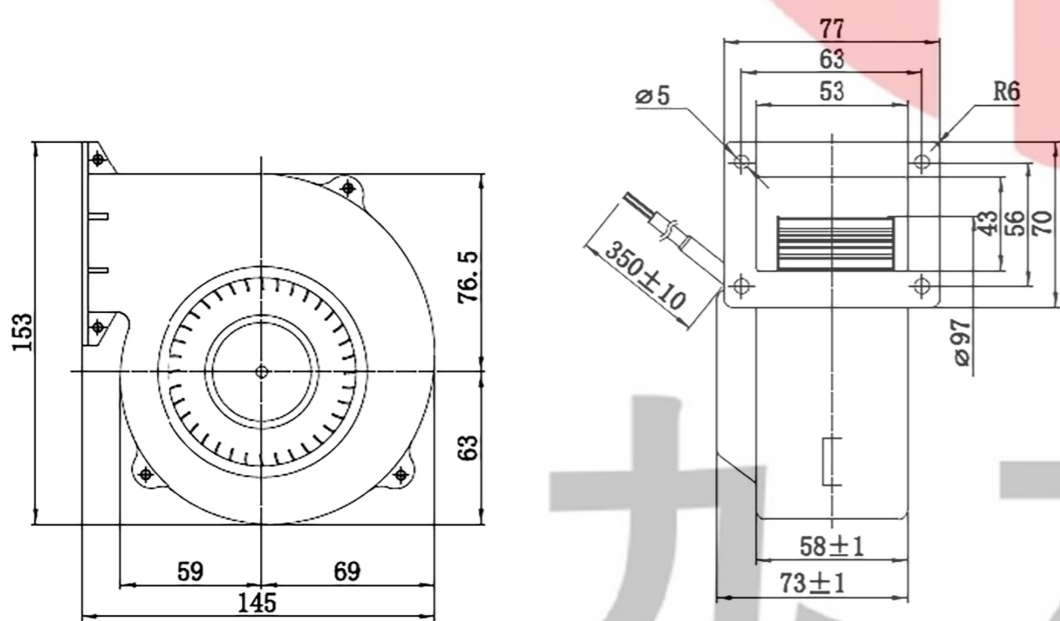

尺寸 Size: Ø108mm × 62mm  
 风量 Airflow: 136.2CFM  
 噪音 Noise: 63.2dB(A)  
 风叶 Impeller Material: Metal  
 工作方式 Operation mode: S1  
 温度范围 Operating Temperature: -10°C~+65°C  
 防护等级 Type of protection: IP44  
 绝缘等级 Insulation class: "B"

产品型号 Model	电压 Voltage VDC	电流 Current A	功率 Power W	转速 Speed RPM	风量 Air Flow CFM	静压 Static Pressure mmH <sub>2</sub> O	噪音 Noise dB(A)
YDD108AG24-B01-W	24	2.4	57	2800	136.2	37.9	63.2
YDD108AG48-A01-W	48	1.2	57	2800	136.2	37.9	63.2

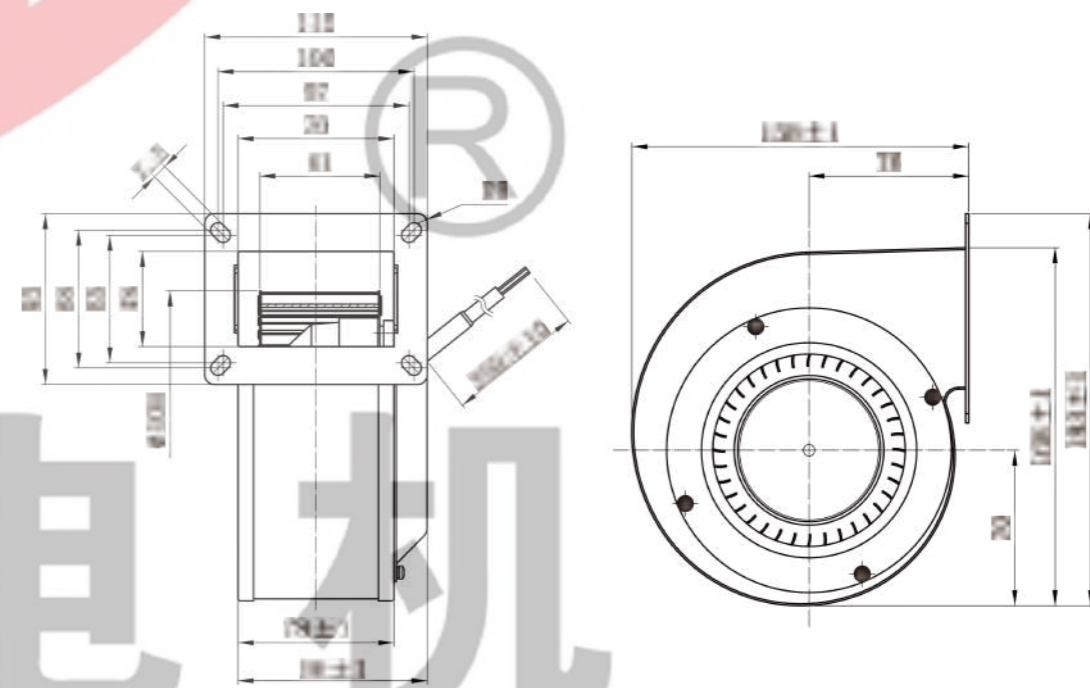

九 龙 电 机



JULONG MOTOR  
AC/DC FANS COOLING FANS



本样机仅做选型参考，具体以规格书为准。  
This sample book is for reference only. Please refer to the specification for details.  
如需特殊电压也可根据需求提供。本公司保留技术知识产权。  
Special voltage may be provided flexibly according to the requirement. All technical modification rights reserved.

Http://www.xtgygs.cn

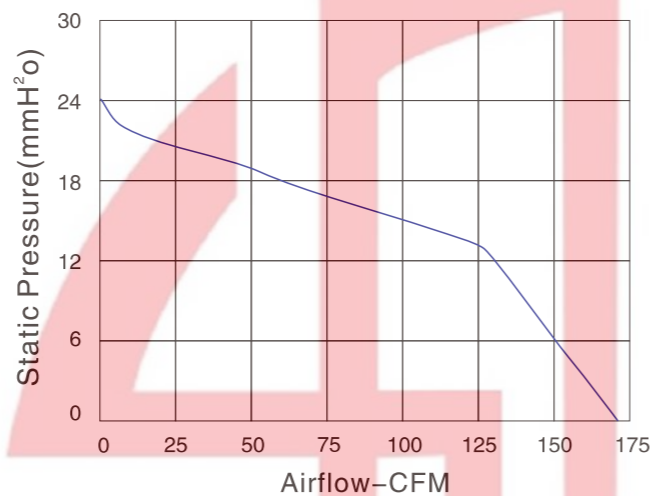

尺寸 Size: Ø120mmX62mm  
风量 Airflow: 172CFM  
噪音 Noise: 57.8dB(A)  
风叶 Impeller Material: Metal  
工作方式 Operation mode: S1  
温度范围 Operating Temperature: -10°C~+65°C  
防护等级 Type of protection: IP44  
绝缘等级 Insulation class: "B"

产品型号 Model	电压 Voltage VDC	电流 Current A	功率 Power W	转速 Speed RPM	风量 Air Flow CFM	静压 Static Pressure mmH <sub>2</sub> O	噪音 Noise dB(A)
YDD120BG24-B01-W	24	2.3	54	2400	172	24.5	57.8
YDD120BG48-A01-W	48	1.1	54	2400	172	24.5	57.8

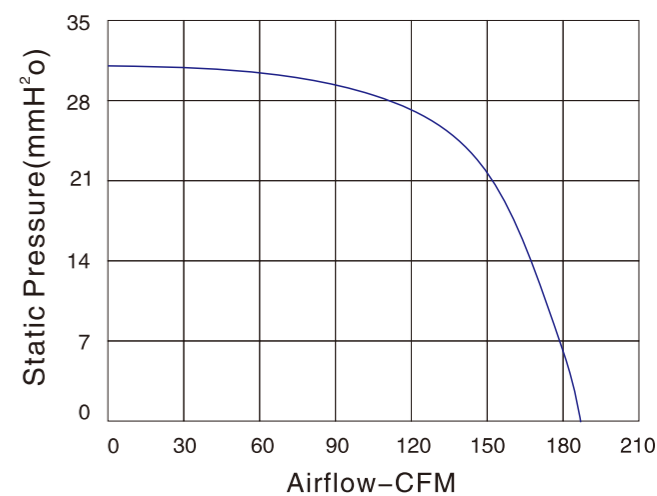
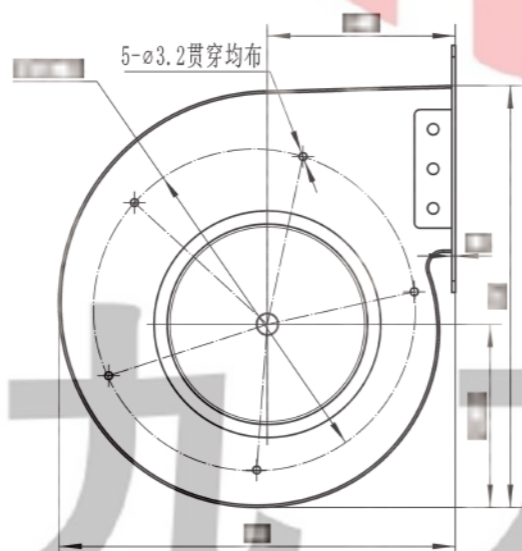
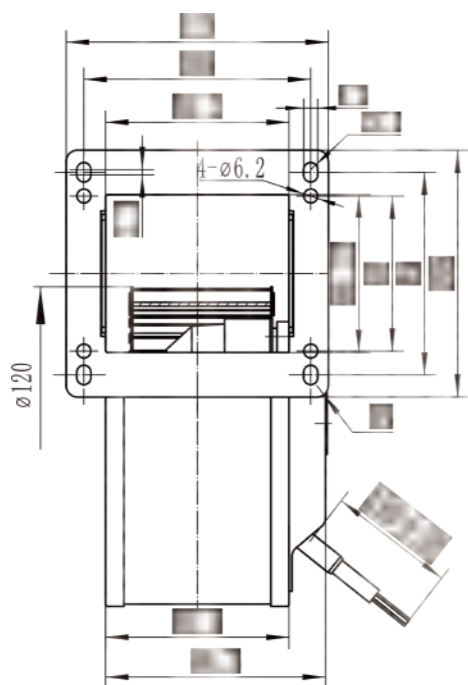

尺寸 Size: Ø133mmX50mm  
风量 Airflow: 183.6CFM  
噪音 Noise: 60dB(A)  
风叶 Impeller Material: Metal  
工作方式 Operation mode: S1  
温度范围 Operating Temperature: -10°C~+65°C  
防护等级 Type of protection: IP44  
绝缘等级 Insulation class: "B"

产品型号 Model	电压 Voltage VDC	电流 Current A	功率 Power W	转速 Speed RPM	风量 Air Flow CFM	静压 Static Pressure mmH <sub>2</sub> O	噪音 Noise dB(A)
YDD133AG24-B01-W	24	3.6	87	2400	183.6	31.2	60
YDD133AG48-A01-W	48	1.8	87	2400	183.6	31.2	60

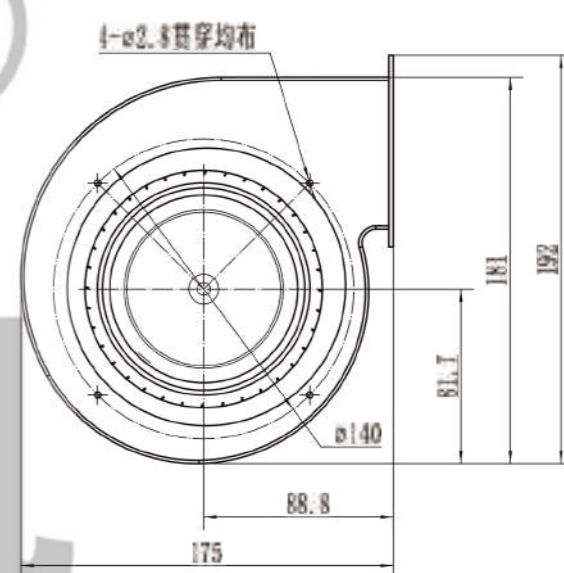
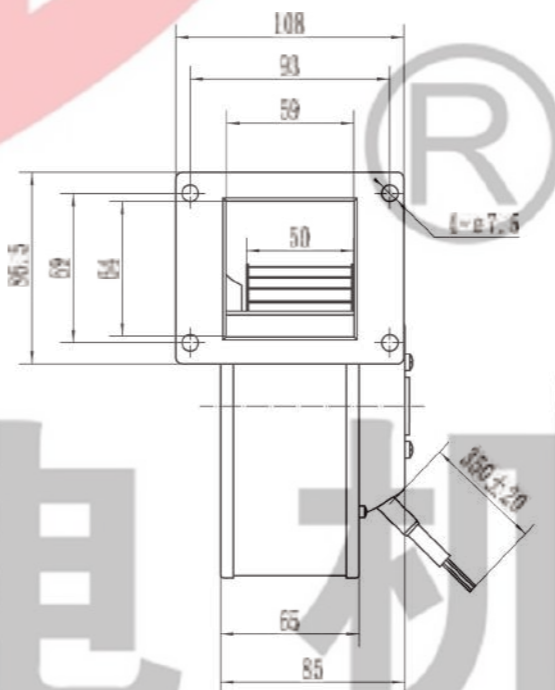

九 龙 电 机

AC Axial Fan  
AC轴流风机

AC All-Metal Axial Fan  
AC全金属轴流风扇

DC Axial Fan  
DC轴流风机

DC Centrifugal Fan  
DC离心风机

EC Axial Fan  
EC轴流风机

EC Centrifugal Fan  
EC离心风机

AC Centrifugal Fan  
AC离心风机

Fan Accessories  
风机配件

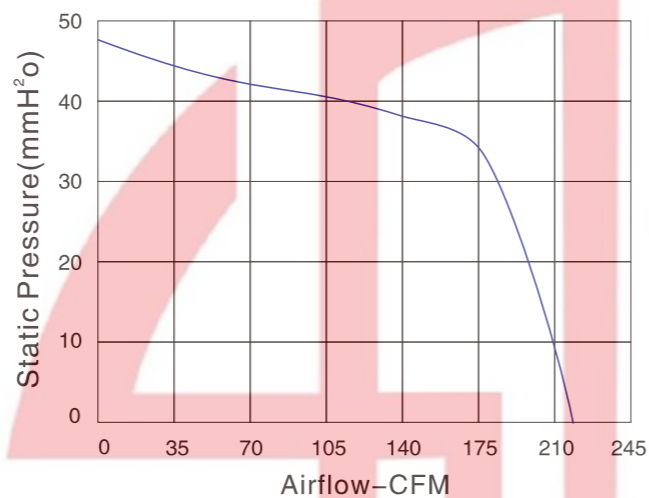

尺寸 Size: Ø133mmX74mm  
风量 Airflow: 224CFM  
噪音 Noise: 58.2dB(A)  
风叶 Impeller Material: Metal  
工作方式 Operation mode: S1  
温度范围 Operating Temperature: -10°C~+65°C  
防护等级 Type of protection: IP44  
绝缘等级 Insulation class: "B"

产品型号 Model	电压 Voltage VDC	电流 Current A	功率 Power W	转速 Speed RPM	风量 Air Flow CFM	静压 Static Pressure mmH <sub>2</sub> O	噪音 Noise dB(A)
YDD133BG24-B01-W	24	3.4	82	2200	224	48	58.2
YDD133BG48-A01-W	48	1.7	82	2200	224	48	58.2

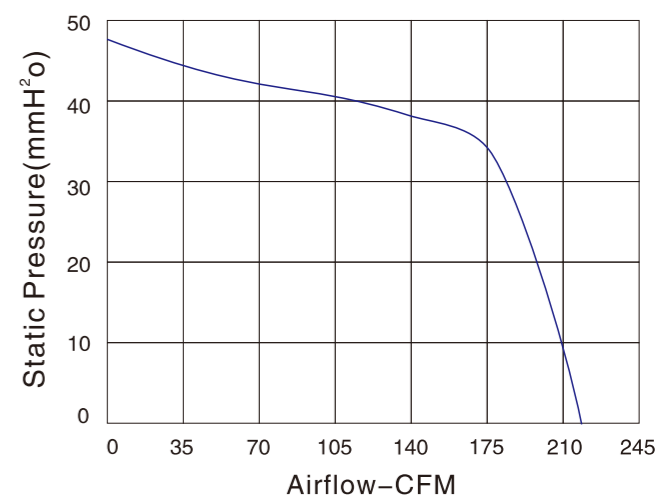
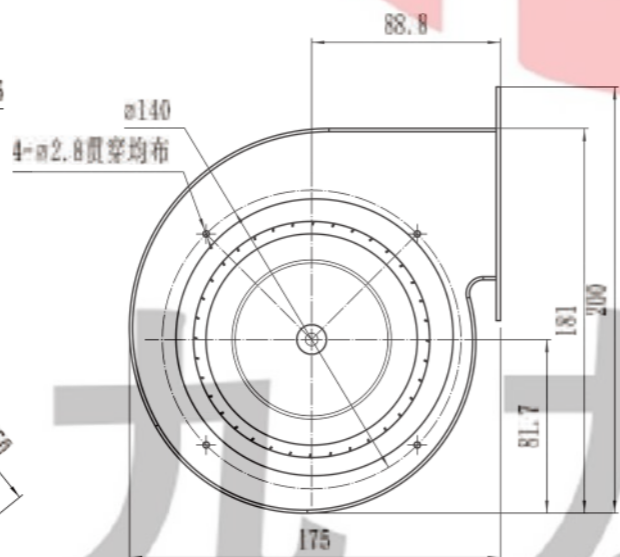
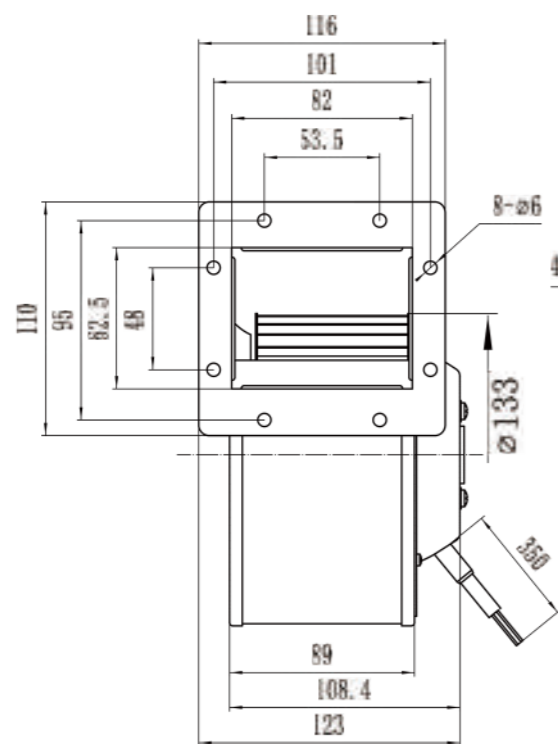

尺寸 Size: Ø133mmX74mm  
风量 Airflow: 224CFM  
噪音 Noise: 58.2dB(A)  
风叶 Impeller Material: Metal  
工作方式 Operation mode: S1  
温度范围 Operating Temperature: -10°C~+65°C  
防护等级 Type of protection: IP44  
绝缘等级 Insulation class: "B"

产品型号 Model	电压 Voltage VDC	电流 Current A	功率 Power W	转速 Speed RPM	风量 Air Flow CFM	静压 Static Pressure mmH <sub>2</sub> O	噪音 Noise dB(A)
YDD133CG24-B01-W	24	3.4	82	2200	224	48	58.2
YDD133CG48-A01-W	48	1.7	82	2200	224	48	58.2

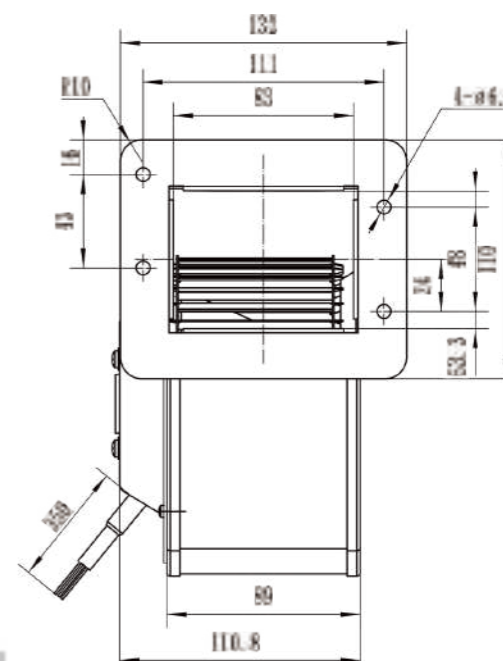
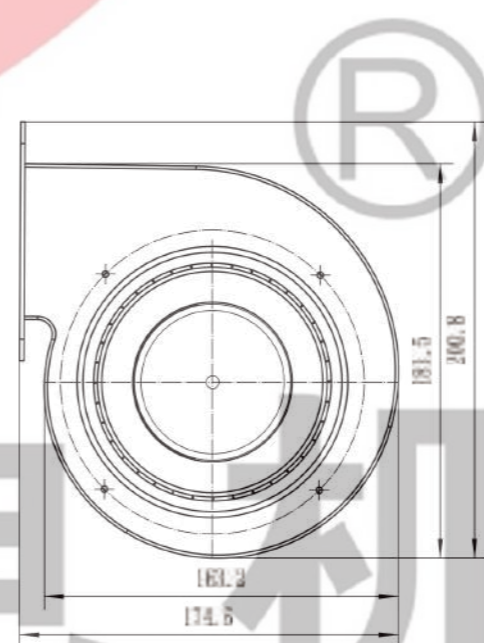

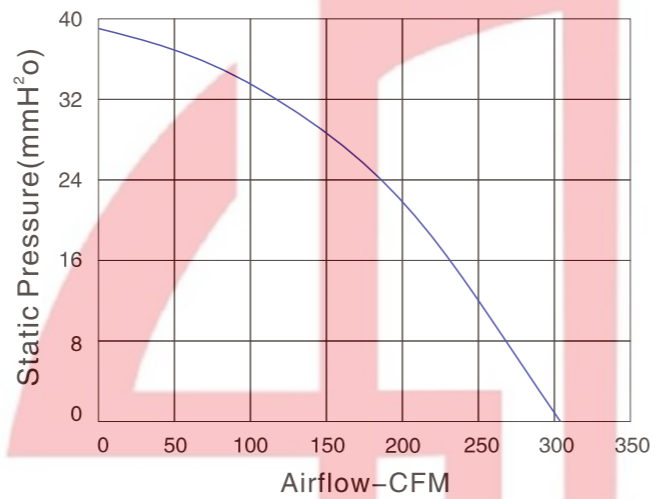

尺寸 Size: Ø140mmX62mm  
风量 Airflow: 306CFM  
噪音 Noise: 64dB(A)  
风叶 Impeller Material: PA66  
工作方式 Operation mode: S1  
温度范围 Operating Temperature: -10°C~+65°C  
防护等级 Type of protection: IP44  
绝缘等级 Insulation class: "B"

产品型号 Model	电压 Voltage VDC	电流 Current A	功率 Power W	转速 Speed RPM	风量 Air Flow CFM	静压 Static Pressure mmH <sub>2</sub> O	噪音 Noise dB(A)
YDD140BG24-B01-W	24	4.2	102	2000	306	39.3	64
YDD140BG48-A01-W	48	2.1	102	2000	306	39.3	64

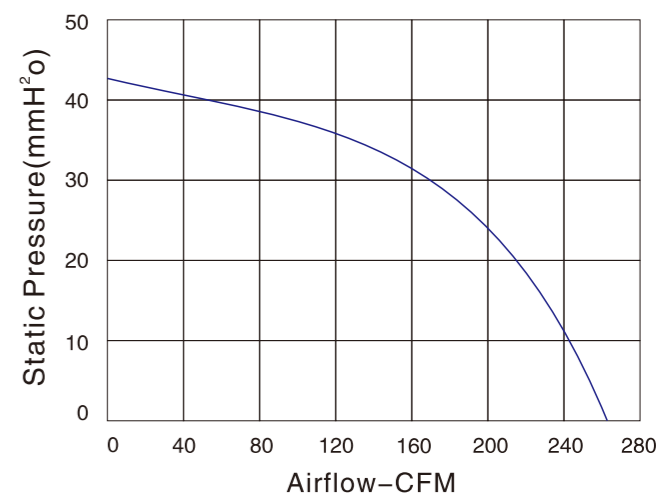
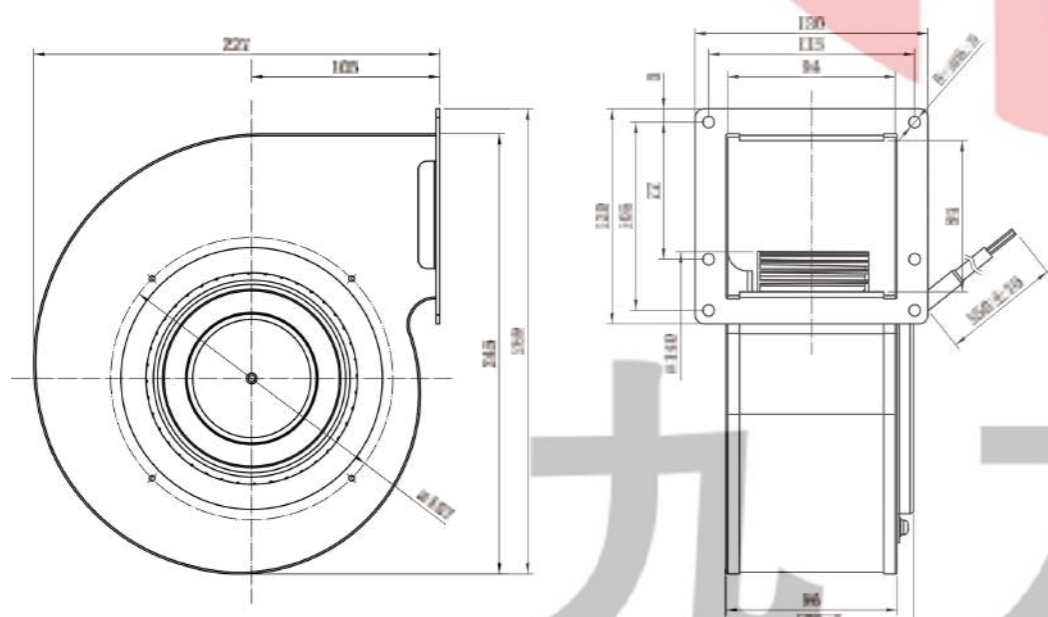

尺寸 Size: Ø150mmX72mm  
风量 Airflow: 262.5CFM  
噪音 Noise: 67.1dB(A)  
风叶 Impeller Material: Metal  
工作方式 Operation mode: S1  
温度范围 Operating Temperature: -10°C~+65°C  
防护等级 Type of protection: IP44  
绝缘等级 Insulation class: "B"

产品型号 Model	电压 Voltage VDC	电流 Current A	功率 Power W	转速 Speed RPM	风量 Air Flow CFM	静压 Static Pressure mmH <sub>2</sub> O	噪音 Noise dB(A)
YDD150AG24-B01-W	24	4.2	100	2100	262.5	43	67.1
YDD150AG48-A01-W	48	2.1	100	2100	262.5	43	67.1

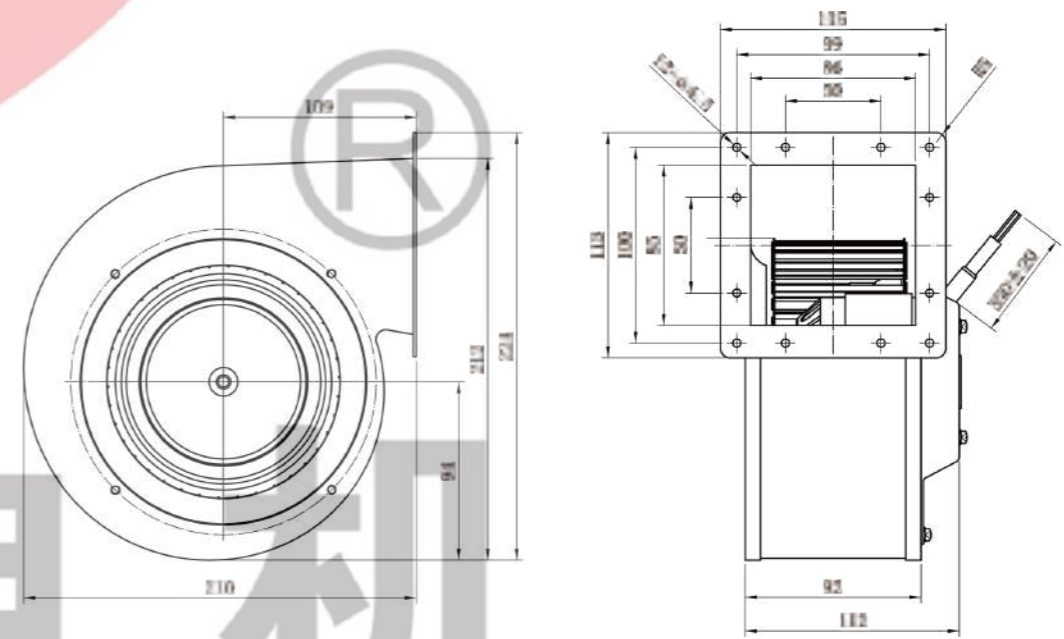

九 龙 电 机

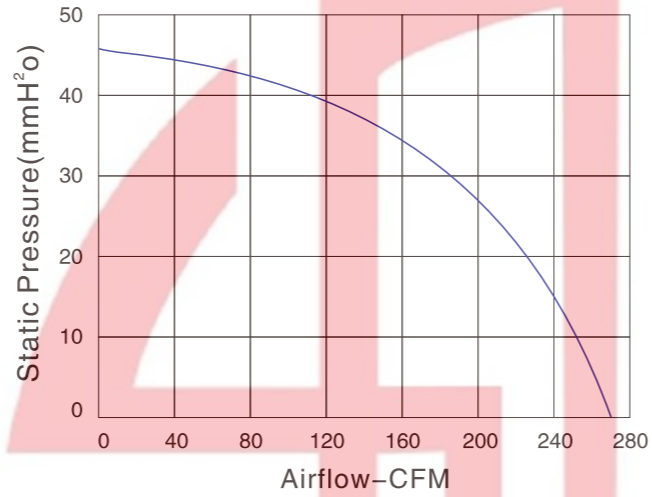

尺寸 Size: Ø150mmX72mm  
风量 Airflow: 262.5CFM  
噪音 Noise: 67.1dB(A)  
风叶 Impeller Material: Metal  
工作方式 Operation mode: S1  
温度范围 Operating Temperature: -10°C~+65°C  
防护等级 Type of protection: IP44  
绝缘等级 Insulation class: "B"

产品型号 Model	电压 Voltage VDC	电流 Current A	功率 Power W	转速 Speed RPM	风量 Air Flow CFM	静压 Static Pressure mmH <sub>2</sub> O	噪音 Noise dB(A)
YDD150BG24-B01-W	24	4.2	100	2100	262.5	43	67.1
YDD150BG48-A01-W	48	2.1	100	2100	262.5	43	67.1

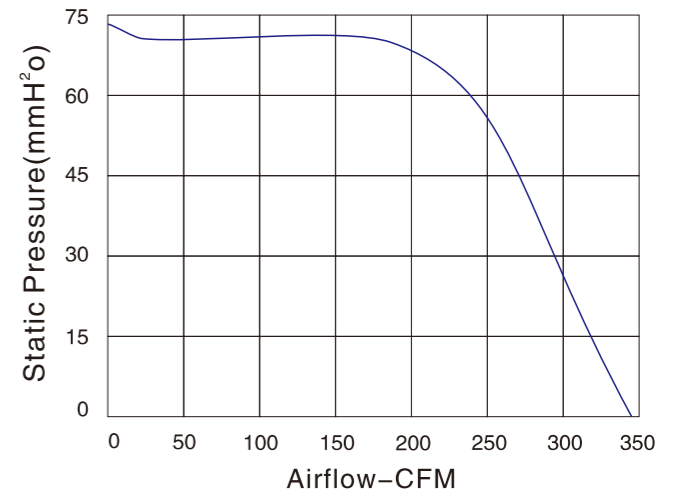
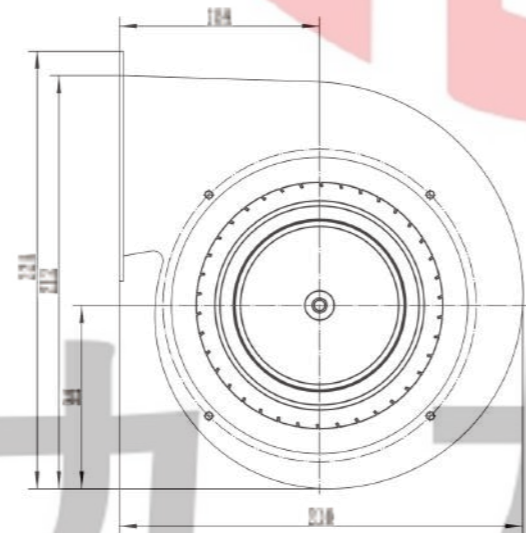
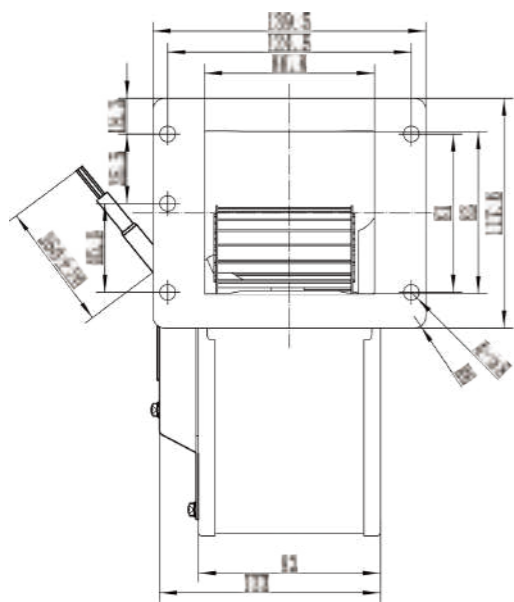

尺寸 Size: Ø160mmX72mm  
风量 Airflow: 348.7CFM  
噪音 Noise: 63.5dB(A)  
风叶 Impeller Material: Metal  
工作方式 Operation mode: S1  
温度范围 Operating Temperature: -10°C~+65°C  
防护等级 Type of protection: IP44  
绝缘等级 Insulation class: "B"

产品型号 Model	电压 Voltage VDC	电流 Current A	功率 Power W	转速 Speed RPM	风量 Air Flow CFM	静压 Static Pressure mmH <sub>2</sub> O	噪音 Noise dB(A)
YDD160AG24-B01-W	24	5	120	1950	348.7	59.5	63.5
YDD160AG48-A01-W	48	2.5	120	1950	348.7	59.5	63.5

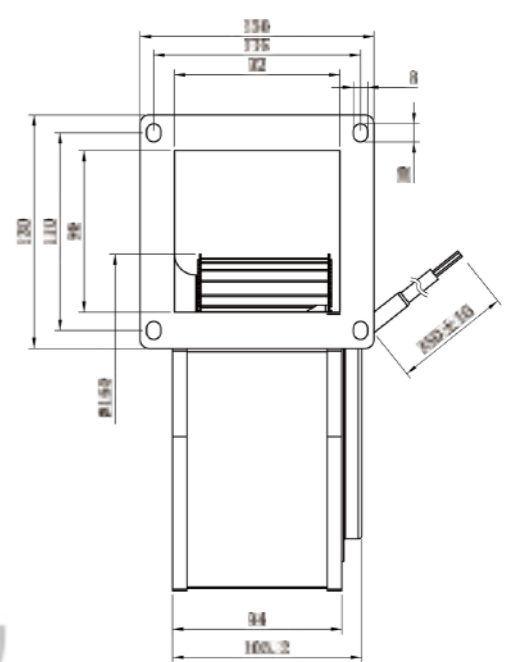
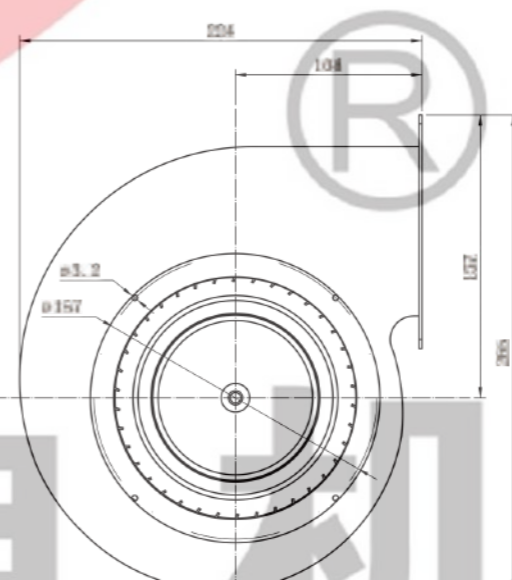

九龙电机



JIULONG MOTOR  
AC/DC FANS COOLING FANS



UL  
E248719



本样图仅供参考，具体以规格书为准。  
This sample book is for reference only. Please refer to the specification for details.  
如需特殊电压也可根据需求提供。本公司保留技术知识产权。  
Special voltage may be provided flexibly according to the requirement. All technical modification rights reserved.

Http://www.xtgygs.cn



尺寸 Size:  $\varnothing 180\text{mm} \times 90\text{mm}$   
风量 Airflow: 527.9CFM  
噪音 Noise: 63.4dB(A)  
风叶 Impeller Material: Metal  
工作方式 Operation mode: S1  
温度范围 Operating Temperature:  $-10^{\circ}\text{C} \sim +65^{\circ}\text{C}$   
防护等级 Type of protection: IP44  
绝缘等级 Insulation class: "B"

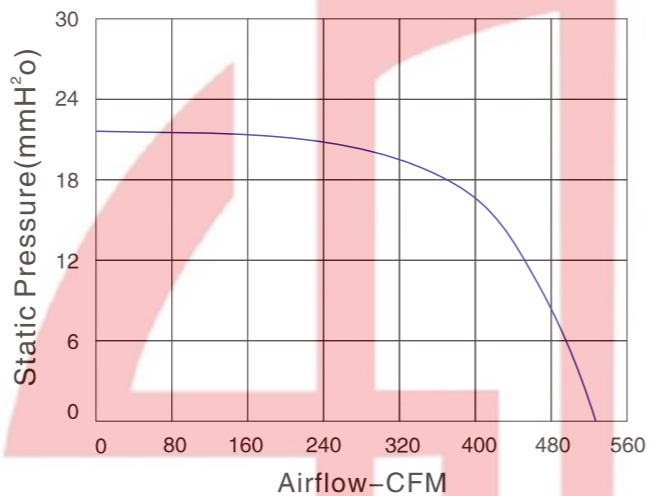

尺寸 Size:  $\varnothing 133\text{mm} \times 62\text{mm}$   
风量 Airflow: 202CFM  
噪音 Noise: 63dB(A)  
风叶 Impeller Material: PA66  
工作方式 Operation mode: S1  
温度范围 Operating Temperature:  $-10^{\circ}\text{C} \sim +65^{\circ}\text{C}$   
防护等级 Type of protection: IP44  
绝缘等级 Insulation class: "B"

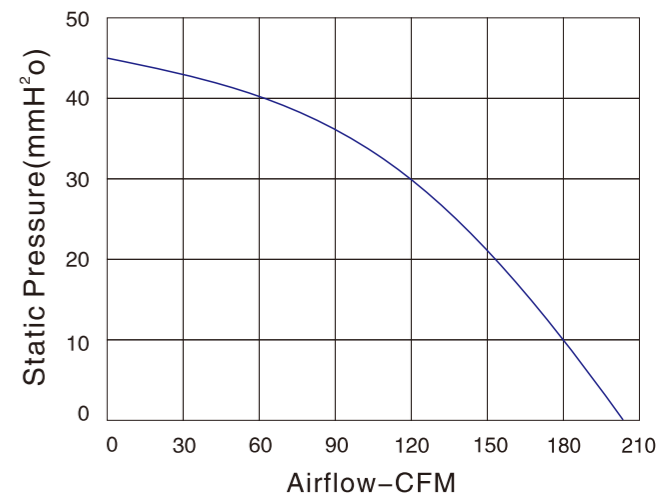

产品型号 Model	电压 Voltage VDC	电流 Current A	功率 Power W	转速 Speed RPM	风量 Air Flow CFM	静压 Static Pressure mmH <sub>2</sub> O	噪音 Noise dB(A)
YDD180AH24-A01-W	24	4.6	110	1350	527.9	22.1	63.4
YDD180AH48-A01-W	48	2.3	110	1350	527.9	22.1	63.4

产品型号 Model	电压 Voltage VDC	电流 Current A	功率 Power W	转速 Speed RPM	风量 Air Flow CFM	静压 Static Pressure mmH <sub>2</sub> O	噪音 Noise dB(A)
YDH133AG24-B01	24	2	48	4500	202	45	63
YDH133AG48-A01	48	1	48	4500	202	45	63

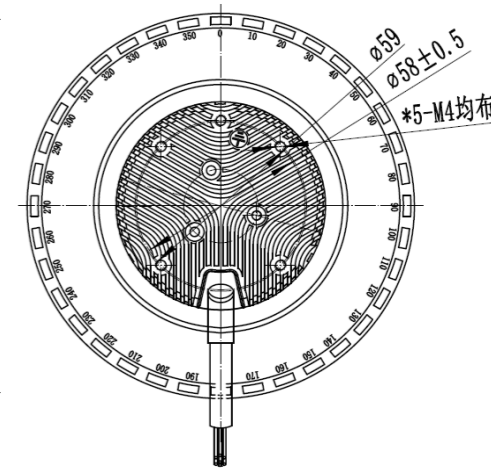
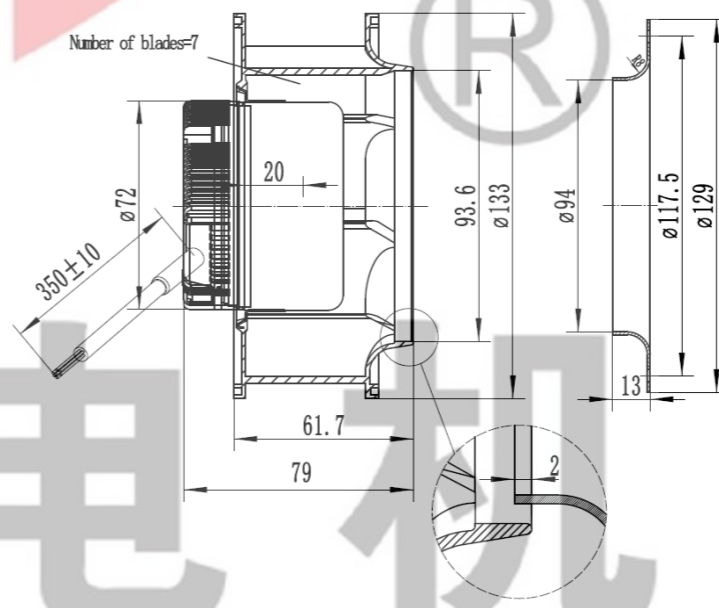
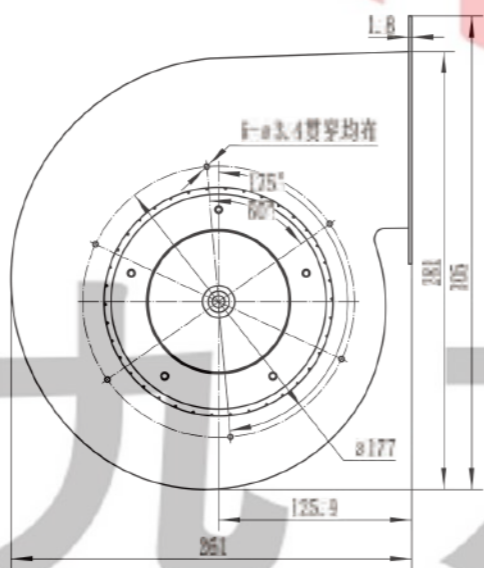
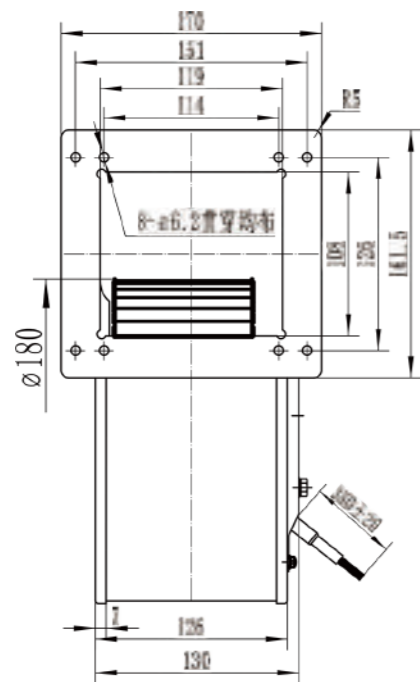

AC Axial Fan  
AC轴流风机

AC All-Metal Axial Fan  
AC全金属轴流风扇

DC Axial Fan  
DC轴流风机

DC Centrifugal Fan  
DC离心风机

EC Axial Fan  
EC轴流风机

EC Centrifugal Fan  
EC离心风机

AC Centrifugal Fan  
AC离心风机

Fan Accessories  
风机配件



JULONG MOTOR  
AC/DC FANS COOLING FANS



本样图仅供参考，具体以实物为准。  
This sample book is for reference only. Please refer to the specification for details.  
如需特殊电压也可根据需求提供。本公司保留技术知识产权。  
Special voltage may be provided flexibly according to the query. All technical modification rights reserved.

Http://www.xtgygs.cn

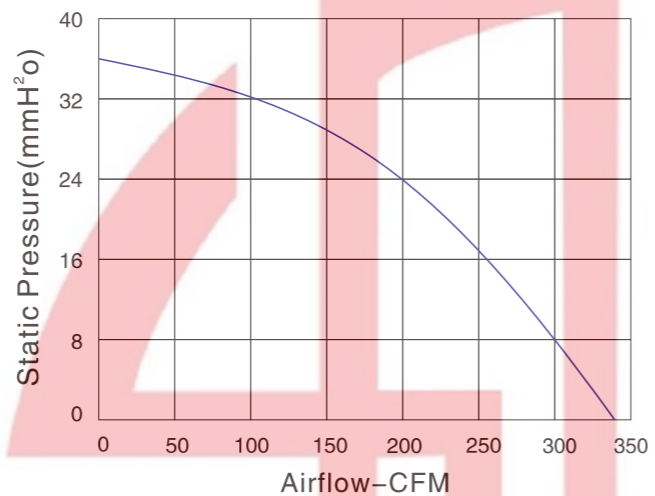

尺寸 Size: Ø175mmX65mm  
风量 Airflow: 335CFM  
噪音 Noise: 68dB(A)  
风叶 Impeller Material: PA66  
工作方式 Operation mode: S1  
温度范围 Operating Temperature: -10°C~+65°C  
防护等级 Type of protection: IP44  
绝缘等级 Insulation class: "B"

产品型号 Model	电压 Voltage VDC	电流 Current A	功率 Power W	转速 Speed RPM	风量 Air Flow CFM	静压 Static Pressure mmH <sub>2</sub> O	噪音 Noise dB(A)
YDH175AG24-B01	24	1.8	43	3100	335	35.7	68
YDH175AG48-A01	48	0.9	43	3100	335	35.7	68

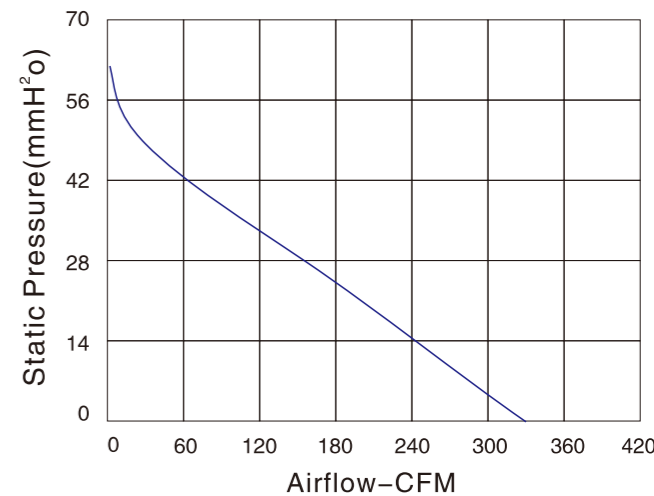
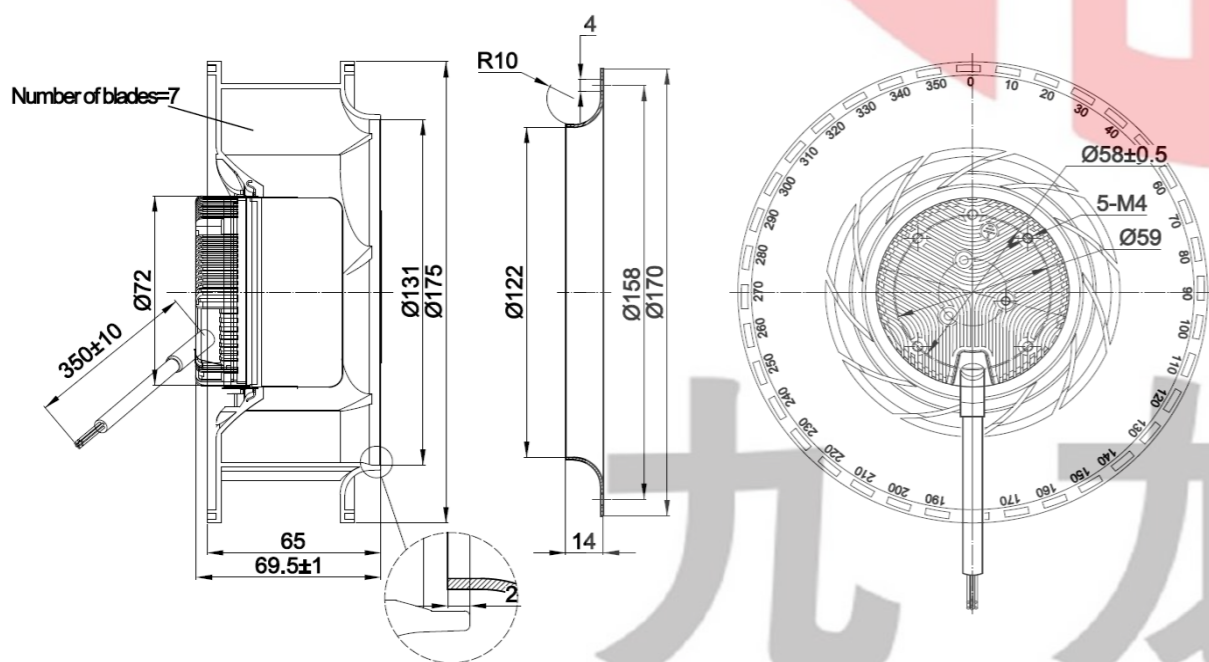

尺寸 Size: Ø180mmX69mm  
风量 Airflow: 340CFM  
噪音 Noise: 61dB(A)  
风叶 Impeller Material: ABS+GF  
工作方式 Operation mode: S1  
温度范围 Operating Temperature: -10°C~+65°C  
防护等级 Type of protection: IP44  
绝缘等级 Insulation class: "B"

产品型号 Model	电压 Voltage VDC	电流 Current A	功率 Power W	转速 Speed RPM	风量 Air Flow CFM	静压 Static Pressure mmH <sub>2</sub> O	噪音 Noise dB(A)
YDH180AG24-B01	24	2.4	58	2800	340	62.7	61
YDH180AG48-A01	48	1.2	58	2800	340	62.7	61

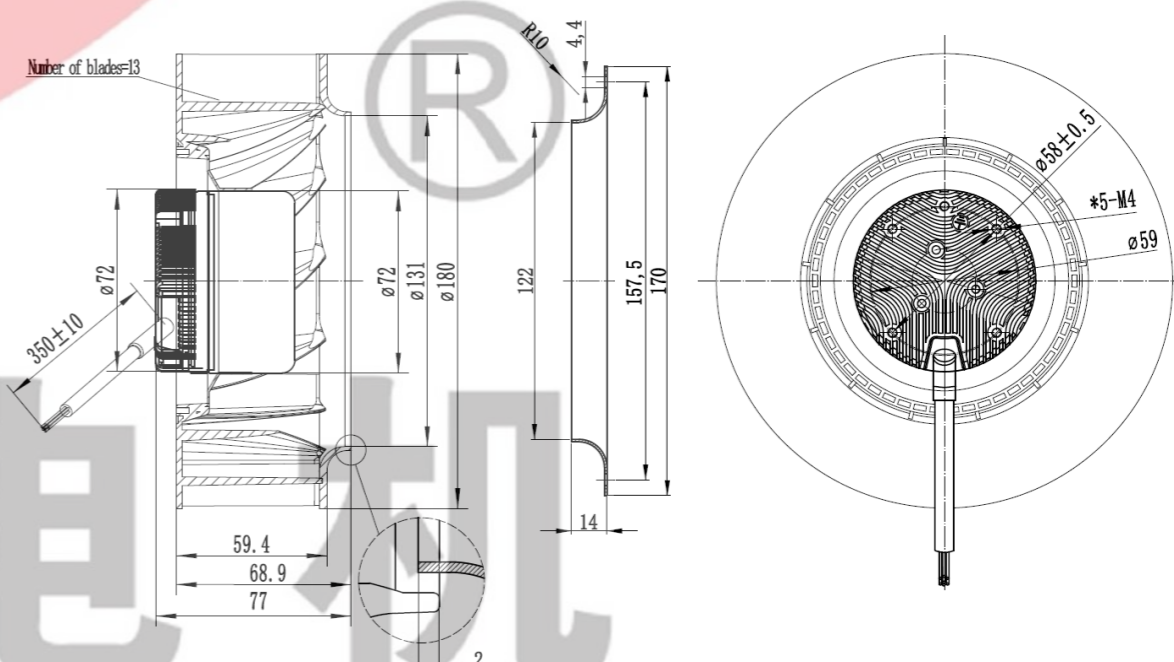

AC Axial Fan  
AC轴流风机

AC All-Metal Axial Fan  
AC全金属轴流风扇

DC Axial Fan  
DC轴流风机

DC Centrifugal Fan  
DC离心风机

EC Axial Fan  
EC轴流风机

EC Centrifugal Fan  
EC离心风机

AC Centrifugal Fan  
AC离心风机

Fan Accessories  
风机配件



JULONG MOTOR  
AC/DC FANS COOLING FANS



本样图仅供参考，具体以实物为准。  
This sample book is for reference only. Please refer to the specification for details.  
如需特殊电压也可根据需求提供。本公司保留技术知识产权。  
Special voltage may be provided flexibly according to the requirement. All technical modification rights reserved.

Http://www.xtgygs.cn

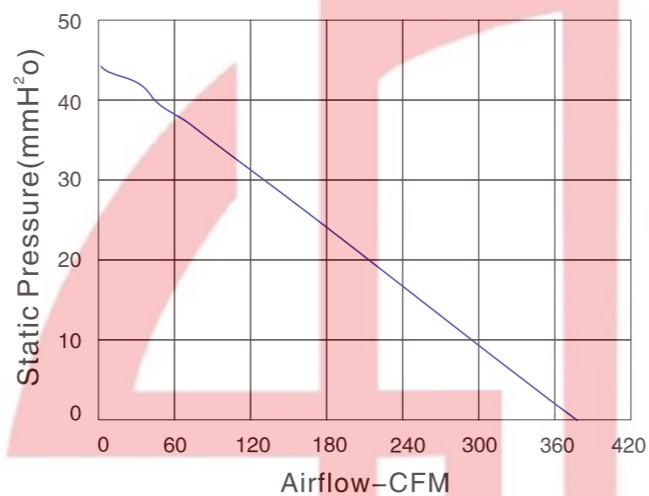

尺寸 Size: Ø190mmX61mm  
风量 Airflow: 336CFM  
噪音 Noise: 64dB(A)  
风叶 Impeller Material: PA66  
工作方式 Operation mode: S1  
温度范围 Operating Temperature: -10°C~+65°C  
防护等级 Type of protection: IP44  
绝缘等级 Insulation class: "B"

产品型号 Model	电压 Voltage VDC	电流 Current A	功率 Power W	转速 Speed RPM	风量 Air Flow CFM	静压 Static Pressure mmH <sub>2</sub> O	噪音 Noise dB(A)
YDH190BG24-B01	24	2.6	62	3000	366	44	64
YDH190BG48-A01	48	1.3	62	3000	366	44	64

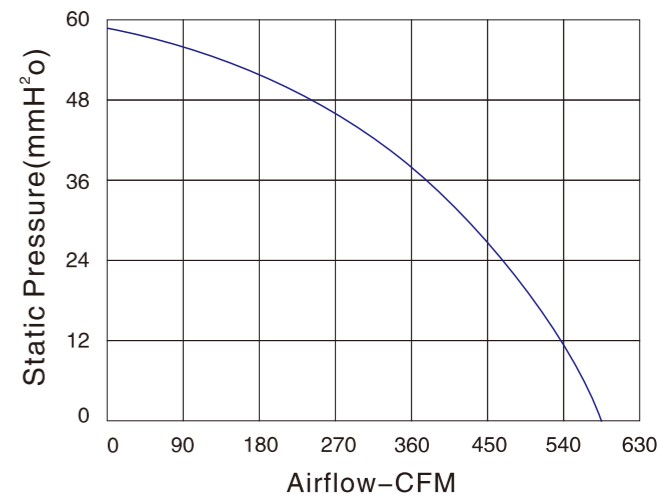

尺寸 Size: Ø220mmX65mm  
风量 Airflow: 583CFM  
噪音 Noise: 75dB(A)  
风叶 Impeller Material: PA66  
工作方式 Operation mode: S1  
温度范围 Operating Temperature: -10°C~+65°C  
防护等级 Type of protection: IP44  
绝缘等级 Insulation class: "B"

产品型号 Model	电压 Voltage VDC	电流 Current A	功率 Power W	转速 Speed RPM	风量 Air Flow CFM	静压 Static Pressure mmH <sub>2</sub> O	噪音 Noise dB(A)
YDH220AG24-B01	24	3.4	82	2800	583	57.1	75
YDH220AG48-A01	48	1.7	82	2800	583	57.1	75

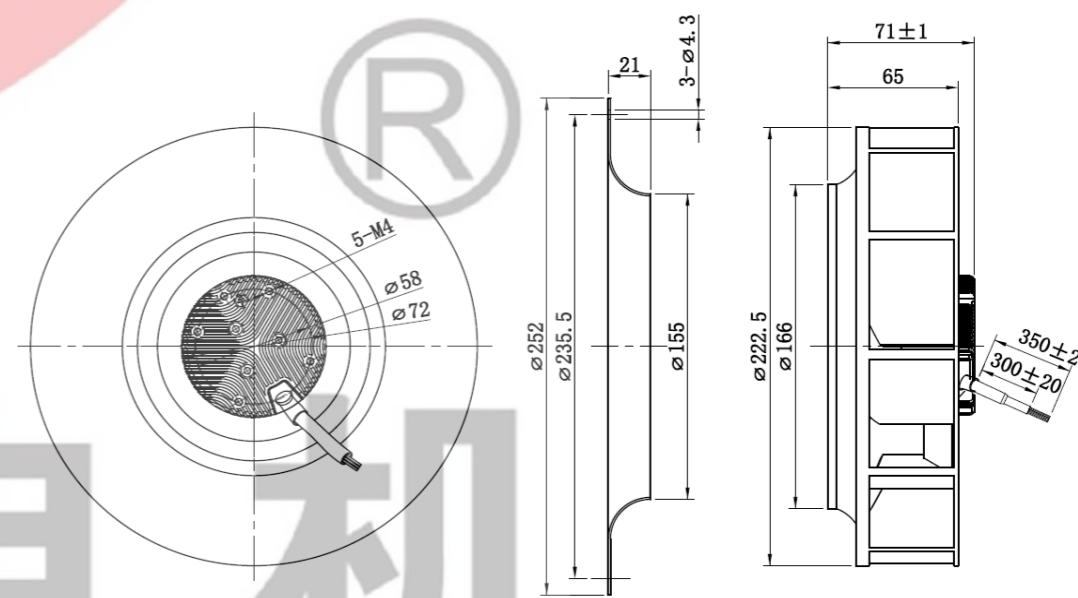
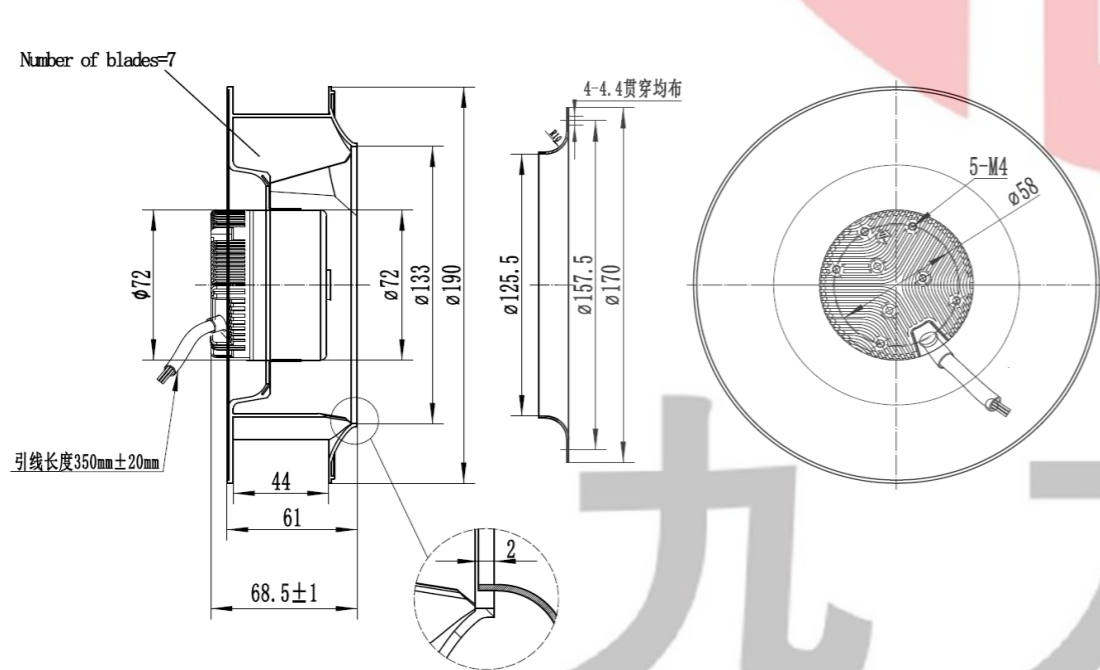

九 龙 电 机

AC Axial Fan  
AC轴流风机

AC All-Metal Axial Fan  
AC全金属轴流风扇

DC Axial Fan  
DC轴流风机

DC Centrifugal Fan  
DC离心风机

EC Axial Fan  
EC轴流风机

EC Centrifugal Fan  
EC离心风机

AC Centrifugal Fan  
AC离心风机

Fan Accessories  
风机配件



JIULONG MOTOR  
AC/DC FANS COOLING FANS

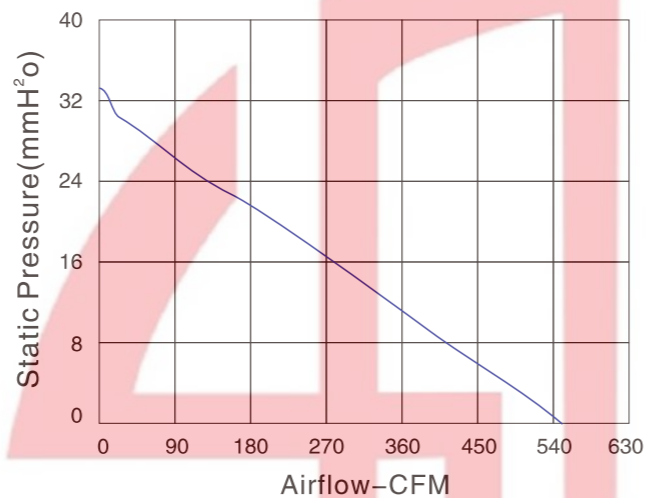

尺寸 Size: Ø220mmX93mm  
风量 Airflow: 543.1CFM  
噪音 Noise: 63dB(A)  
风叶 Impeller Material: ABS+GF  
工作方式 Operation mode: S1  
温度范围 Operating Temperature: -10°C~+65°C  
防护等级 Type of protection: IP44  
绝缘等级 Insulation class: "B"

产品型号 Model	电压 Voltage VDC	电流 Current A	功率 Power W	转速 Speed RPM	风量 Air Flow CFM	静压 Static Pressure mmH <sub>2</sub> O	噪音 Noise dB(A)
YDH220BG24-B01	24	3.5	84	2000	543.1	33.2	63
YDH220BG48-A01	48	1.75	84	2000	543.1	33.2	63

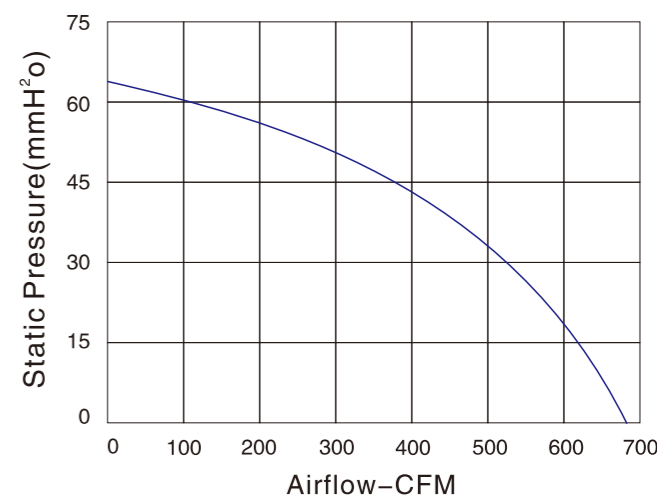

尺寸 Size: Ø225mmX75mm  
风量 Airflow: 683CFM  
噪音 Noise: 73dB(A)  
风叶 Impeller Material: PA66  
工作方式 Operation mode: S1  
温度范围 Operating Temperature: -10°C~+65°C  
防护等级 Type of protection: IP44  
绝缘等级 Insulation class: "B"

产品型号 Model	电压 Voltage VDC	电流 Current A	功率 Power W	转速 Speed RPM	风量 Air Flow CFM	静压 Static Pressure mmH <sub>2</sub> O	噪音 Noise dB(A)
YDH225BG24-B01	24	3.5	85	3000	683	66.3	73
YDH225BG48-A01	48	1.8	85	3000	683	66.3	73

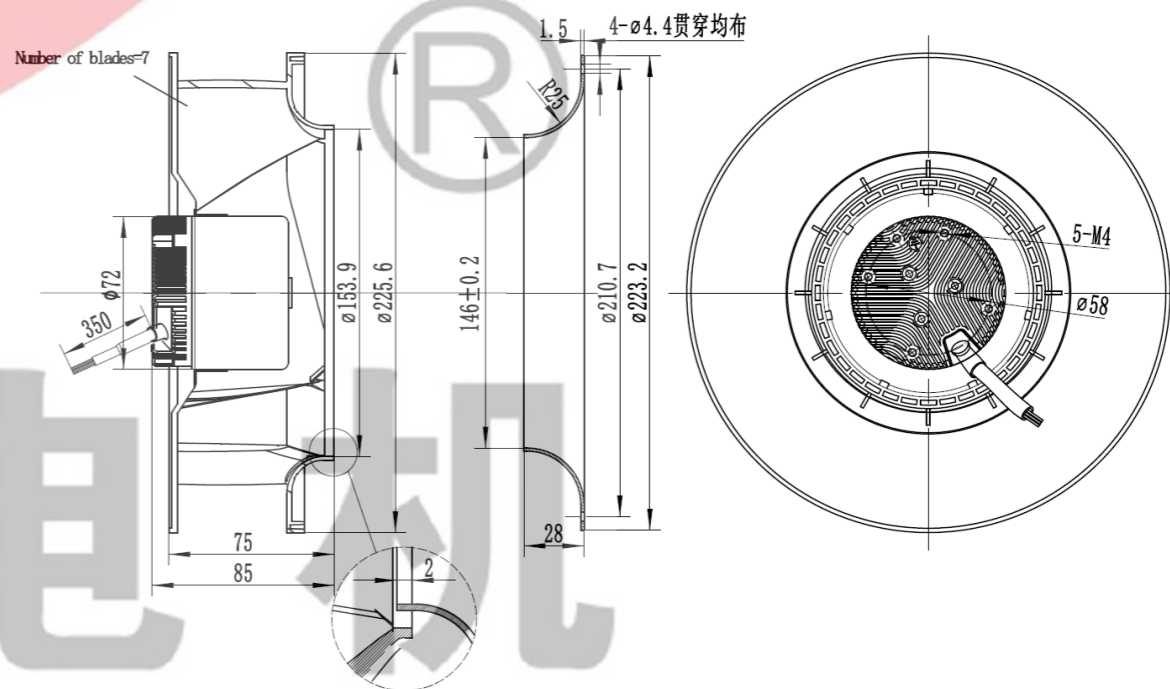
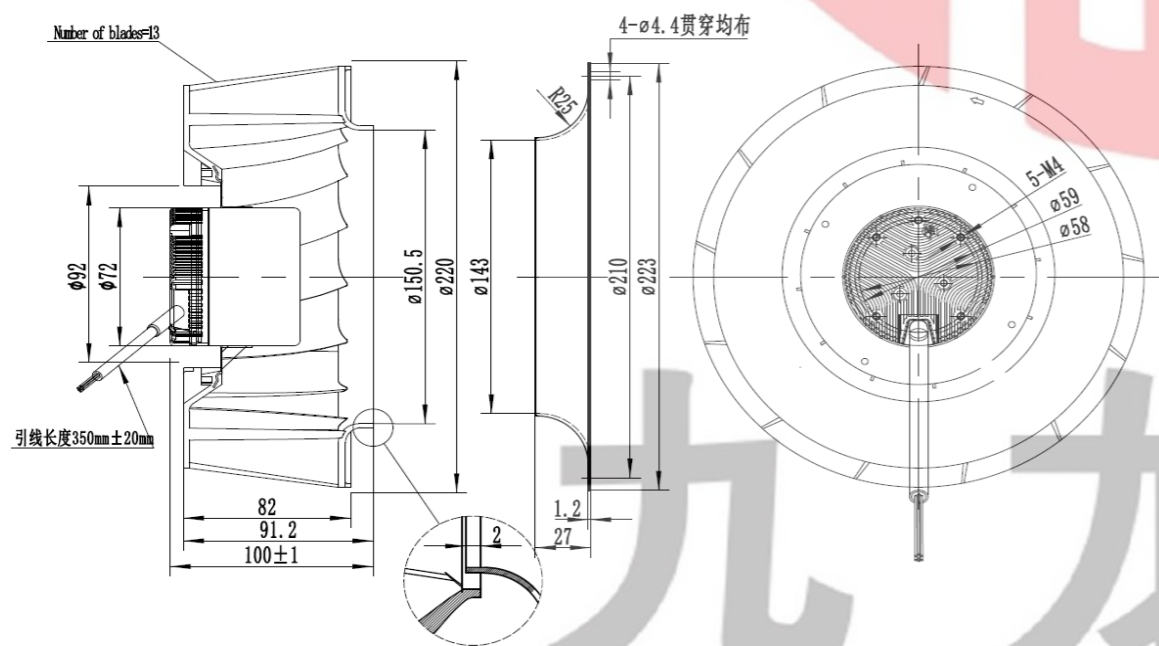



JULONG MOTOR  
AC/DC FANS COOLING FANS



本样图仅供参考，具体以规格书为准。  
This sample book is for reference only. Please refer to the specification for details.  
如需特殊电压也可根据需求提供。本公司保留技术知识产权。  
Special voltage may be provided flexibly according to the requirement. All technical modification rights reserved.

Http://www.xtgygs.cn

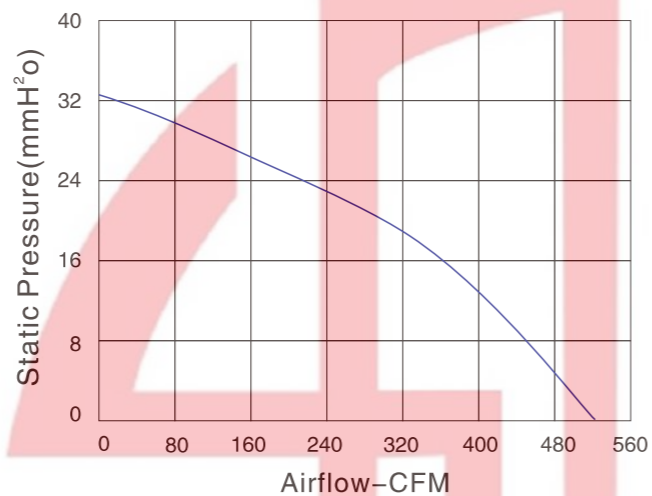

尺寸 Size: Ø225mmX89mm  
风量 Airflow: 733.2CFM  
噪音 Noise: 69.8dB(A)  
风叶 Impeller Material: PA66  
工作方式 Operation mode: S1  
温度范围 Operating Temperature: -10°C~+65°C  
防护等级 Type of protection: IP44  
绝缘等级 Insulation class: "B"

产品型号 Model	电压 Voltage VDC	电流 Current A	功率 Power W	转速 Speed RPM	风量 Air Flow CFM	静压 Static Pressure mmH <sub>2</sub> O	噪音 Noise dB(A)
YDH225CG24-B01	24	2.8	68	2000	543.1	33.2	63
YDH225CG48-A01	48	1.4	68	2000	543.1	33.2	63

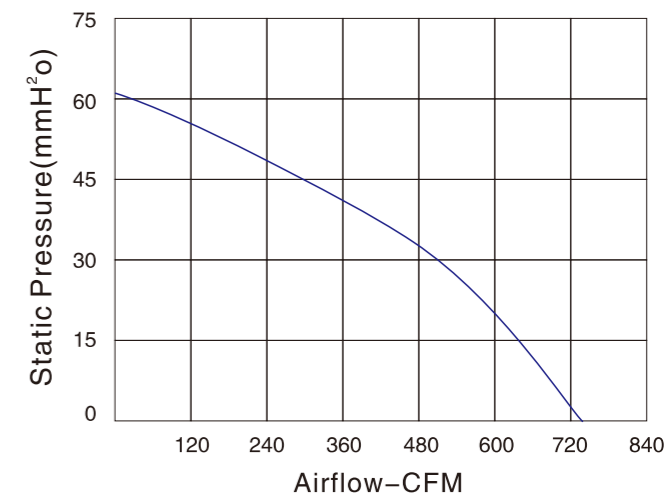

尺寸 Size: Ø225mmX89mm  
风量 Airflow: 733.2CFM  
噪音 Noise: 69.8dB(A)  
风叶 Impeller Material: PA66  
工作方式 Operation mode: S1  
温度范围 Operating Temperature: -10°C~+65°C  
防护等级 Type of protection: IP44  
绝缘等级 Insulation class: "B"

产品型号 Model	电压 Voltage VDC	电流 Current A	功率 Power W	转速 Speed RPM	风量 Air Flow CFM	静压 Static Pressure mmH <sub>2</sub> O	噪音 Noise dB(A)
YDH225CH24-A01	24	5.8	140	2700	733.2	60.5	69.8
YDH225CH48-A01	48	2.9	140	2700	733.2	60.5	69.8

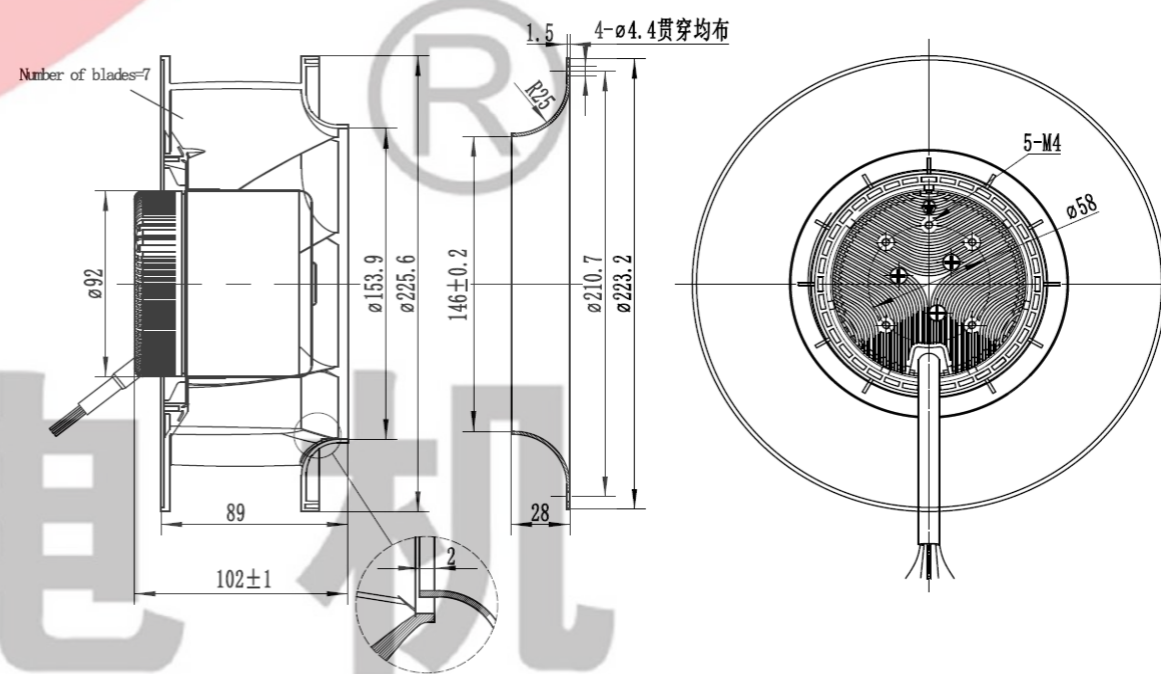
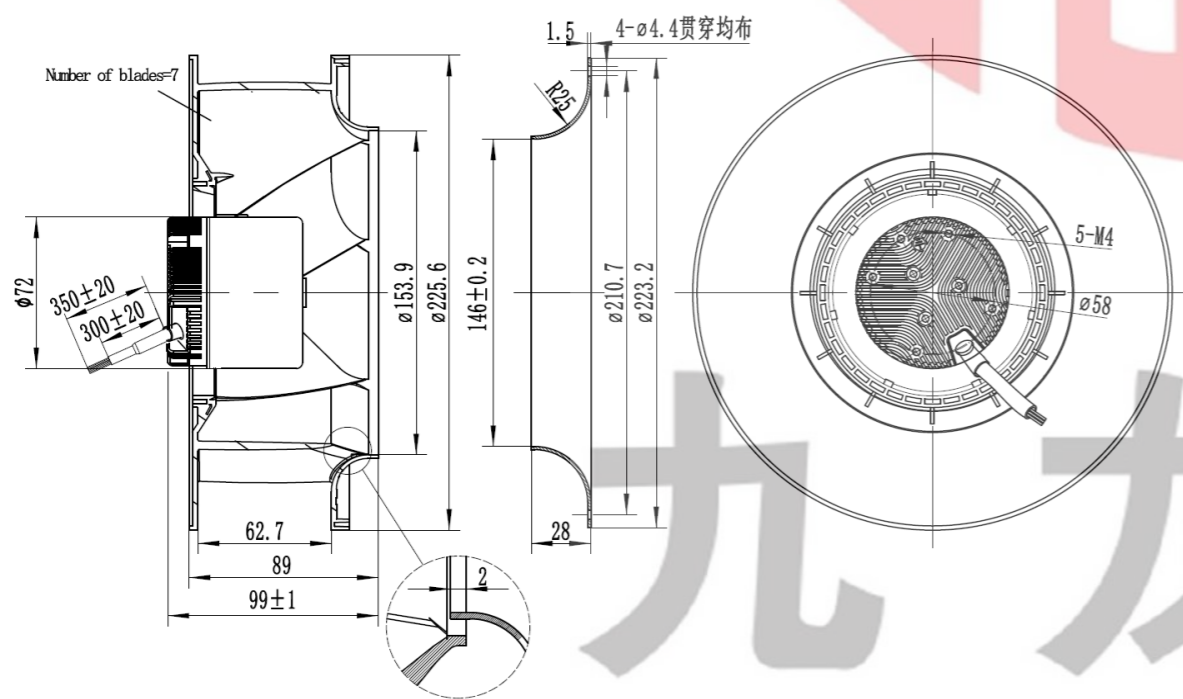

AC Axial Fan  
AC轴流风机

AC All-Metal Axial Fan  
AC全金属轴流风扇

DC Axial Fan  
DC轴流风机

DC Centrifugal Fan  
DC离心风机

EC Axial Fan  
EC轴流风机

EC Centrifugal Fan  
EC离心风机

AC Centrifugal Fan  
AC离心风机

Fan Accessories  
风机配件

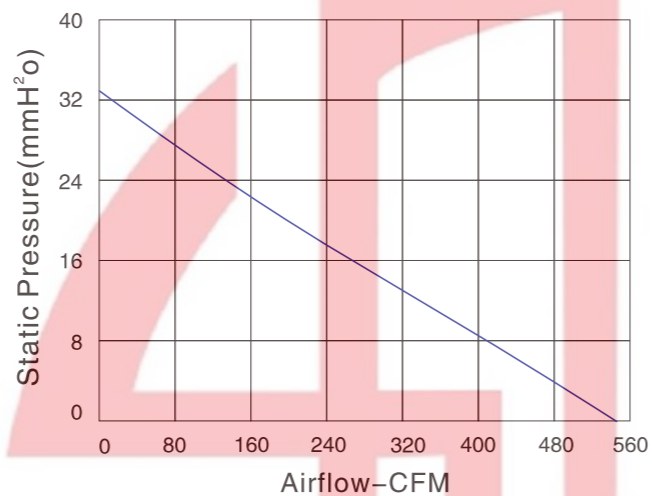

尺寸 Size: Ø225mmX93mm  
风量 Airflow: 543.1CFM  
噪音 Noise: 63dB(A)  
风叶 Impeller Material: ABS+GF  
工作方式 Operation mode: S1  
温度范围 Operating Temperature: -10°C~+65°C  
防护等级 Type of protection: IP44  
绝缘等级 Insulation class: "B"

产品型号 Model	电压 Voltage VDC	电流 Current A	功率 Power W	转速 Speed RPM	风量 Air Flow CFM	静压 Static Pressure mmH <sub>2</sub> O	噪音 Noise dB(A)
YDH225DG24-B01	24	3.5	84	2000	543.1	33.2	63
YDH225DG48-A01	48	1.75	84	2000	543.1	33.2	63

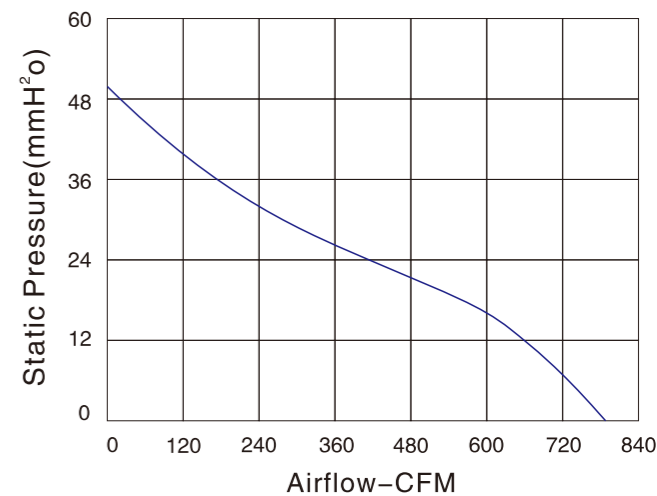
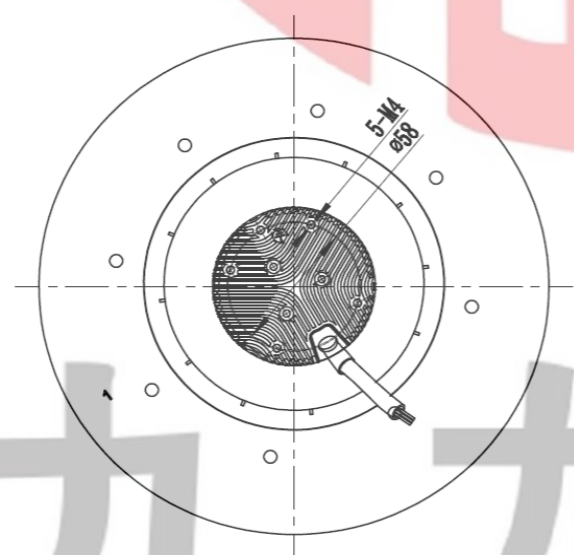
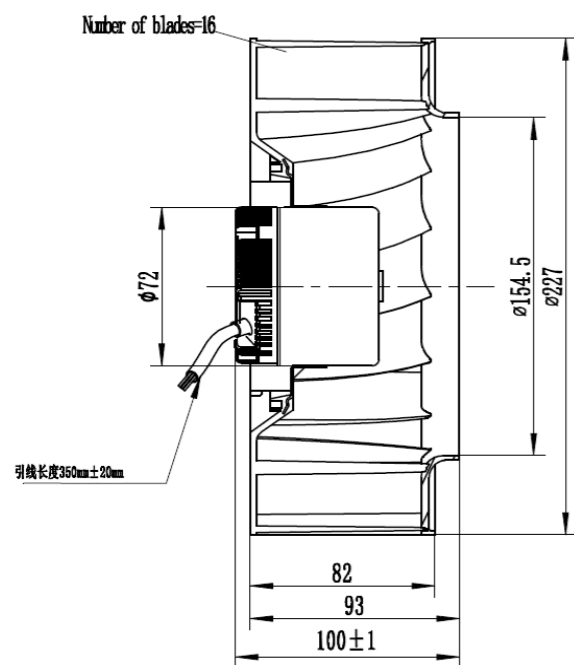

尺寸 Size: Ø250mmX81mm  
风量 Airflow: 788.3CFM  
噪音 Noise: 73.3dB(A)  
风叶 Impeller Material: PA66  
工作方式 Operation mode: S1  
温度范围 Operating Temperature: -10°C~+65°C  
防护等级 Type of protection: IP44  
绝缘等级 Insulation class: "B"

产品型号 Model	电压 Voltage VDC	电流 Current A	功率 Power W	转速 Speed RPM	风量 Air Flow CFM	静压 Static Pressure mmH <sub>2</sub> O	噪音 Noise dB(A)
YDH250AH24-A01	24	4.8	115	2400	788.3	50.4	73.3
YDH250AH48-A01	48	2.4	115	2400	788.3	50.4	73.3

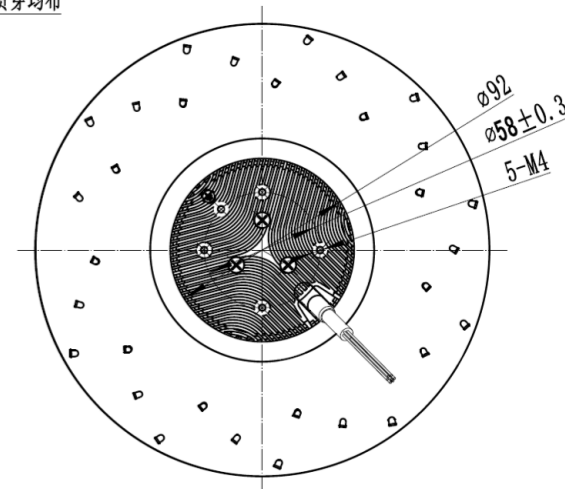
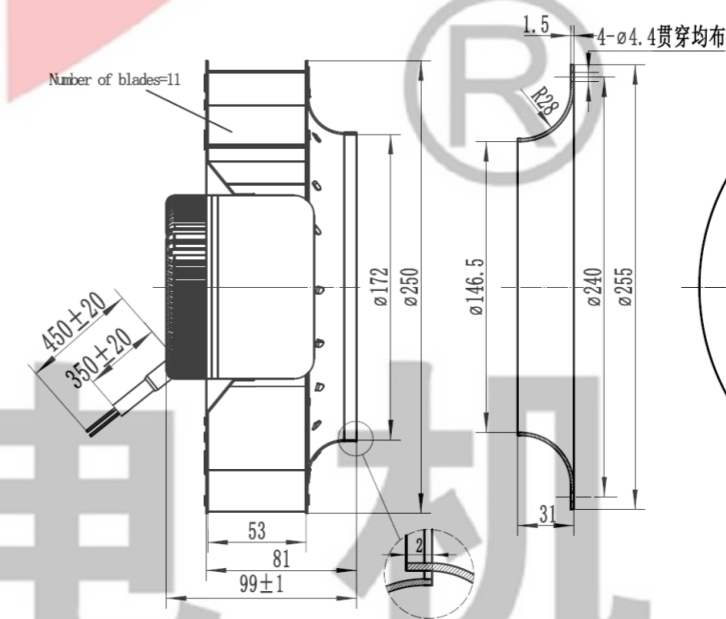

九 龙 电 机



JIULONG MOTOR  
AC/DC FANS COOLING FANS



UL  
E248719



本样机仅供参考，具体以规格书为准。  
This sample book is for reference only. Please refer to the specification for details.  
如需特殊电压也可根据需求提供，本公司保留技术知识产权。  
Special voltage may be provided flexibly according to the requirement. All technical modification rights reserved.

Http://www.xtgygs.cn

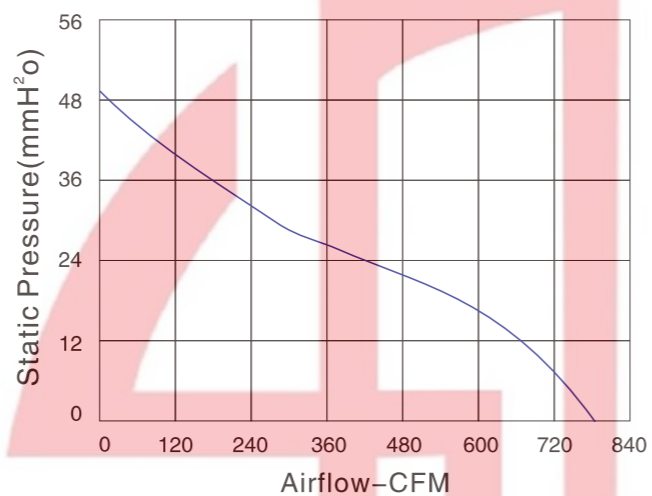

尺寸 Size: Ø250mmX86mm  
风量 Airflow: 788.3CFM  
噪音 Noise: 73.3dB(A)  
风叶 Impeller Material: PA66  
工作方式 Operation mode: S1  
温度范围 Operating Temperature: -10°C~+65°C  
防护等级 Type of protection: IP44  
绝缘等级 Insulation class: "B"

产品型号 Model	电压 Voltage VDC	电流 Current A	功率 Power W	转速 Speed RPM	风量 Air Flow CFM	静压 Static Pressure mmH <sub>2</sub> O	噪音 Noise dB(A)
YDH250BH24-A01	24	3.7	88	2400	788.3	50.4	73.3
YDH250BH48-A01	48	1.8	88	2400	788.3	50.4	73.3

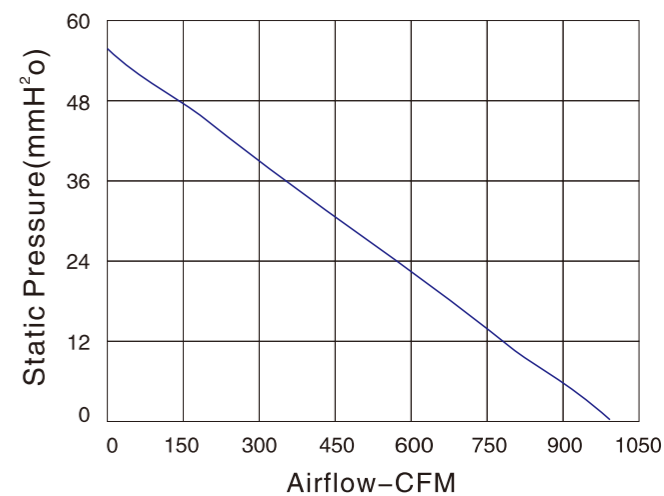
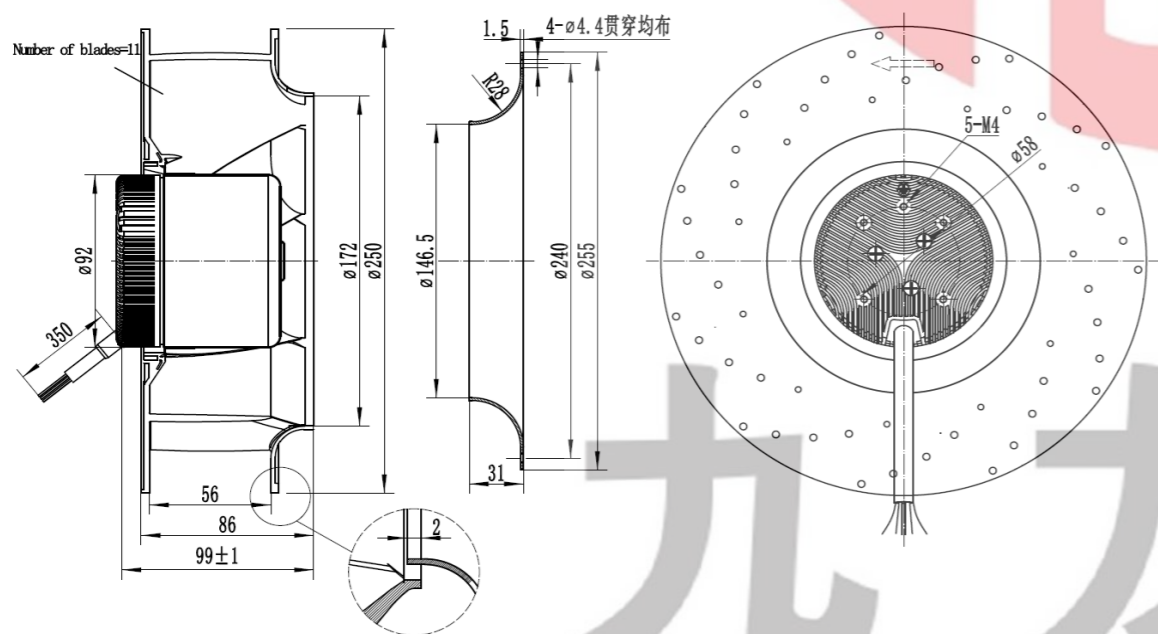

尺寸 Size: Ø280mmX81mm  
风量 Airflow: 990.4CFM  
噪音 Noise: 71.8dB(A)  
风叶 Impeller Material: Metal  
工作方式 Operation mode: S1  
温度范围 Operating Temperature: -10°C~+65°C  
防护等级 Type of protection: IP44  
绝缘等级 Insulation class: "B"

产品型号 Model	电压 Voltage VDC	电流 Current A	功率 Power W	转速 Speed RPM	风量 Air Flow CFM	静压 Static Pressure mmH <sub>2</sub> O	噪音 Noise dB(A)
YDH280AH24-A01	24	4.3	105	2200	990.4	55.4	71.8
YDH280AH48-A01	48	2.2	105	2200	990.4	55.4	71.8

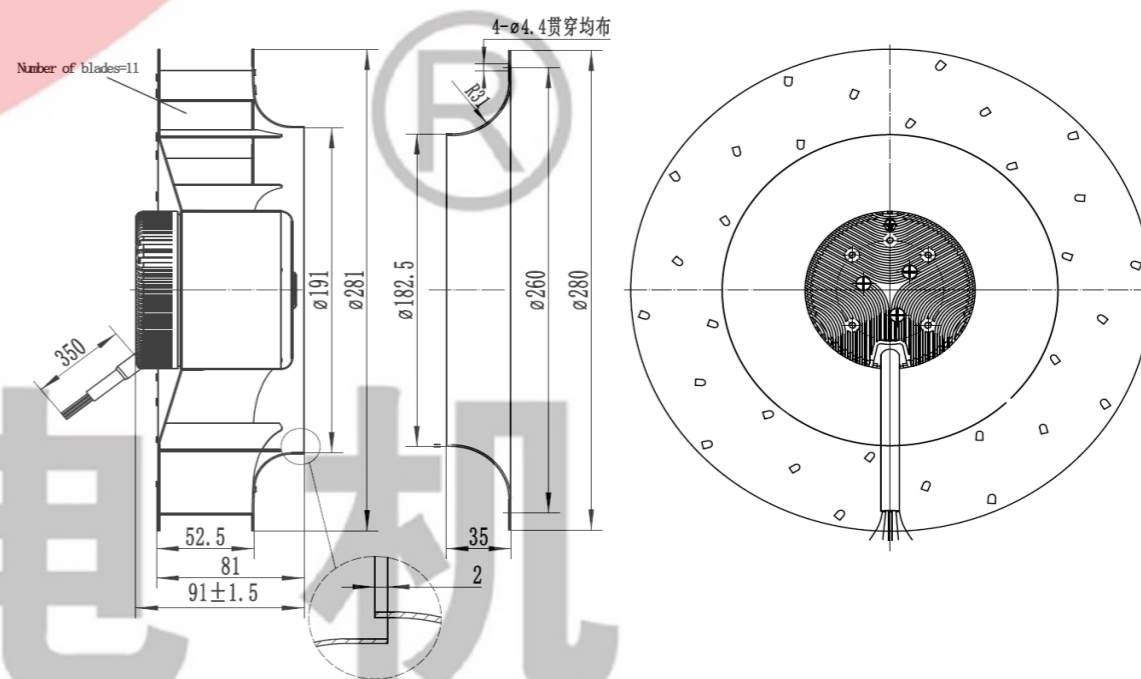

AC Axial Fan  
AC轴流风机

AC All-Metal Axial Fan  
AC全金属轴流风扇

DC Axial Fan  
DC轴流风机

DC Centrifugal Fan  
DC离心风机

EC Axial Fan  
EC轴流风机

EC Centrifugal Fan  
EC离心风机

AC Centrifugal Fan  
AC离心风机

Fan Accessories  
风机配件

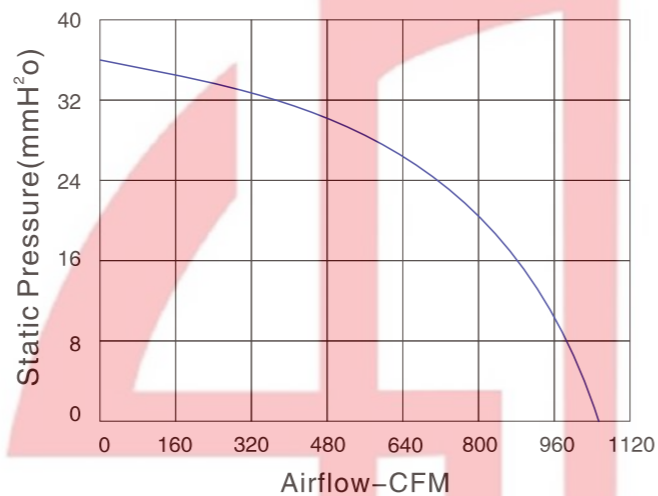

尺寸 Size: Ø280mmX112mm  
风量 Airflow: 1051CFM  
噪音 Noise: 67.9dB(A)  
风叶 Impeller Material: Metal  
工作方式 Operation mode: S1  
温度范围 Operating Temperature: -10°C~+65°C  
防护等级 Type of protection: IP44  
绝缘等级 Insulation class: "B"

产品型号 Model	电压 Voltage VDC	电流 Current A	功率 Power W	转速 Speed RPM	风量 Air Flow CFM	静压 Static Pressure mmH <sub>2</sub> O	噪音 Noise dB(A)
YDH280BH24-A01	24	4.8	115	1800	1051	36.4	67.9
YDH280BH48-A01	48	2.4	115	1800	1051	36.4	67.9

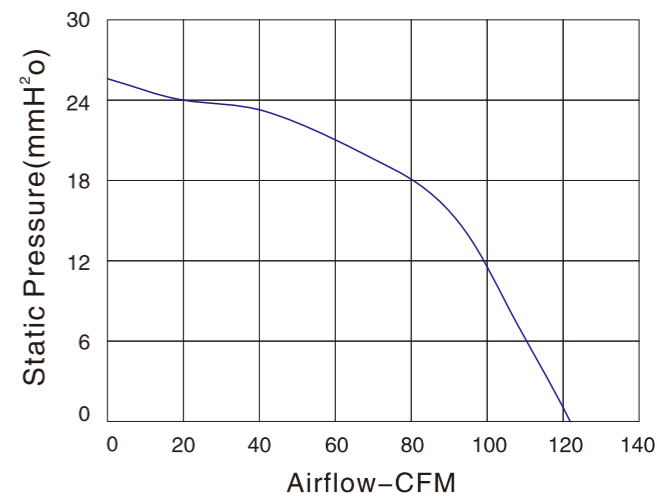
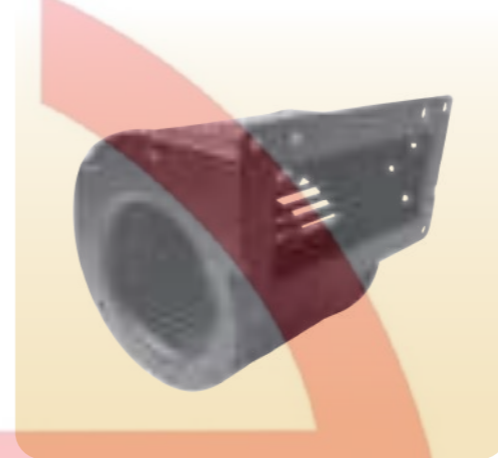

尺寸 Size: Ø97mmX85mm  
风量 Airflow: 93.6CFM  
噪音 Noise: 57dB(A)  
风叶 Impeller Material: Metal  
工作方式 Operation mode: S1  
温度范围 Operating Temperature: -10°C~+65°C  
防护等级 Type of protection: IP44  
绝缘等级 Insulation class: "B"

产品型号 Model	电压 Voltage VDC	电流 Current A	功率 Power W	转速 Speed RPM	风量 Air Flow CFM	静压 Static Pressure mmH <sub>2</sub> O	噪音 Noise dB(A)
YDS097AE24-A01-W	24	1.4	34	2500	120.5	26.5	57
YDS097AE48-A01-W	48	0.7	34	2500	120.5	26.5	57

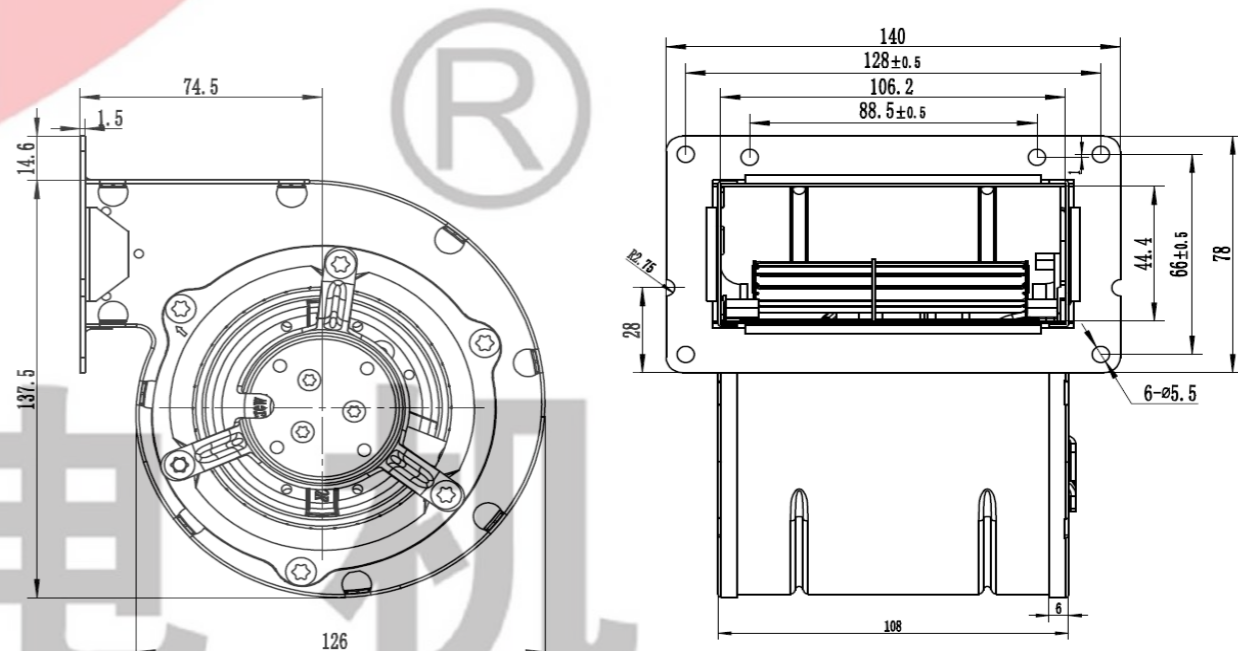
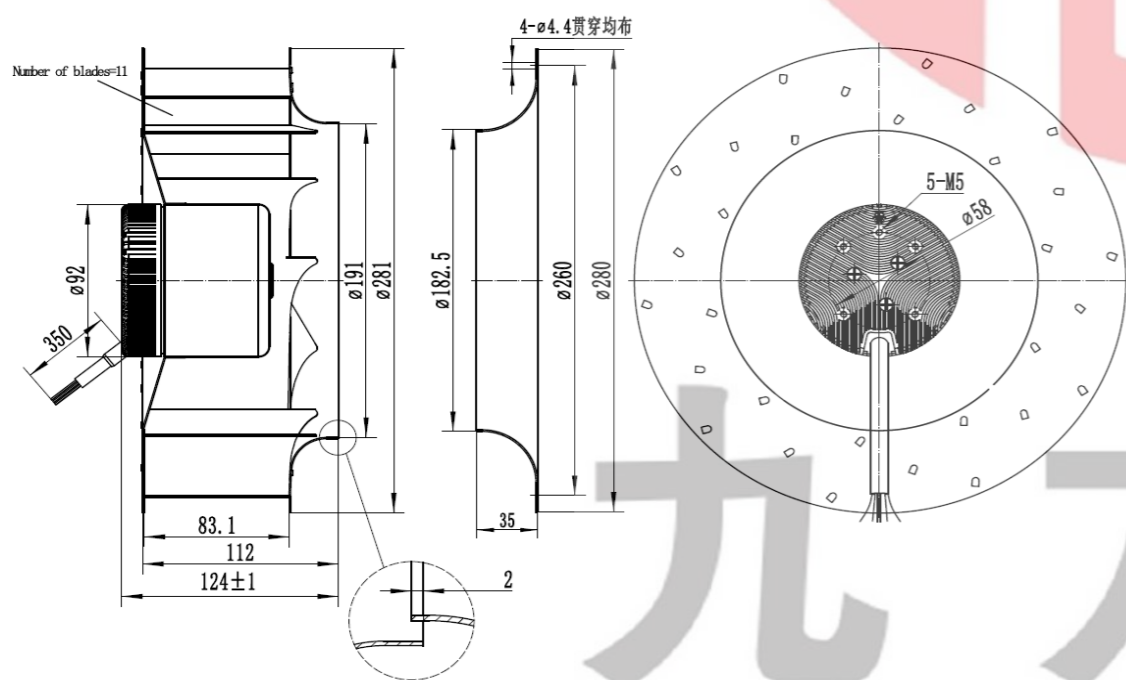

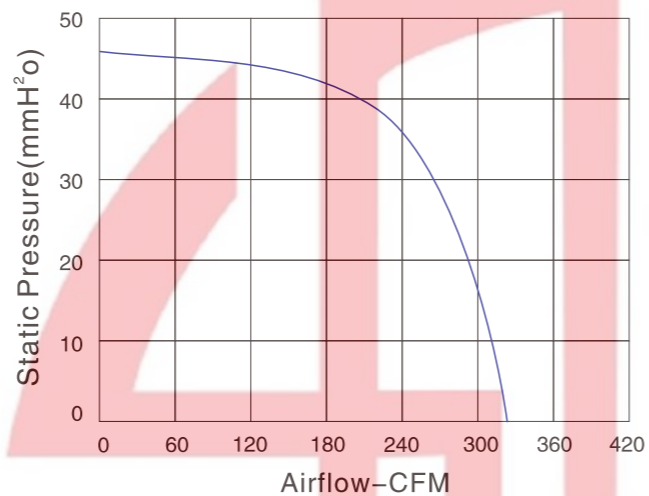

尺寸 Size: Ø120mmX122mm  
风量 Airflow: 323.5CFM  
噪音 Noise: 62.2dB(A)  
风叶 Impeller Material: Metal  
工作方式 Operation mode: S1  
温度范围 Operating Temperature: -10°C~+65°C  
防护等级 Type of protection: IP44  
绝缘等级 Insulation class: "B"

产品型号 Model	电压 Voltage VDC	电流 Current A	功率 Power W	转速 Speed RPM	风量 Air Flow CFM	静压 Static Pressure mmH <sub>2</sub> O	噪音 Noise dB(A)
YDS120BG24-B01-W	24	3.9	94	2000	323.5	46.1	62.3
YDS120BG48-A01-W	48	1.9	94	2000	323.5	46.1	62.3

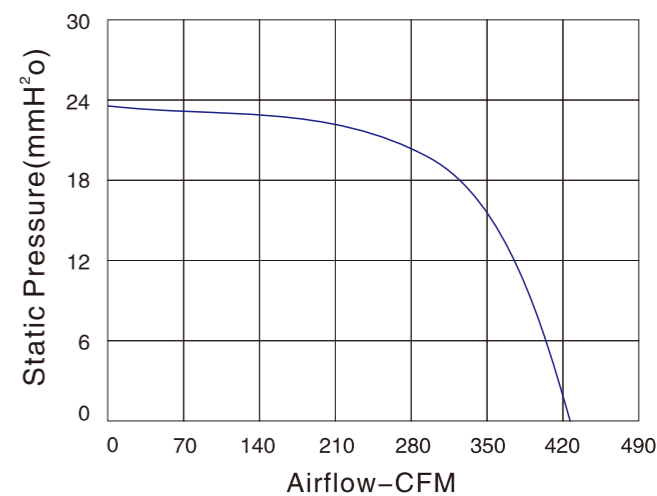

尺寸 Size: Ø133mmX190mm  
风量 Airflow: 427.8CFM  
噪音 Noise: 56.7dB(A)  
风叶 Impeller Material: Metal  
工作方式 Operation mode: S1  
温度范围 Operating Temperature: -10°C~+65°C  
防护等级 Type of protection: IP44  
绝缘等级 Insulation class: "B"

产品型号 Model	电压 Voltage VDC	电流 Current A	功率 Power W	转速 Speed RPM	风量 Air Flow CFM	静压 Static Pressure mmH <sub>2</sub> O	噪音 Noise dB(A)
YDS133BG24-B01-W	24	4.5	108	1600	427.8	23.7	56.7
YDS133BG48-A01-W	48	2.3	108	1600	427.8	23.7	56.7

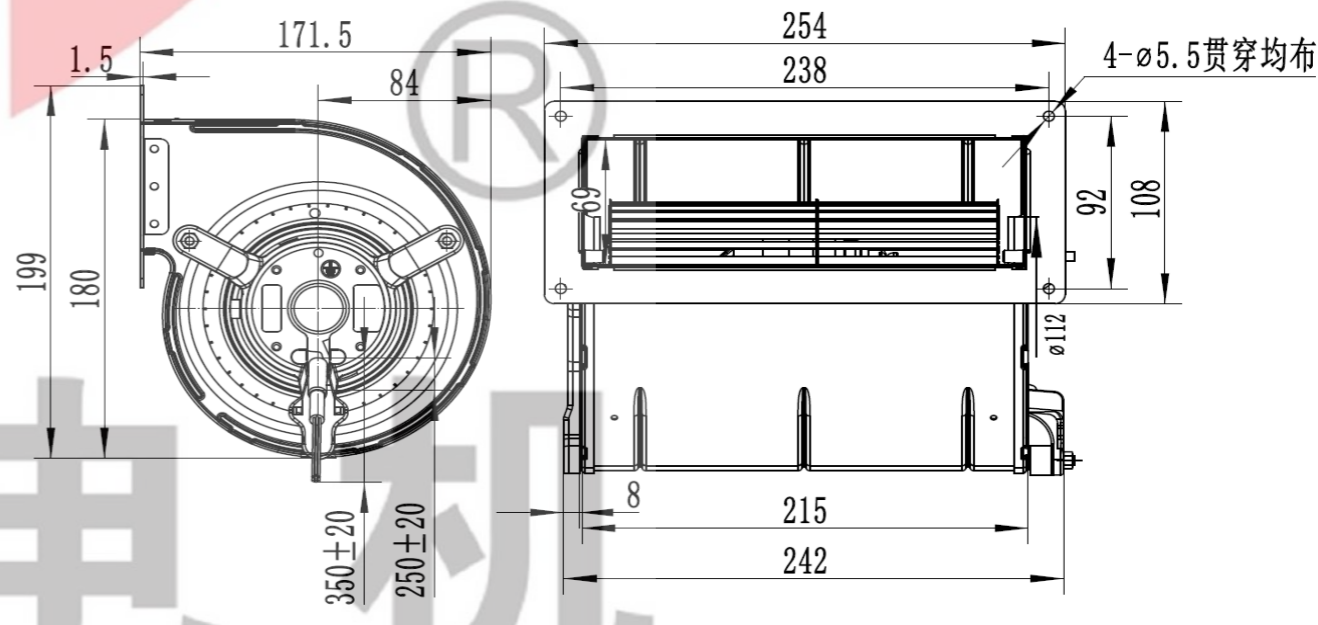
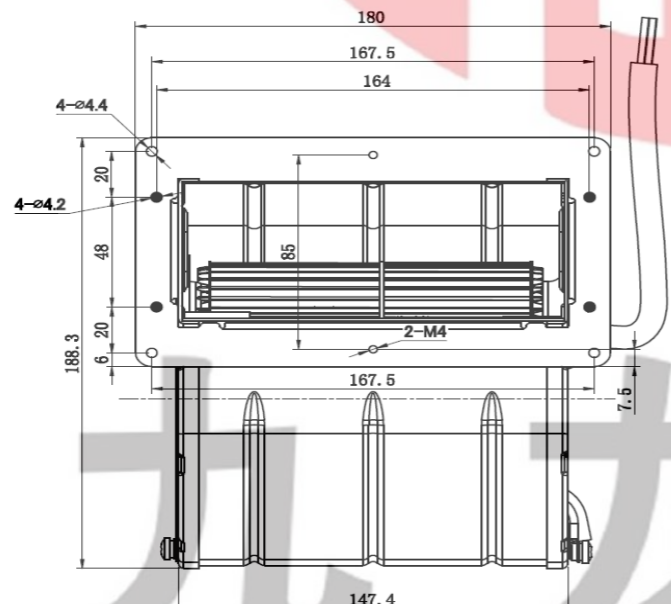
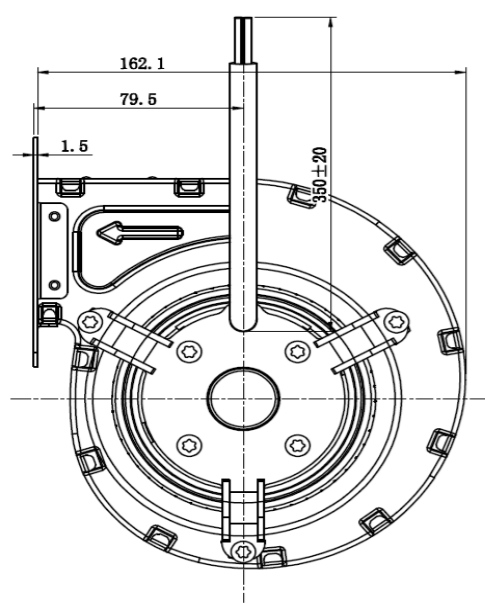

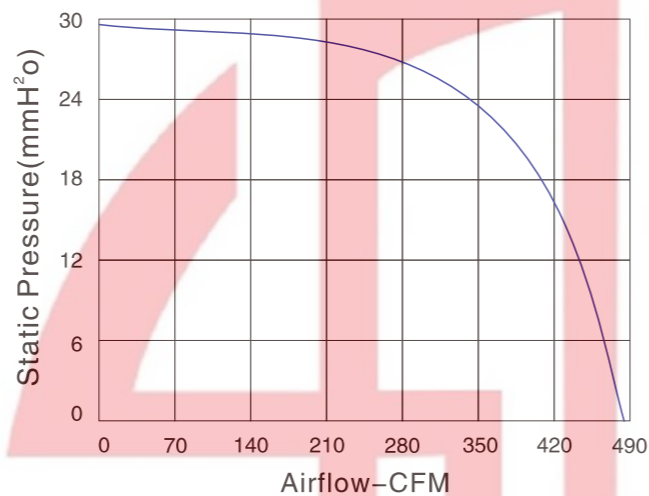

尺寸 Size: Ø133mmX190mm  
风量 Airflow: 481.3CFM  
噪音 Noise: 59.3dB(A)  
风叶 Impeller Material: Metal  
工作方式 Operation mode: S1  
温度范围 Operating Temperature: -10°C~+65°C  
防护等级 Type of protection: IP44  
绝缘等级 Insulation class: "B"

产品型号 Model	电压 Voltage VDC	电流 Current A	功率 Power W	转速 Speed RPM	风量 Air Flow CFM	静压 Static Pressure mmH <sub>2</sub> O	噪音 Noise dB(A)
YDS133BH24-A01-W	24	6.6	158	1800	481.3	30	59.3
YDS133BH48-A01-W	48	3.3	158	1800	481.3	30	59.3

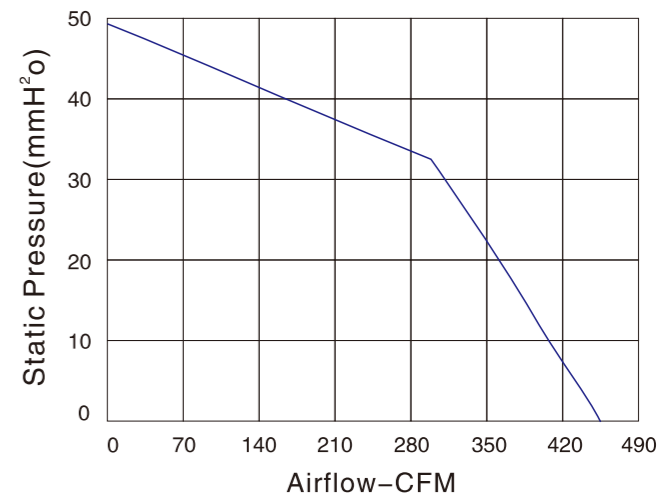
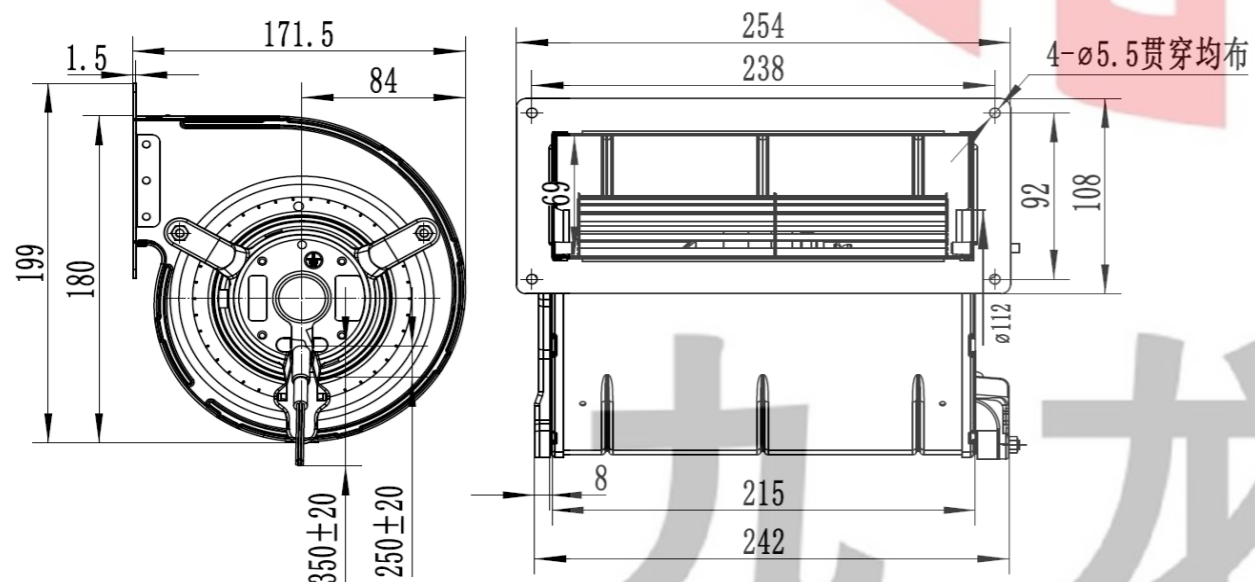

尺寸 Size: Ø146mmX150mm  
风量 Airflow: 459.6CFM  
噪音 Noise: 50.5dB(A)  
风叶 Impeller Material: PP  
工作方式 Operation mode: S1  
温度范围 Operating Temperature: -10°C~+65°C  
防护等级 Type of protection: IP44  
绝缘等级 Insulation class: "B"

产品型号 Model	电压 Voltage VDC	电流 Current A	功率 Power W	转速 Speed RPM	风量 Air Flow CFM	静压 Static Pressure mmH <sub>2</sub> O	噪音 Noise dB(A)
YDS146AG24-B01-W	24	4.8	115	1600	459.6	49.6	50.5
YDS146AG48-A01-W	48	2.4	115	1600	459.6	49.6	50.5

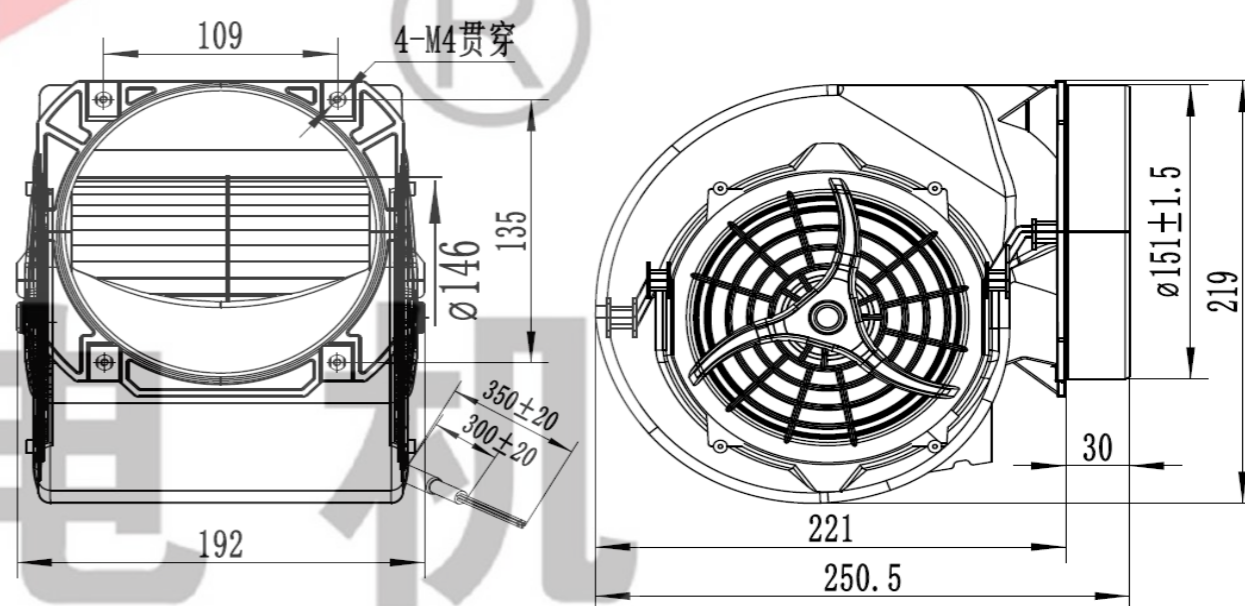

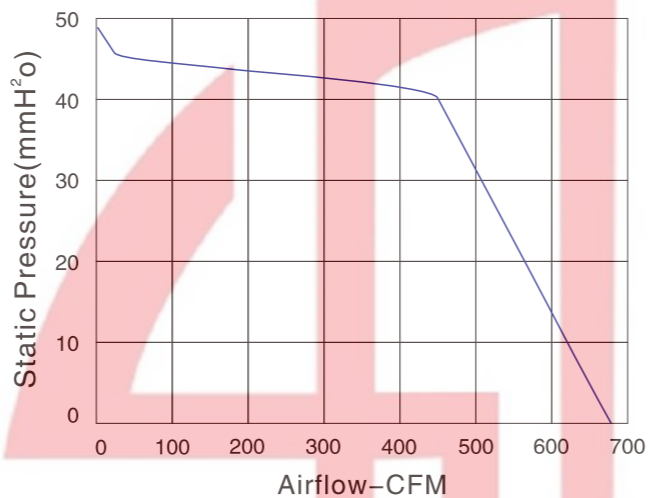

尺寸 Size: Ø146mmX150mm  
风量 Airflow: 671.2CFM  
噪音 Noise: 68dB(A)  
风叶 Impeller Material: PP  
工作方式 Operation mode: S1  
温度范围 Operating Temperature: -10°C~+65°C  
防护等级 Type of protection: IP44  
绝缘等级 Insulation class: "B"

产品型号 Model	电压 Voltage VDC	电流 Current A	功率 Power W	转速 Speed RPM	风量 Air Flow CFM	静压 Static Pressure mmH <sub>2</sub> O	噪音 Noise dB(A)
YDS146AH24-A01-W	24	7.5	180	2000	671.2	45.9	68
YDS146AH48-A01-W	48	3.8	180	2000	671.2	45.9	68

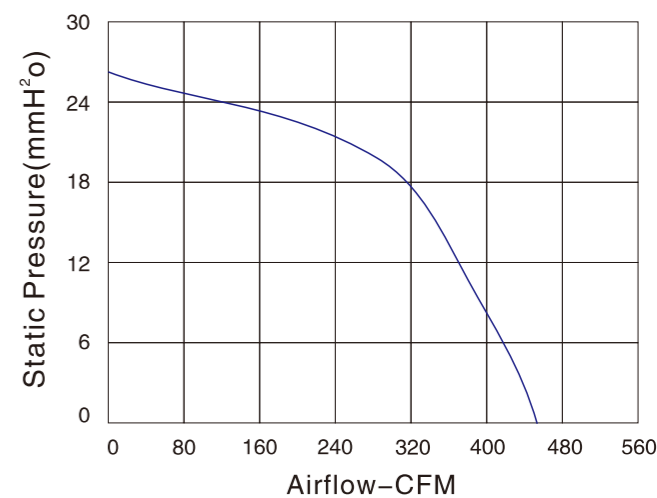
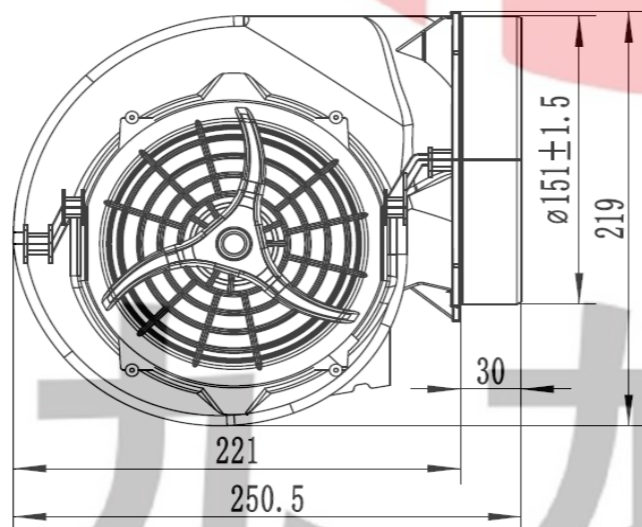
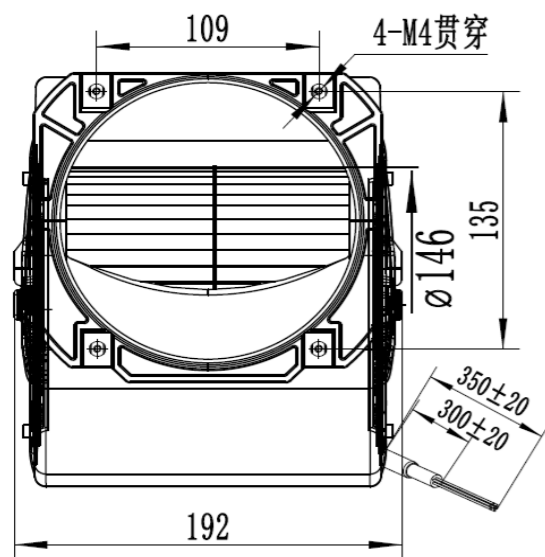

尺寸 Size: Ø146mmX190mm  
风量 Airflow: 453CFM  
噪音 Noise: 61dB(A)  
风叶 Impeller Material: Metal  
工作方式 Operation mode: S1  
温度范围 Operating Temperature: -10°C~+65°C  
防护等级 Type of protection: IP44  
绝缘等级 Insulation class: "B"

产品型号 Model	电压 Voltage VDC	电流 Current A	功率 Power W	转速 Speed RPM	风量 Air Flow CFM	静压 Static Pressure mmH <sub>2</sub> O	噪音 Noise dB(A)
YDS146BG24-B01-W	24	4.9	118	1350	453	26.4	61
YDS146BG48-A01-W	48	2.5	118	1350	453	26.4	61

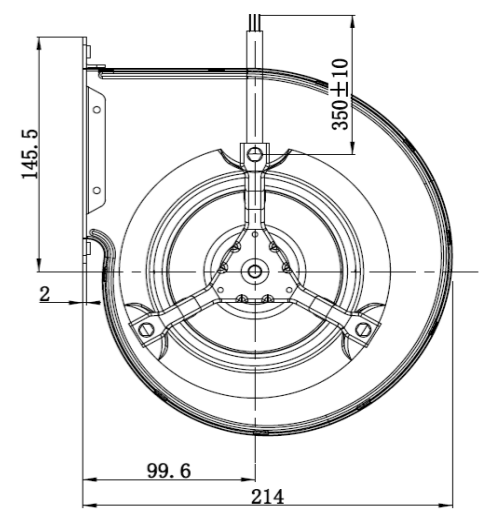
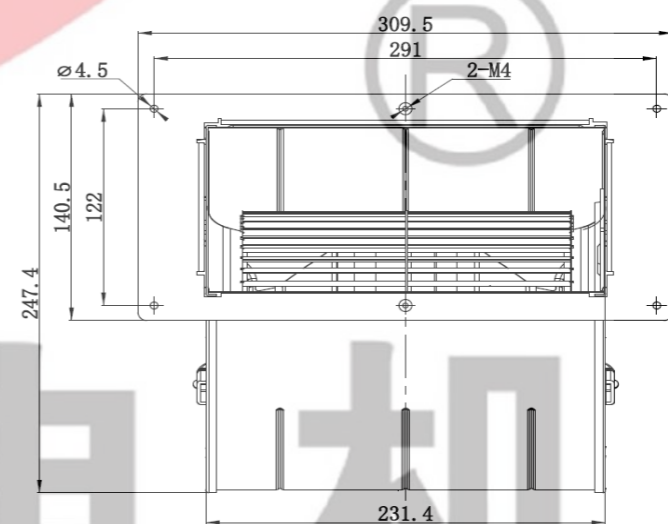

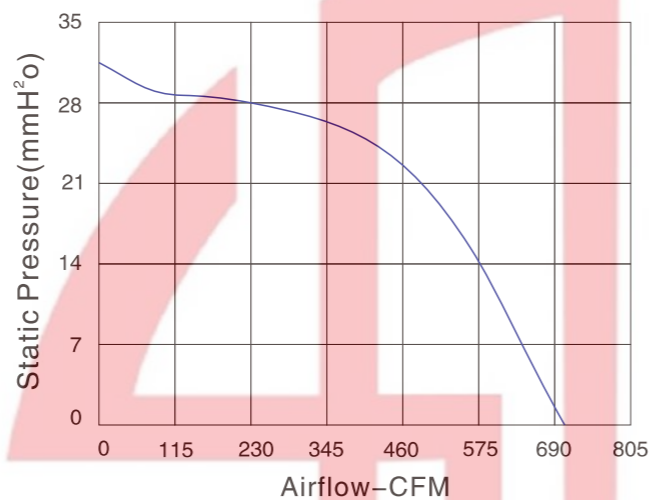

尺寸 Size: Ø146mmX190mm  
风量 Airflow: 713CFM  
噪音 Noise: 63.5dB(A)  
风叶 Impeller Material: Metal  
工作方式 Operation mode: S1  
温度范围 Operating Temperature: -10°C~+65°C  
防护等级 Type of protection: IP44  
绝缘等级 Insulation class: "B"

产品型号 Model	电压 Voltage VDC	电流 Current A	功率 Power W	转速 Speed RPM	风量 Air Flow CFM	静压 Static Pressure mmH <sub>2</sub> O	噪音 Noise dB(A)
YDS146BH24-A01-W	24	8.3	200	1700	713	33	63.5
YDS146BH48-A01-W	48	4.2	200	1700	713	33	63.5

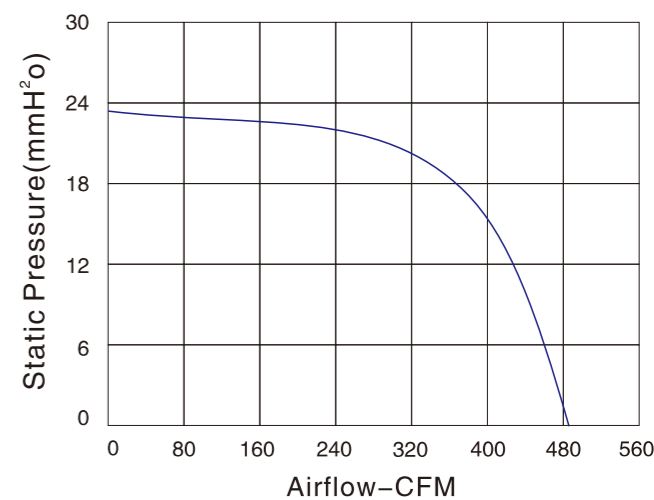
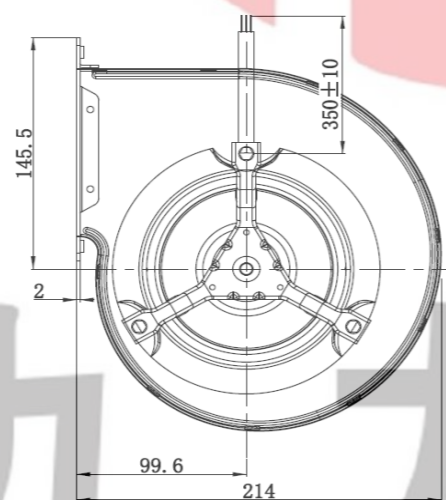
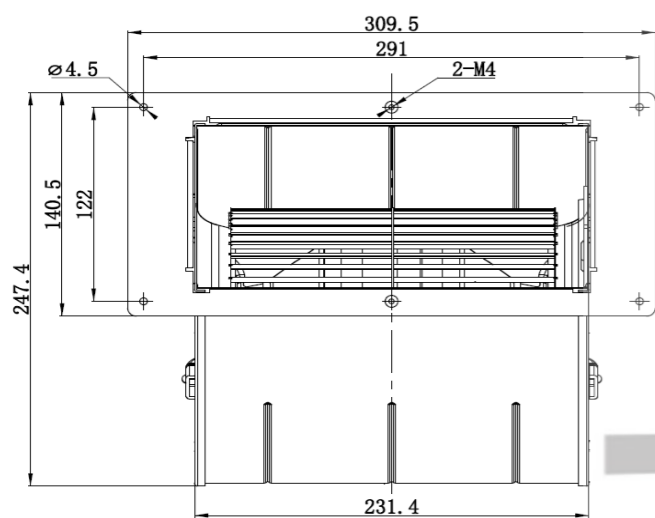

尺寸 Size: Ø151mmX195mm  
风量 Airflow: 481CFM  
噪音 Noise: 57.9dB(A)  
风叶 Impeller Material: Metal  
工作方式 Operation mode: S1  
温度范围 Operating Temperature: -10°C~+65°C  
防护等级 Type of protection: IP44  
绝缘等级 Insulation class: "B"

产品型号 Model	电压 Voltage VDC	电流 Current A	功率 Power W	转速 Speed RPM	风量 Air Flow CFM	静压 Static Pressure mmH <sub>2</sub> O	噪音 Noise dB(A)
YDS151AH24-B01-W	24	4.9	118	1200	481	23	57.9
YDS151AH48-A01-W	48	2.5	118	1200	481	23	57.9

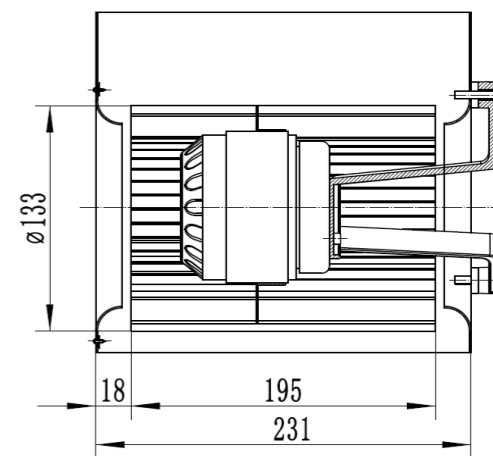
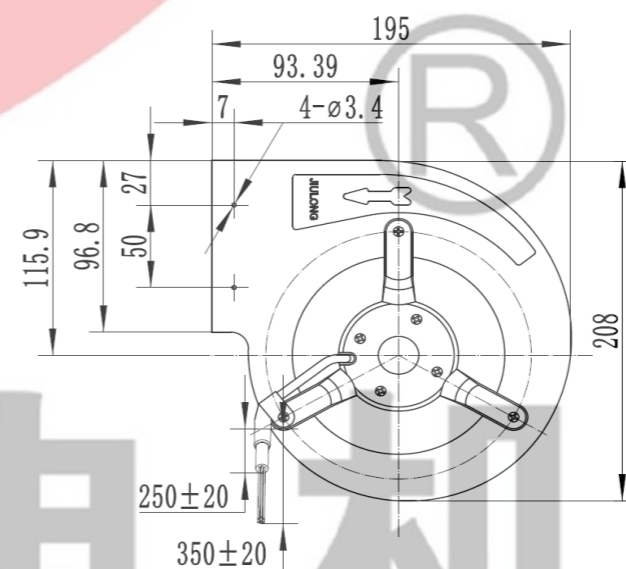

九 龙 电 机

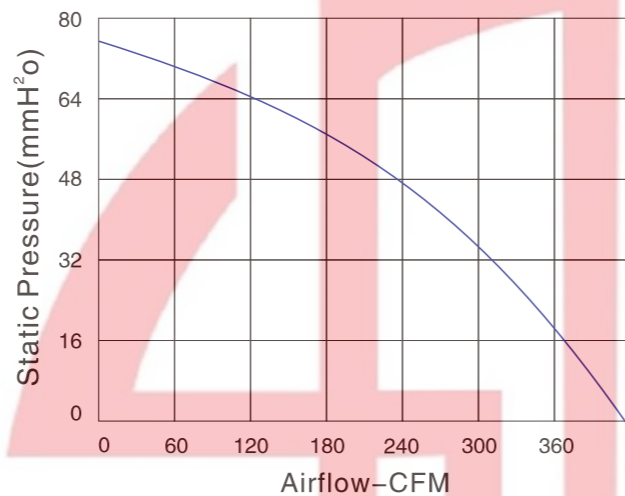

尺寸 Size: Ø160mmX75mm  
风量 Airflow: 412.4CFM  
噪音 Noise: 59.5dB(A)  
风叶 Impeller Material: Metal  
工作方式 Operation mode: S1  
温度范围 Operating Temperature: -10°C~+65°C  
防护等级 Type of protection: IP44  
绝缘等级 Insulation class: "B"

产品型号 Model	电压 Voltage VDC	电流 Current A	功率 Power W	转速 Speed RPM	风量 Air Flow CFM	静压 Static Pressure mmH <sub>2</sub> O	噪音 Noise dB(A)
YDS160AH24-B01-W	24	4.6	110	1400	412.4	75.4	59.5
YDS160AH48-A01-W	48	2.3	110	1400	412.4	75.4	59.5

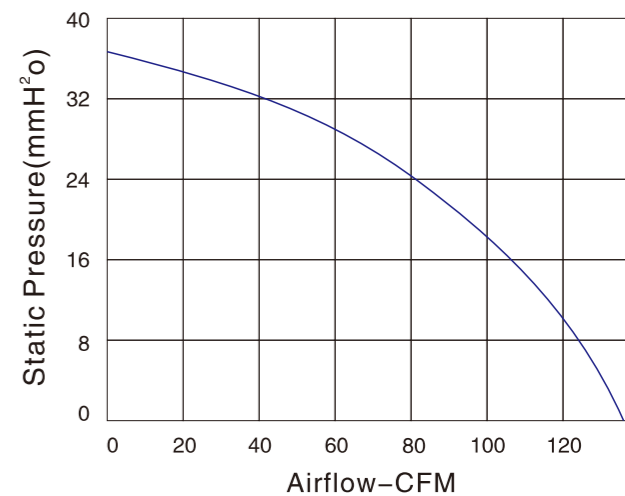
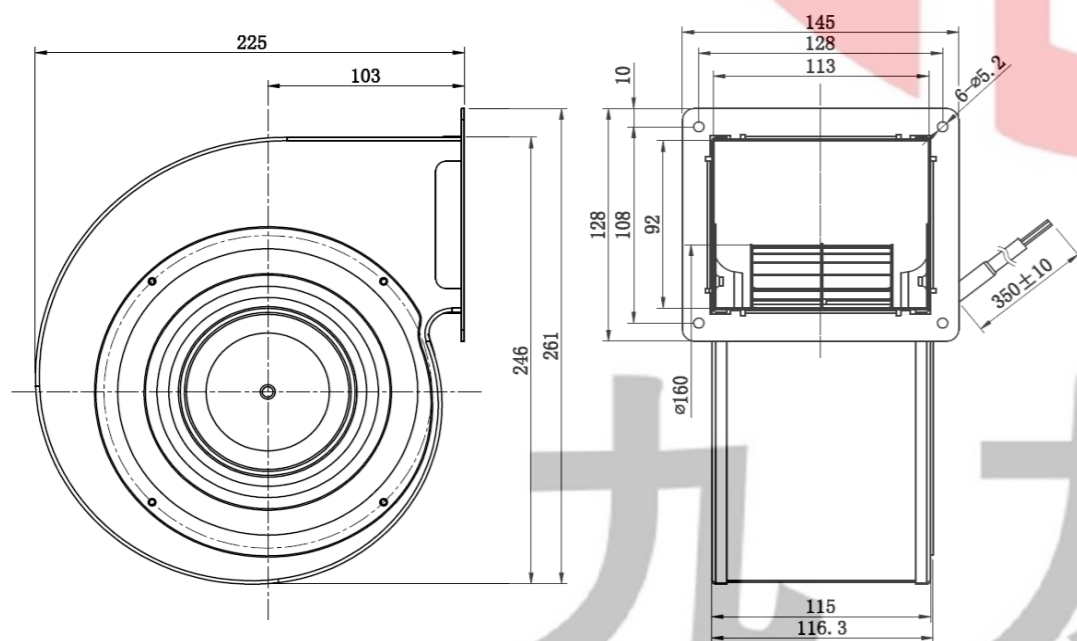

尺寸 Size: Ø108mmX62mm  
风量 Airflow: 136.2CFM  
噪音 Noise: 63.2dB(A)  
风叶 Impeller Material: Metal  
工作方式 Operation mode: S1  
温度范围 Operating Temperature: -10°C~+65°C  
防护等级 Type of protection: IP44  
绝缘等级 Insulation class: "B"

产品型号 Model	电压 Voltage VDC	电流 Current A	功率 Power W	转速 Speed RPM	风量 Air Flow CFM	静压 Static Pressure mmH <sub>2</sub> O	噪音 Noise dB(A)
YDD108AGD3-C01-W	310	0.18	57	2800	136.2	37.9	63.2

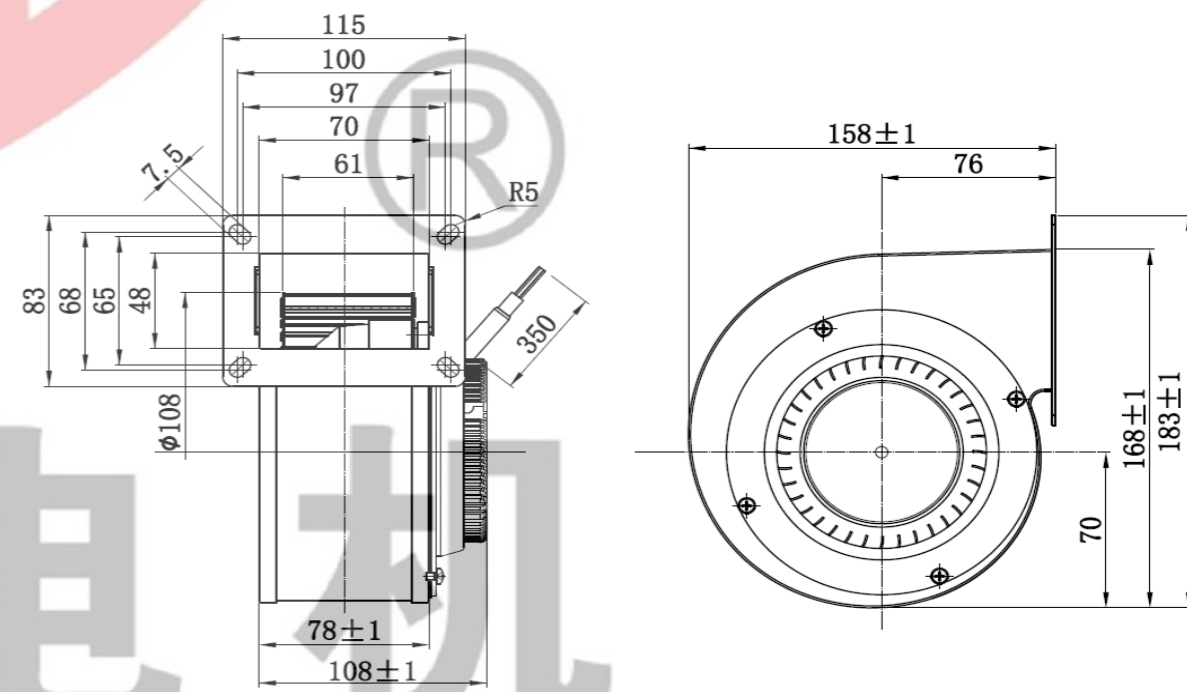



JULONG MOTOR  
AC/DC FANS COOLING FANS



本样图仅供参考，具体以实物为准。  
This sample book is for reference only. Please refer to the specification for details.  
如需特殊电压也可特别定制提供。本公司保留技术改动权利。  
Special voltage may be provided flexibly according to the enquiry. All technical modification rights reserved.

Http://www.xtgygs.cn

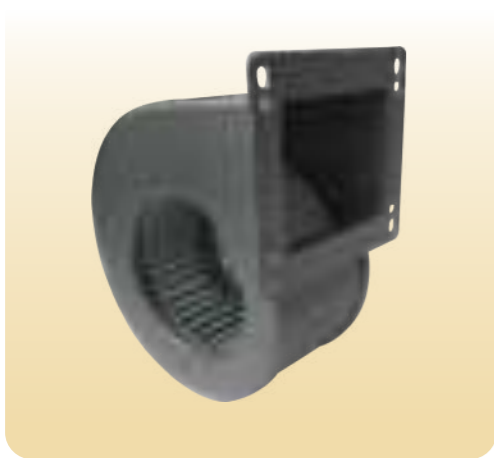

尺寸 Size:  $\varnothing 120\text{mm} \times 62\text{mm}$   
风量 Airflow: 172CFM  
噪音 Noise: 57.8dB(A)  
风叶 Impeller Material: Metal  
工作方式 Operation mode: S1  
温度范围 Operating Temperature:  $-10^{\circ}\text{C} \sim +65^{\circ}\text{C}$   
防护等级 Type of protection: IP44  
绝缘等级 Insulation class: "B"

产品型号 Model	电压 Voltage VDC	电流 Current A	功率 Power W	转速 Speed RPM	风量 Air Flow CFM	静压 Static Pressure mmH <sub>2</sub> O	噪音 Noise dB(A)
YDD120BGD3-C01-W	310	0.17	54	2400	172	24.5	57.8

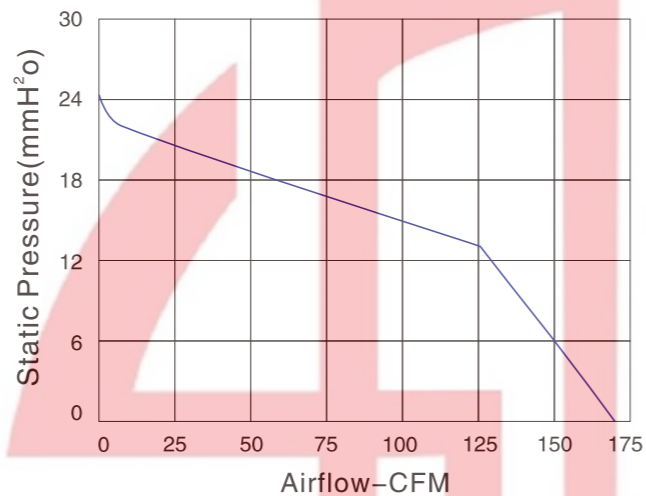

尺寸 Size:  $\varnothing 133\text{mm} \times 50\text{mm}$   
风量 Airflow: 183.6CFM  
噪音 Noise: 60dB(A)  
风叶 Impeller Material: Metal  
工作方式 Operation mode: S1  
温度范围 Operating Temperature:  $-10^{\circ}\text{C} \sim +65^{\circ}\text{C}$   
防护等级 Type of protection: IP44  
绝缘等级 Insulation class: "B"

产品型号 Model	电压 Voltage VDC	电流 Current A	功率 Power W	转速 Speed RPM	风量 Air Flow CFM	静压 Static Pressure mmH <sub>2</sub> O	噪音 Noise dB(A)
YDD133AGD3-C01-W	310	0.28	87	2400	183.6	31.2	60

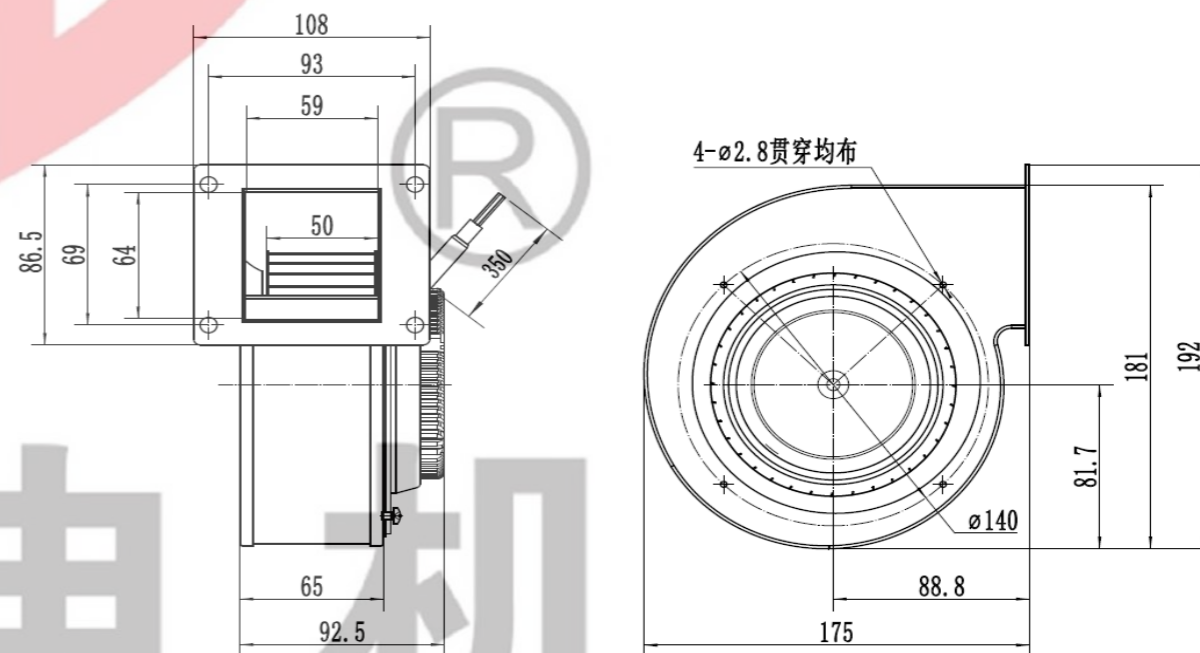
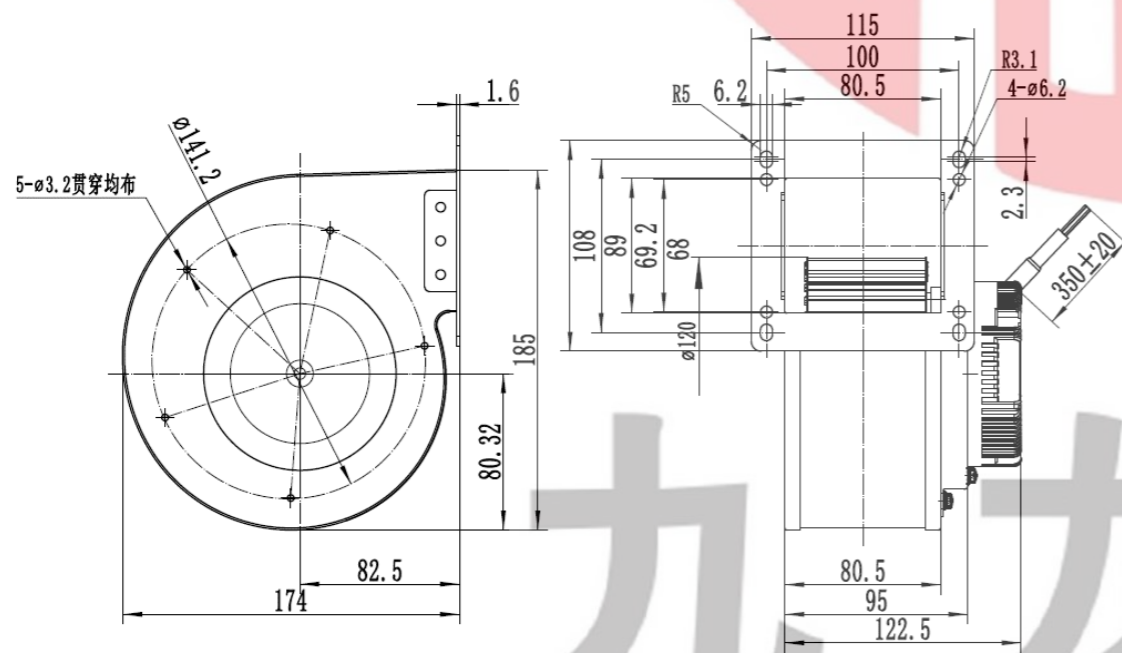
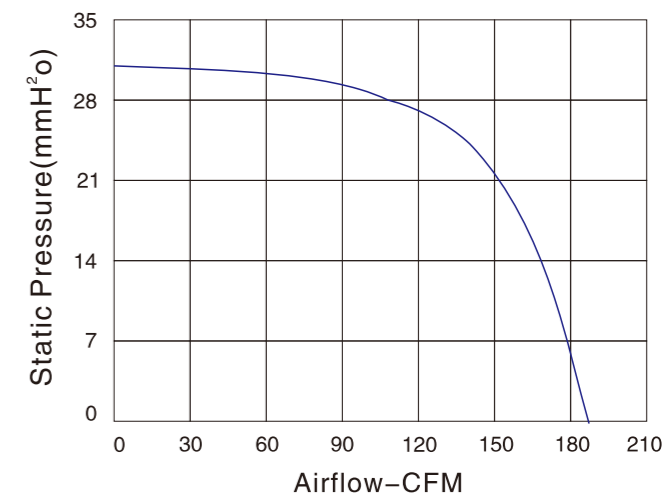

AC Axial Fan  
AC轴流风机

AC All-Metal Axial Fan  
AC全金属轴流风扇

DC Axial Fan  
DC轴流风机

DC Centrifugal Fan  
DC离心风机

EC Axial Fan  
EC轴流风机

EC Centrifugal Fan  
EC离心风机

AC Centrifugal Fan  
AC离心风机

Fan Accessories  
风机配件

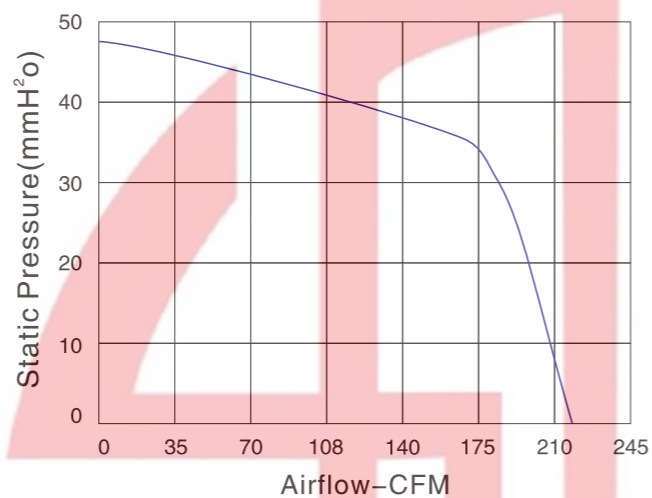

尺寸 Size: Ø133mmX74mm  
风量 Airflow: 224CFM  
噪音 Noise: 58.2dB(A)  
风叶 Impeller Material: Metal  
工作方式 Operation mode: S1  
温度范围 Operating Temperature: -10°C~+65°C  
防护等级 Type of protection: IP44  
绝缘等级 Insulation class: "B"

产品型号 Model	电压 Voltage VDC	电流 Current A	功率 Power W	转速 Speed RPM	风量 Air Flow CFM	静压 Static Pressure mmH <sub>2</sub> O	噪音 Noise dB(A)
YDD133BGD3-A01-W	310	0.26	82	2200	224	48	58.2

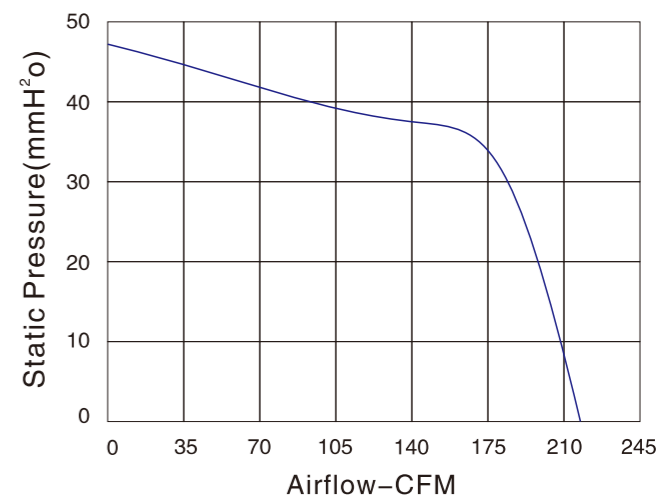
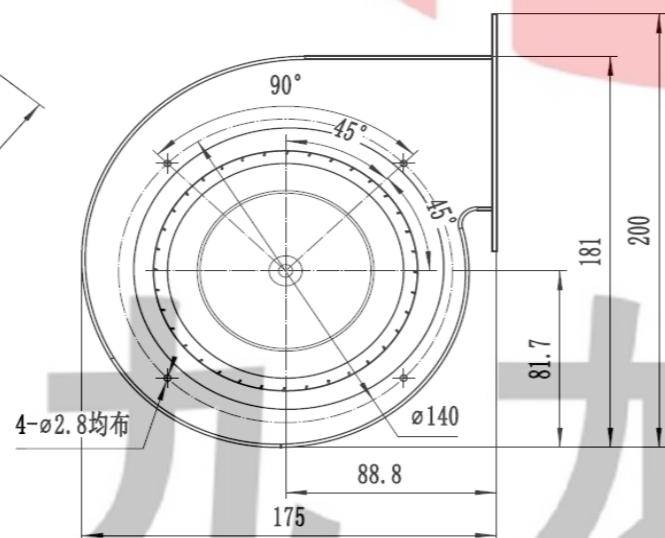
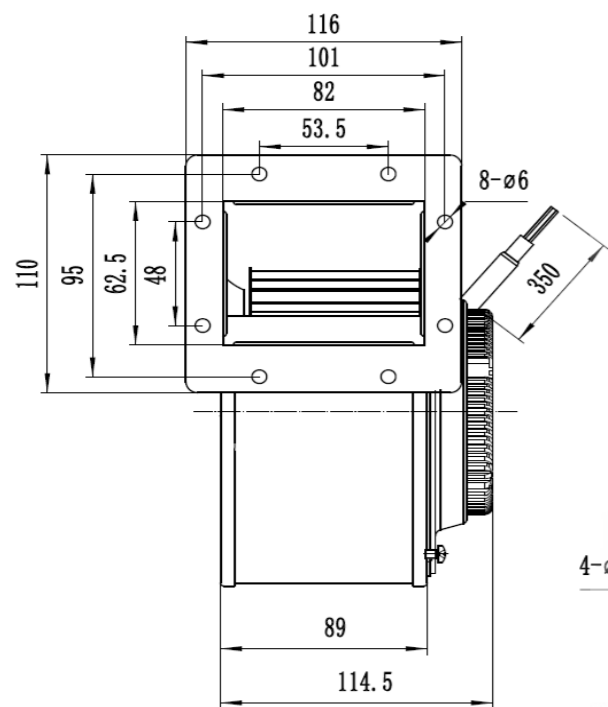

尺寸 Size: Ø133mmX74mm  
风量 Airflow: 224CFM  
噪音 Noise: 58.2dB(A)  
风叶 Impeller Material: Metal  
工作方式 Operation mode: S1  
温度范围 Operating Temperature: -10°C~+65°C  
防护等级 Type of protection: IP44  
绝缘等级 Insulation class: "B"

产品型号 Model	电压 Voltage VDC	电流 Current A	功率 Power W	转速 Speed RPM	风量 Air Flow CFM	静压 Static Pressure mmH <sub>2</sub> O	噪音 Noise dB(A)
YDD133CGD3-A01-W	310	0.26	82	2200	224	48	58.2

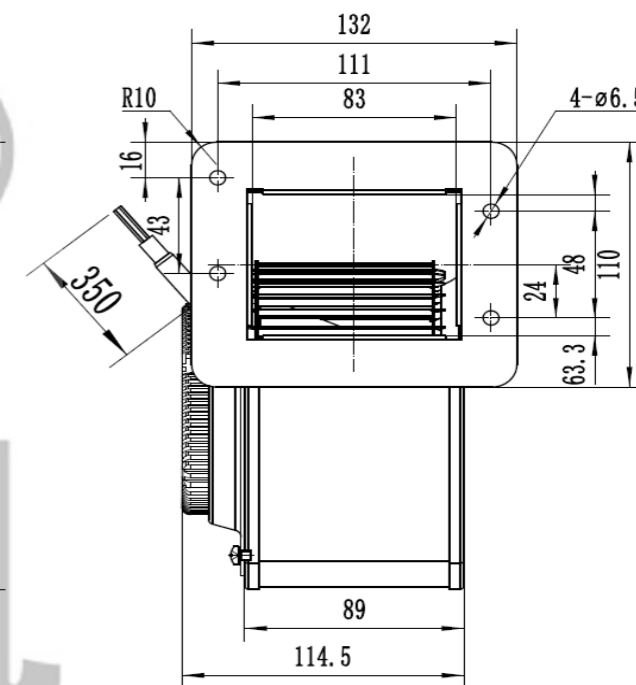
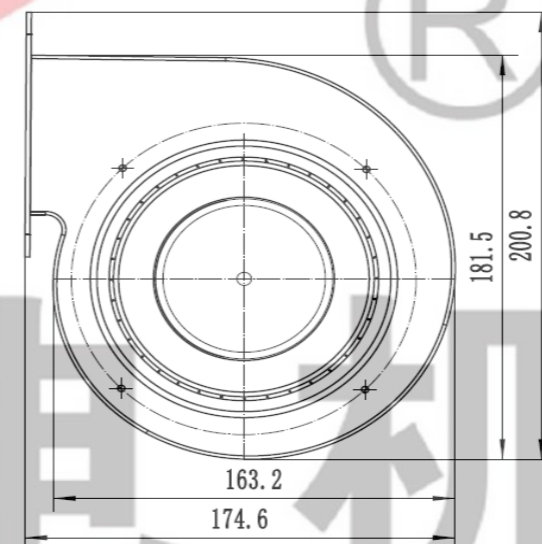

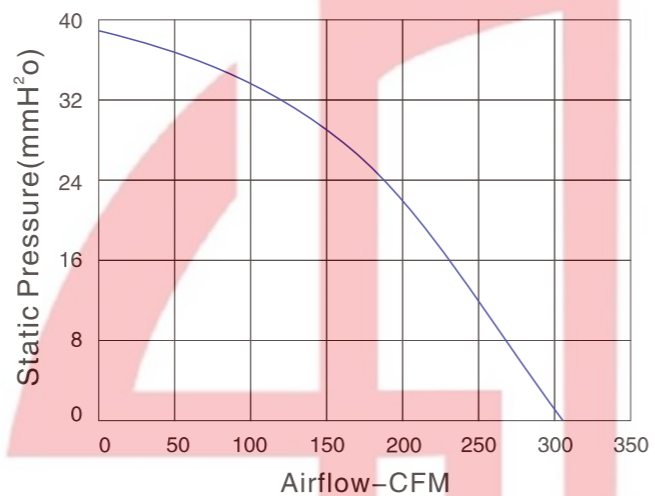

尺寸 Size: Ø140mmX62mm  
风量 Airflow: 306CFM  
噪音 Noise: 64dB(A)  
风叶 Impeller Material: PA66  
工作方式 Operation mode: S1  
温度范围 Operating Temperature: -10°C~+65°C  
防护等级 Type of protection: IP44  
绝缘等级 Insulation class: "B"

产品型号 Model	电压 Voltage VDC	电流 Current A	功率 Power W	转速 Speed RPM	风量 Air Flow CFM	静压 Static Pressure mmH <sub>2</sub> O	噪音 Noise dB(A)
YDD140BGD3-A01-W	310	0.68	108	2000	306	39.3	64

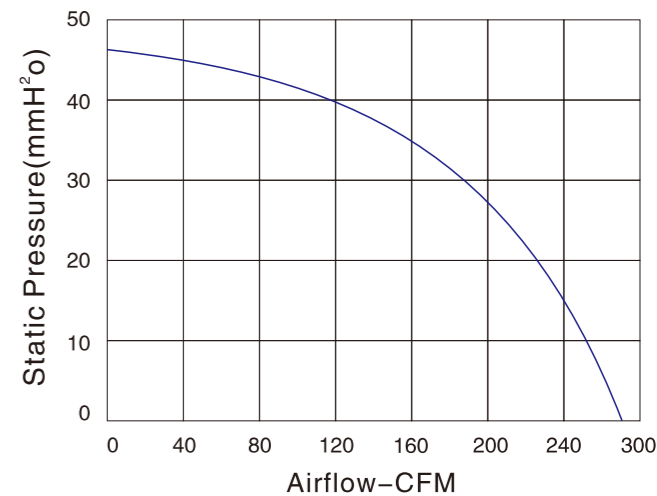
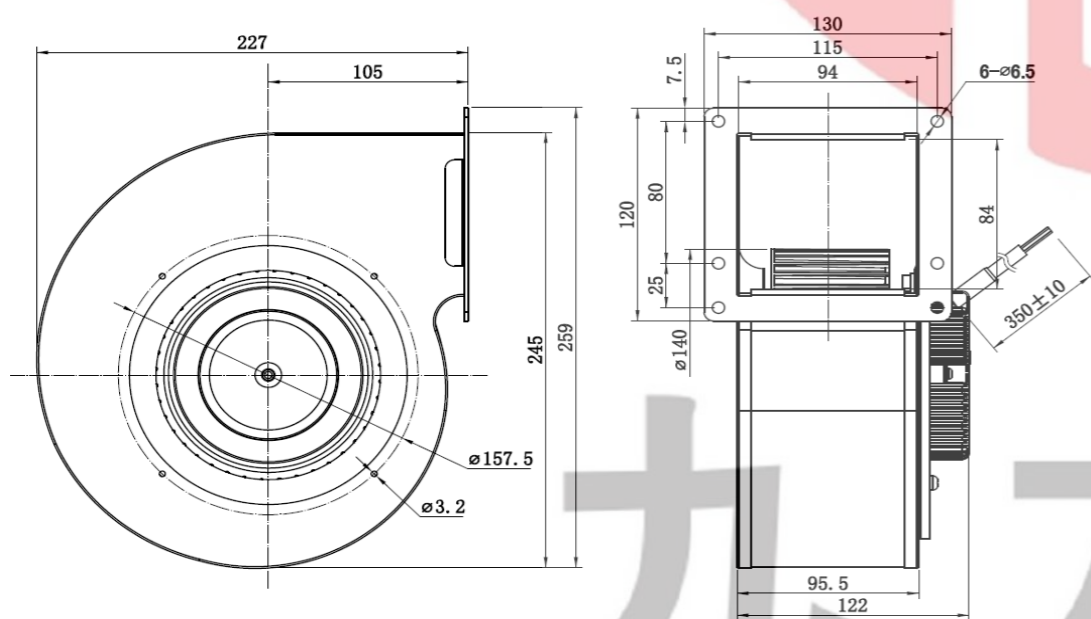

尺寸 Size: Ø150mmX72mm  
风量 Airflow: 275CFM  
噪音 Noise: 68.1dB(A)  
风叶 Impeller Material: Metal  
工作方式 Operation mode: S1  
温度范围 Operating Temperature: -10°C~+65°C  
防护等级 Type of protection: IP44  
绝缘等级 Insulation class: "B"

产品型号 Model	电压 Voltage VDC	电流 Current A	功率 Power W	转速 Speed RPM	风量 Air Flow CFM	静压 Static Pressure mmH <sub>2</sub> O	噪音 Noise dB(A)
YDD150AGD3-A01-W	310	0.4	120	2200	275	47.1	68.1

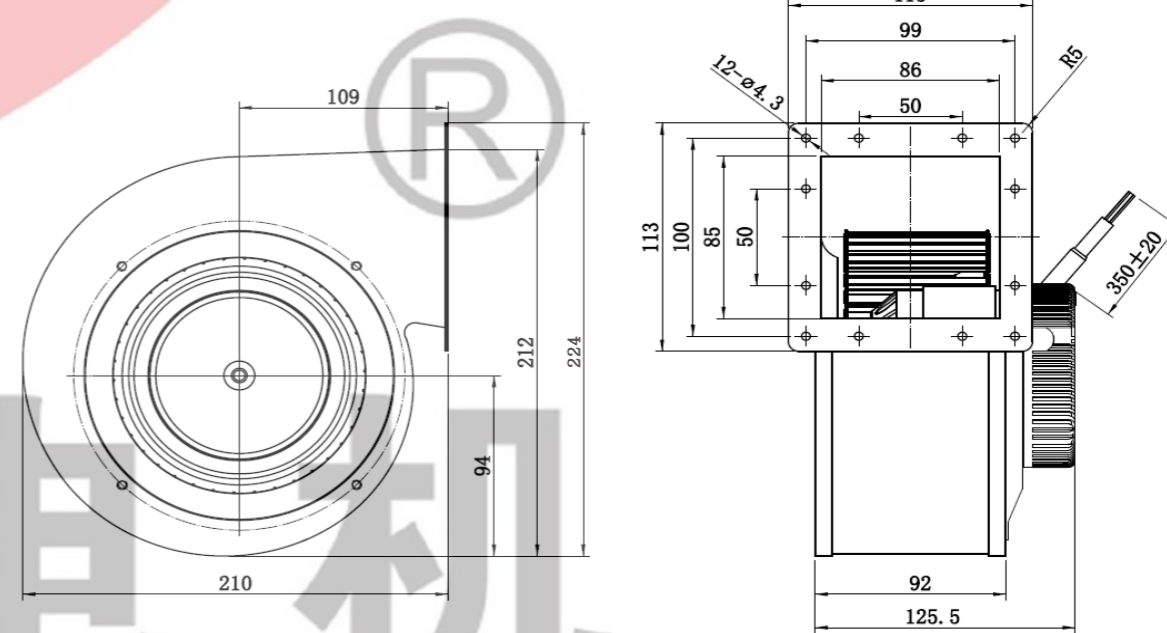

九 龙 电 机

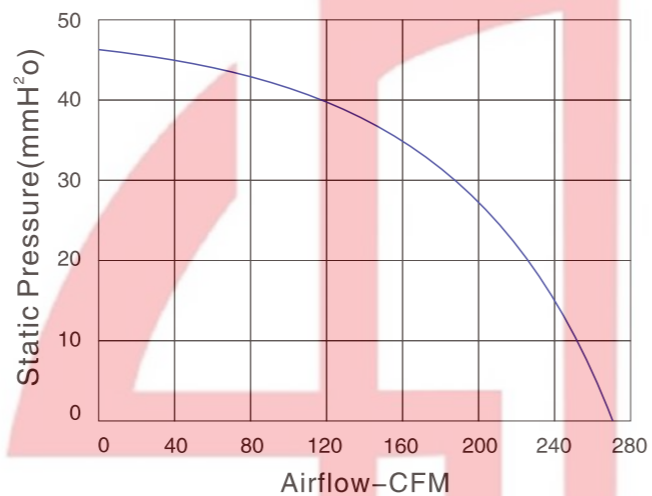

尺寸 Size: Ø150mmX72mm  
风量 Airflow: 275CFM  
噪音 Noise: 68.1dB(A)  
风叶 Impeller Material: Metal  
工作方式 Operation mode: S1  
温度范围 Operating Temperature: -10°C~+65°C  
防护等级 Type of protection: IP44  
绝缘等级 Insulation class: "B"

产品型号 Model	电压 Voltage VDC	电流 Current A	功率 Power W	转速 Speed RPM	风量 Air Flow CFM	静压 Static Pressure mmH <sub>2</sub> O	噪音 Noise dB(A)
YDD150BGD3-A01-W	310	0.4	120	2200	275	47.1	68.1

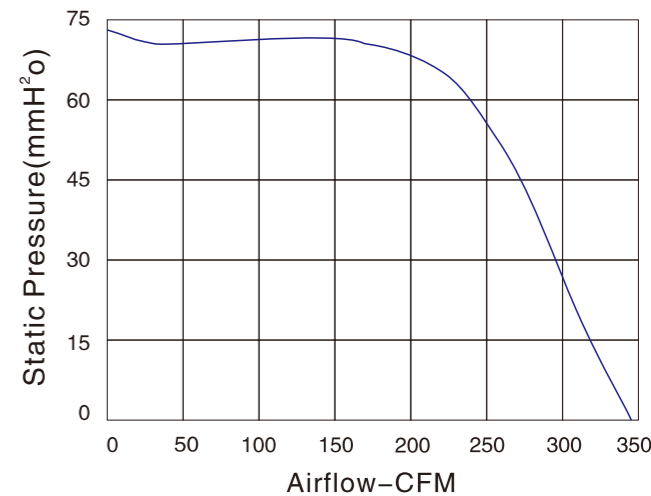
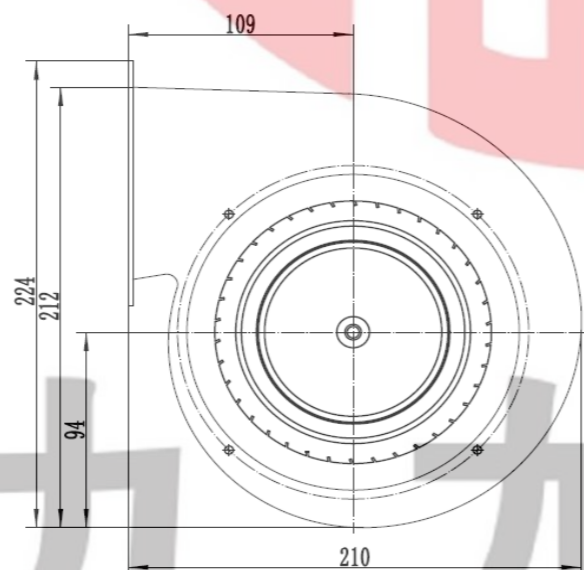
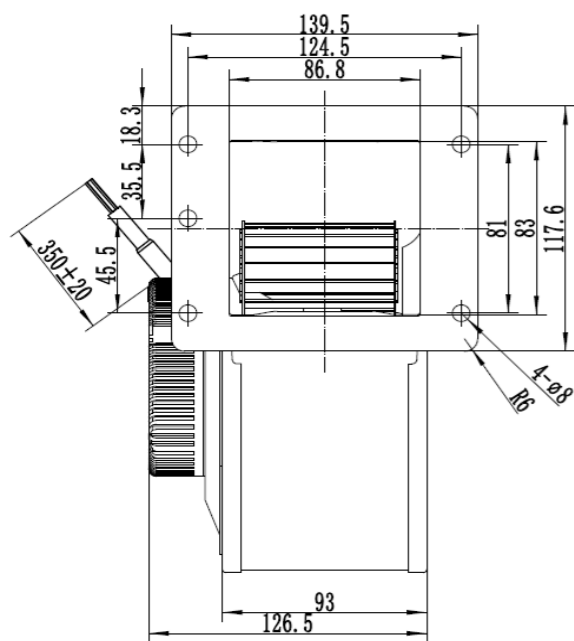

尺寸 Size: Ø160mmX72mm  
风量 Airflow: 348.7CFM  
噪音 Noise: 63.5dB(A)  
风叶 Impeller Material: Metal  
工作方式 Operation mode: S1  
温度范围 Operating Temperature: -10°C~+65°C  
防护等级 Type of protection: IP44  
绝缘等级 Insulation class: "B"

产品型号 Model	电压 Voltage VDC	电流 Current A	功率 Power W	转速 Speed RPM	风量 Air Flow CFM	静压 Static Pressure mmH <sub>2</sub> O	噪音 Noise dB(A)
YDD160AGD3-A01-W	310	0.42	120	1950	348.7	59.5	63.5

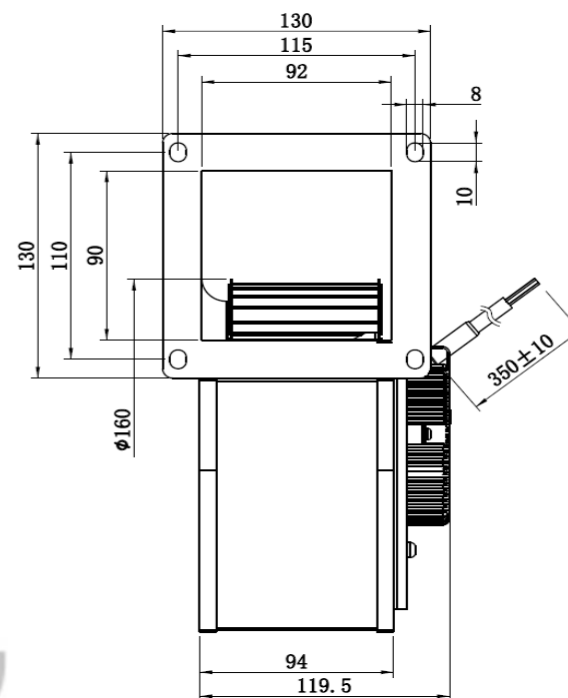
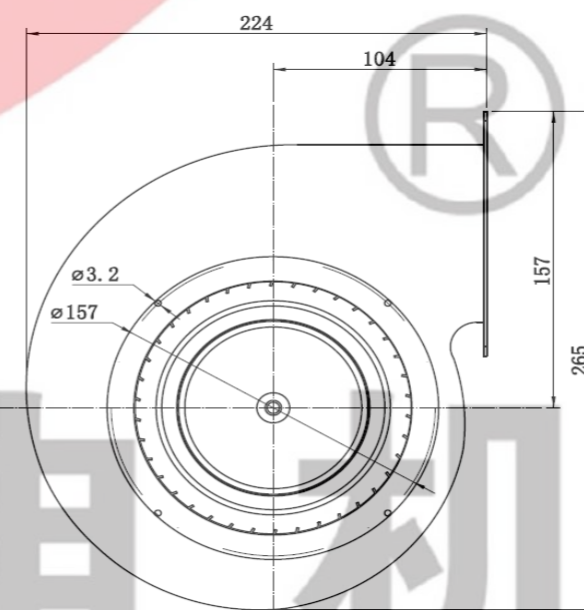



JIULONG MOTOR  
AC/DC FANS COOLING FANS



UL  
E248719



本样机仅做选型参考，具体以实物为准。  
This sample book is for reference only. Please refer to the specification for details.  
如需特殊电压也可特别定制提供。本公司保留技术知识产权。  
Special voltage may be provided flexibly according to the enquiry. All technical modification rights reserved.

Http://www.xtgygs.cn

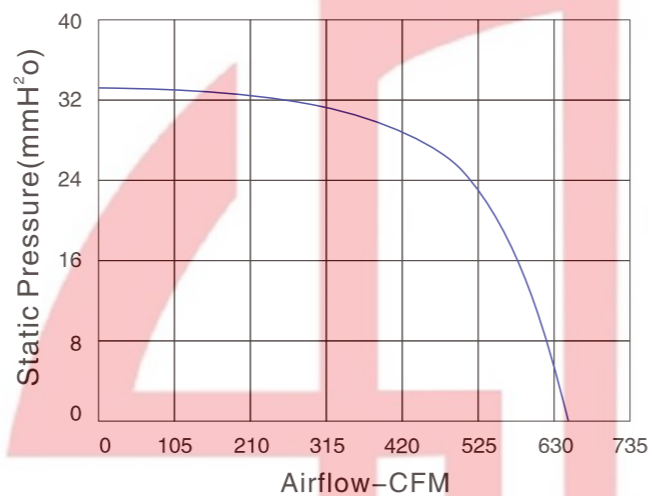

尺寸 Size: Ø180mmX90mm  
风量 Airflow: 645.2CFM  
噪音 Noise: 67.8dB(A)  
风叶 Impeller Material: Metal  
工作方式 Operation mode: S1  
温度范围 Operating Temperature: -10°C~+65°C  
防护等级 Type of protection: IP44  
绝缘等级 Insulation class: "B"

产品型号 Model	电压 Voltage VDC	电流 Current A	功率 Power W	转速 Speed RPM	风量 Air Flow CFM	静压 Static Pressure mmH <sub>2</sub> O	噪音 Noise dB(A)
YDD180AHD3-A01-W	310	0.62	190	1650	645.2	33	67.8

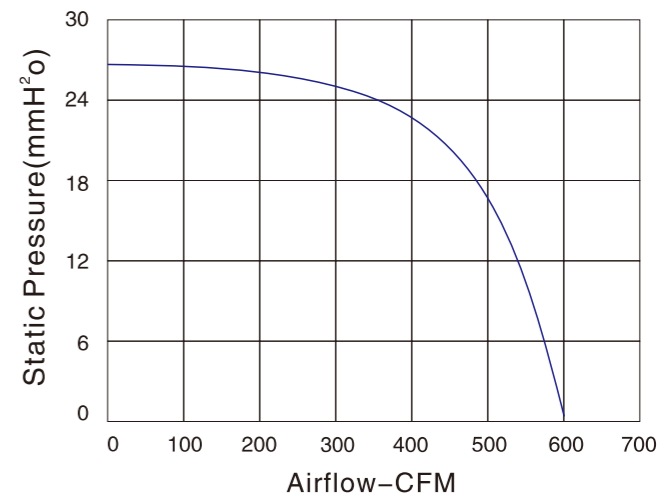

尺寸 Size: Ø200mmX54mm  
风量 Airflow: 589CFM  
噪音 Noise: 58dB(A)  
风叶 Impeller Material: Metal  
工作方式 Operation mode: S1  
温度范围 Operating Temperature: -10°C~+65°C  
防护等级 Type of protection: IP44  
绝缘等级 Insulation class: "B"

产品型号 Model	电压 Voltage VDC	电流 Current A	功率 Power W	转速 Speed RPM	风量 Air Flow CFM	静压 Static Pressure mmH <sub>2</sub> O	噪音 Noise dB(A)
YDD200AHD3-A01-W	310	0.39	120	1300	589	27	58

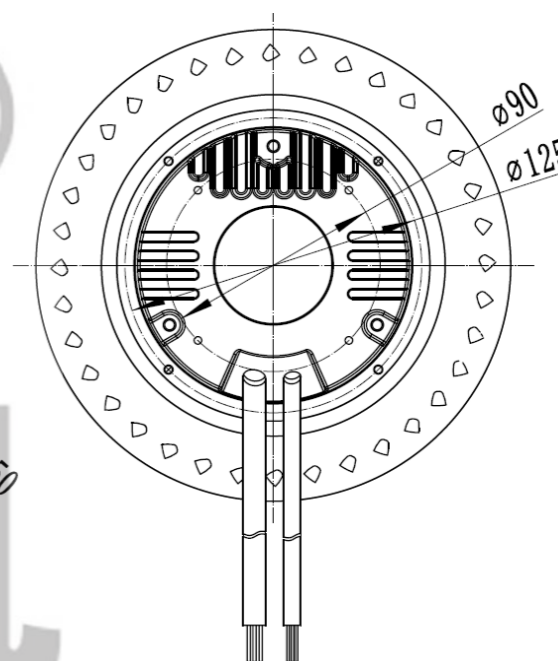
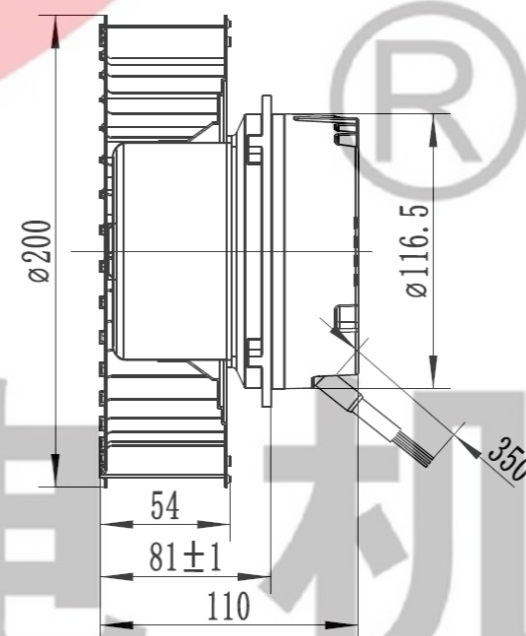
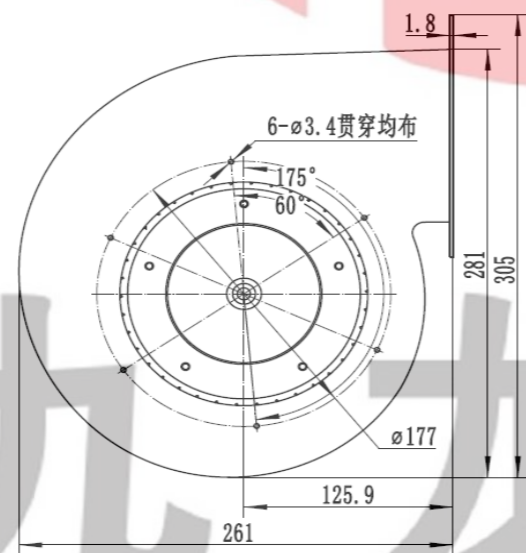
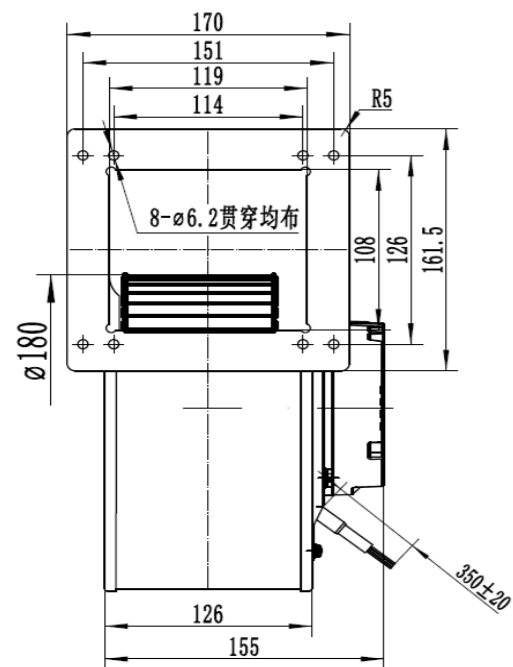

AC Axial Fan  
AC轴流风机

AC All-Metal Axial Fan  
AC全金属轴流风扇

DC Axial Fan  
DC轴流风机

DC Centrifugal Fan  
DC离心风机

EC Axial Fan  
EC轴流风机

EC Centrifugal Fan  
EC离心风机

AC Centrifugal Fan  
AC离心风机

Fan Accessories  
风机配件



JIULONG MOTOR  
AC/DC FANS COOLING FANS



本样图仅供参考，具体以实物为准。  
This sample book is for reference only. Please refer to the specification for details.  
如需特殊电压也可特别定制提供。本公司保留技术知识产权。  
Special voltage may be provided flexibly according to the enquiry. All technical modification rights reserved.

Http://www.xtgygs.cn

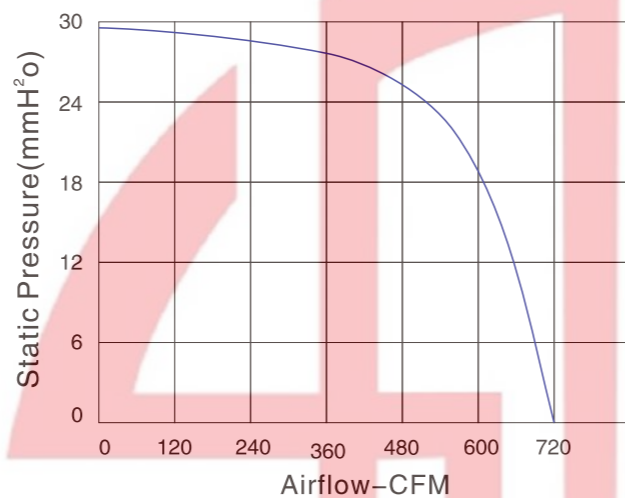

尺寸 Size: Ø200mmX81mm  
风量 Airflow: 719CFM  
噪音 Noise: 53dB(A)  
风叶 Impeller Material: Metal  
工作方式 Operation mode: S1  
温度范围 Operating Temperature: -10°C~+65°C  
防护等级 Type of protection: IP44  
绝缘等级 Insulation class: "B"

产品型号 Model	电压 Voltage VDC	电流 Current A	功率 Power W	转速 Speed RPM	风量 Air Flow CFM	静压 Static Pressure mmH <sub>2</sub> O	噪音 Noise dB(A)
YDD200BHA2-A01-W	310	0.47	145	1400	719	29.5	53

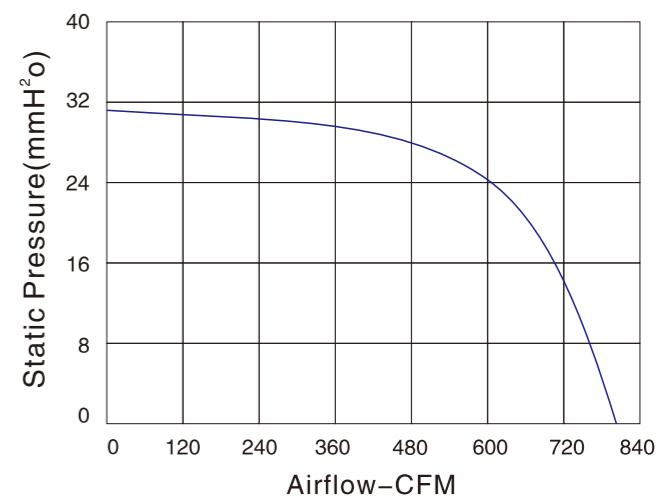
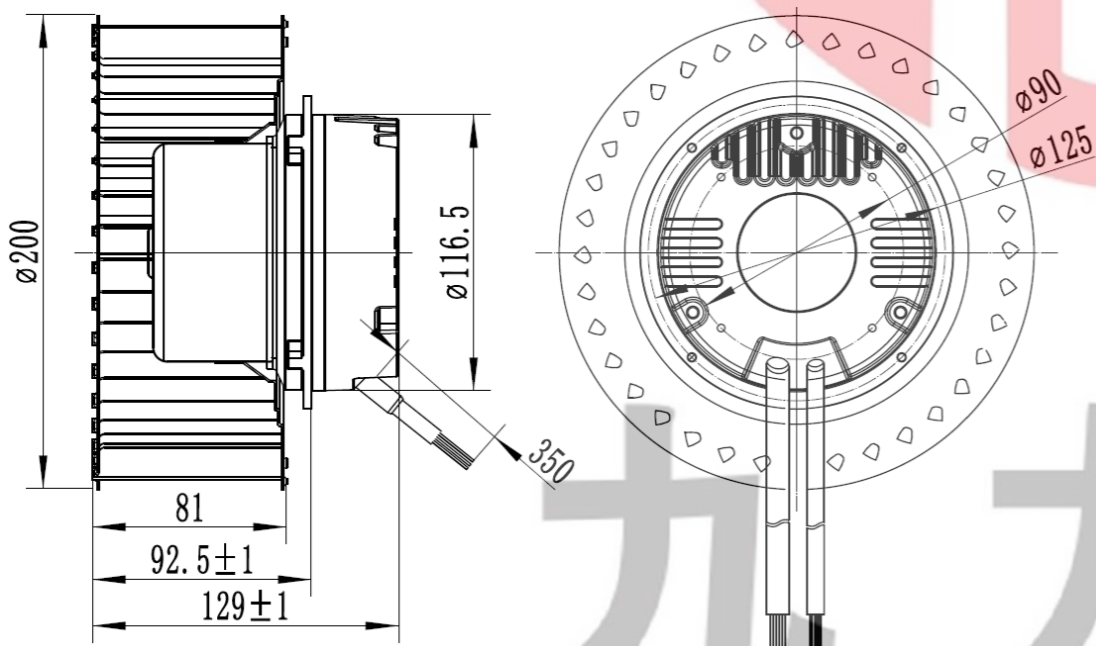

尺寸 Size: Ø200mmX81mm  
风量 Airflow: 795CFM  
噪音 Noise: 53dB(A)  
风叶 Impeller Material: Metal  
工作方式 Operation mode: S1  
温度范围 Operating Temperature: -10°C~+65°C  
防护等级 Type of protection: IP44  
绝缘等级 Insulation class: "B"

产品型号 Model	电压 Voltage VDC	电流 Current A	功率 Power W	转速 Speed RPM	风量 Air Flow CFM	静压 Static Pressure mmH <sub>2</sub> O	噪音 Noise dB(A)
YDD200CHD3-A01-W	310	0.58	180	1350	795	30.6	53

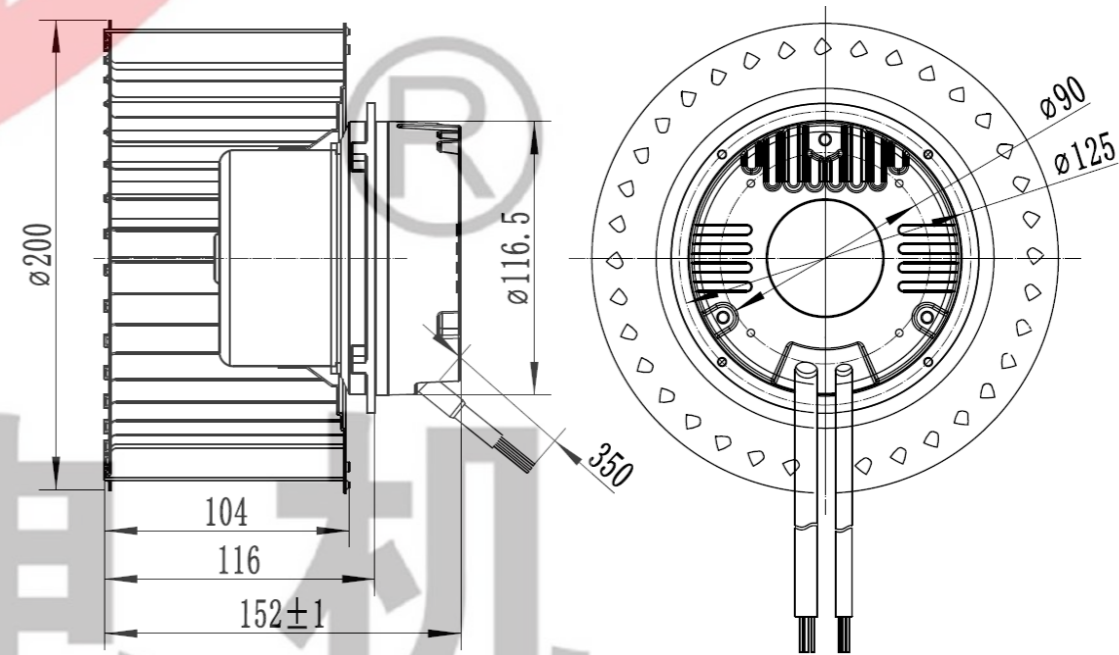

九 龙 电 机

AC Axial Fan  
AC轴流风机

AC All-Metal Axial Fan  
AC全金属轴流风扇

DC Axial Fan  
DC轴流风机

DC Centrifugal Fan  
DC离心风机

EC Axial Fan  
EC轴流风机

EC Centrifugal Fan  
EC离心风机

AC Centrifugal Fan  
AC离心风机

Fan Accessories  
风机配件

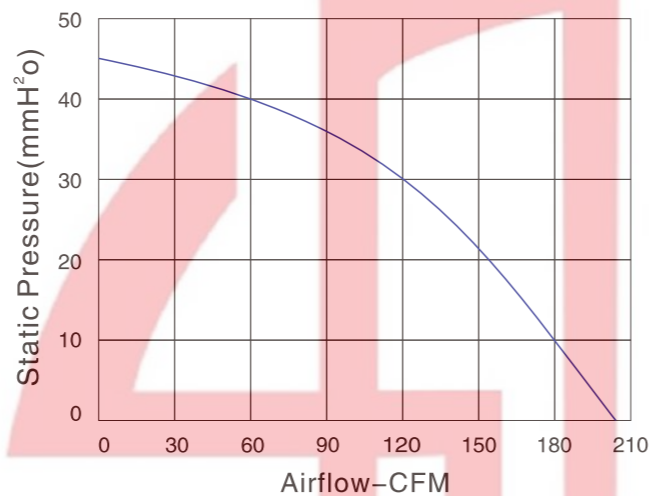

尺寸 Size: Ø133mmX62mm  
风量 Airflow: 202CFM  
噪音 Noise: 63dB(A)  
风叶 Impeller Material: PA66  
工作方式 Operation mode: S1  
温度范围 Operating Temperature: -10°C~+65°C  
防护等级 Type of protection: IP44  
绝缘等级 Insulation class: "B"

产品型号 Model	电压 Voltage VDC	电流 Current A	功率 Power W	转速 Speed RPM	风量 Air Flow CFM	静压 Static Pressure mmH <sub>2</sub> O	噪音 Noise dB(A)
YDH133AGD3-G01	310	0.15	48	4500	202	45	63

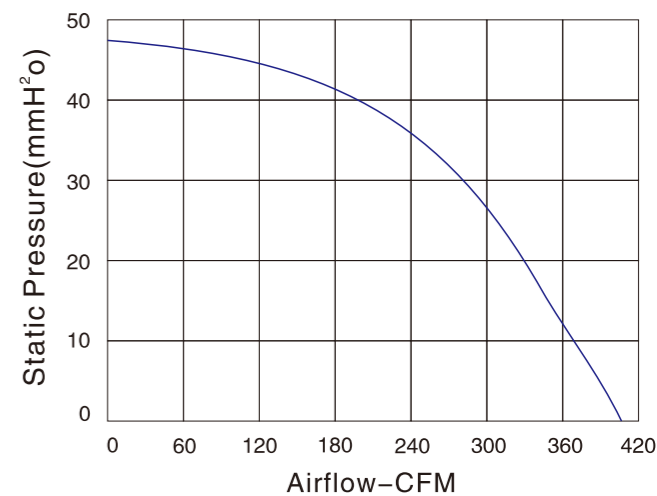
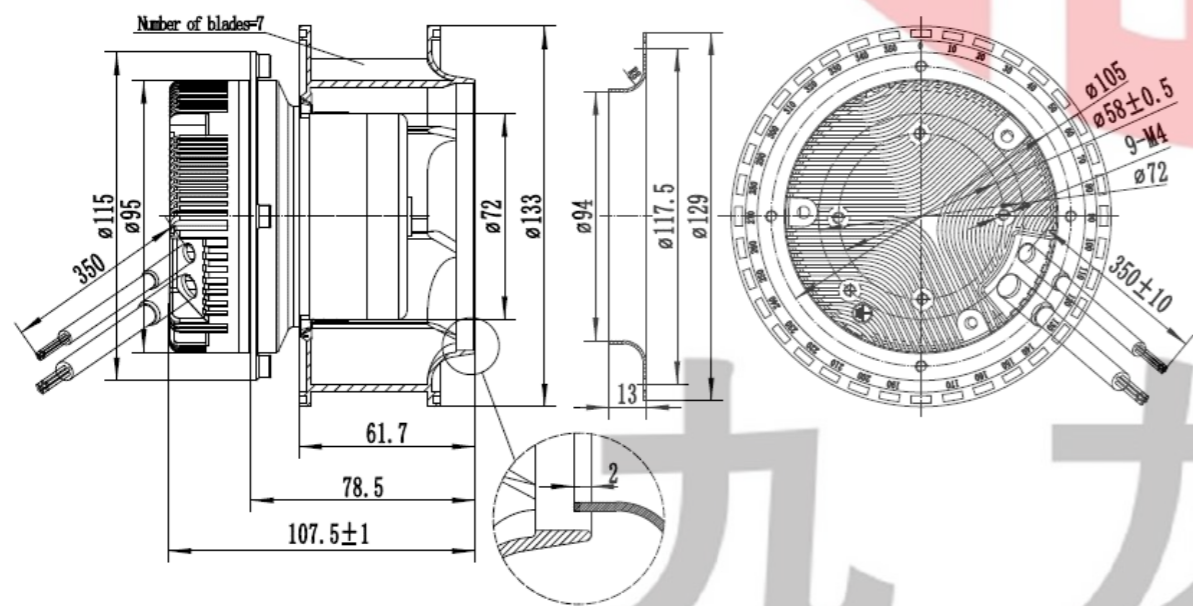

尺寸 Size: Ø175mmX65mm  
风量 Airflow: 400.5CFM  
噪音 Noise: 68dB(A)  
风叶 Impeller Material: PA66  
工作方式 Operation mode: S1  
温度范围 Operating Temperature: -10°C~+65°C  
防护等级 Type of protection: IP44  
绝缘等级 Insulation class: "B"

产品型号 Model	电压 Voltage VDC	电流 Current A	功率 Power W	转速 Speed RPM	风量 Air Flow CFM	静压 Static Pressure mmH <sub>2</sub> O	噪音 Noise dB(A)
YDH175AGD3-G01	310	0.14	43	3500	400.5	48.3	68

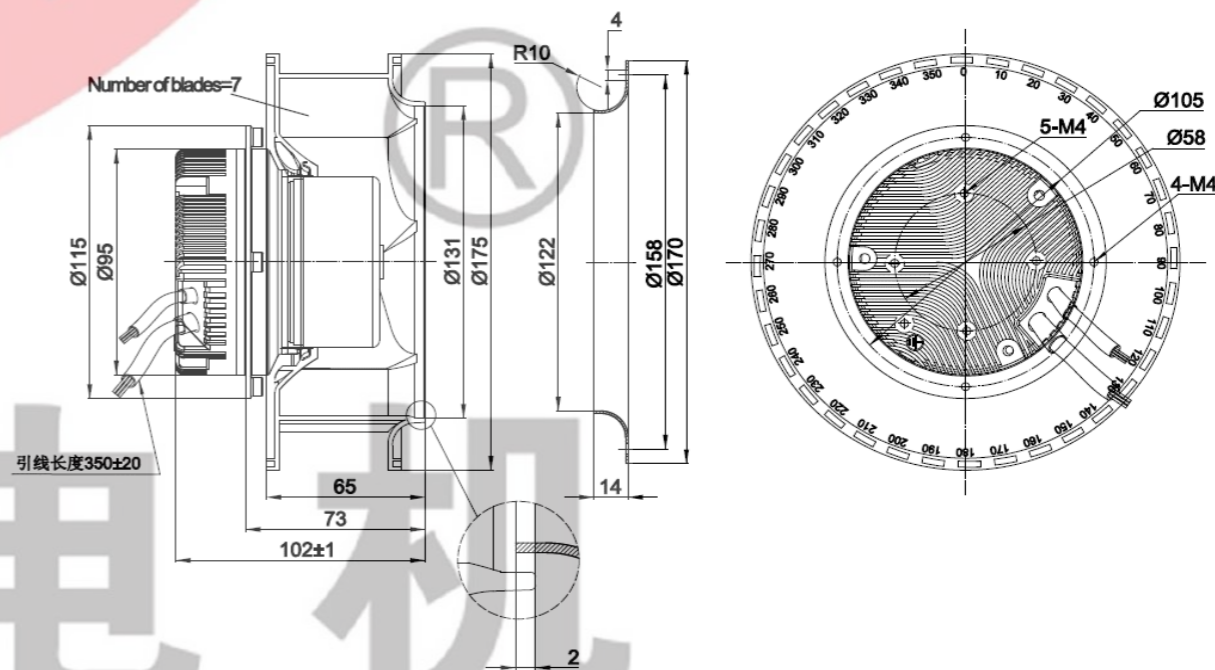



JULONG MOTOR  
AC/DC FANS COOLING FANS



本样图仅供参考，具体以实物为准。  
This sample book is for reference only. Please refer to the specification for details.  
如需特殊电压也可特别定制提供。本公司保留技术知识产权。  
Special voltage may be provided flexibly according to the enquiry. All technical modification rights reserved.

Http://www.xtgygs.cn

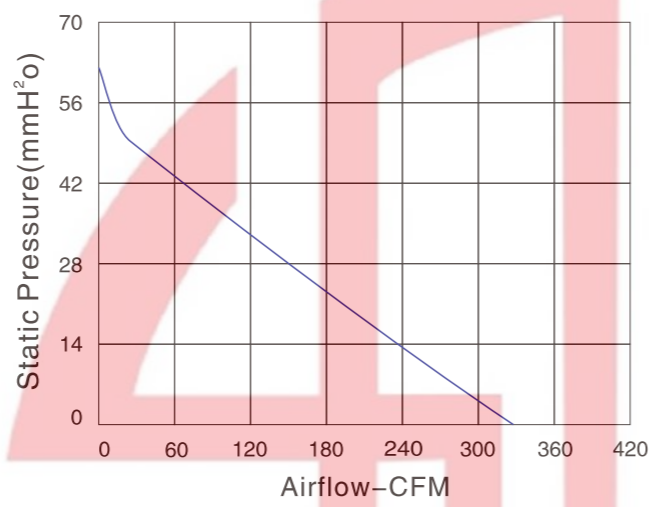

尺寸 Size: Ø180mmX69mm  
风量 Airflow: 340CFM  
噪音 Noise: 61dB(A)  
风叶 Impeller Material: ABS+GF  
工作方式 Operation mode: S1  
温度范围 Operating Temperature: -10°C~+65°C  
防护等级 Type of protection: IP44  
绝缘等级 Insulation class: "B"

产品型号 Model	电压 Voltage VDC	电流 Current A	功率 Power W	转速 Speed RPM	风量 Air Flow CFM	静压 Static Pressure mmH <sub>2</sub> O	噪音 Noise dB(A)
YDH180AGD3-G01	310	0.19	58	2800	340	62.7	61

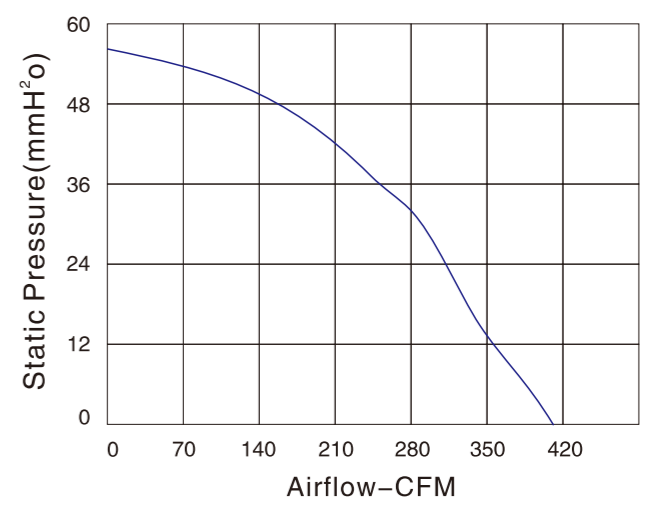
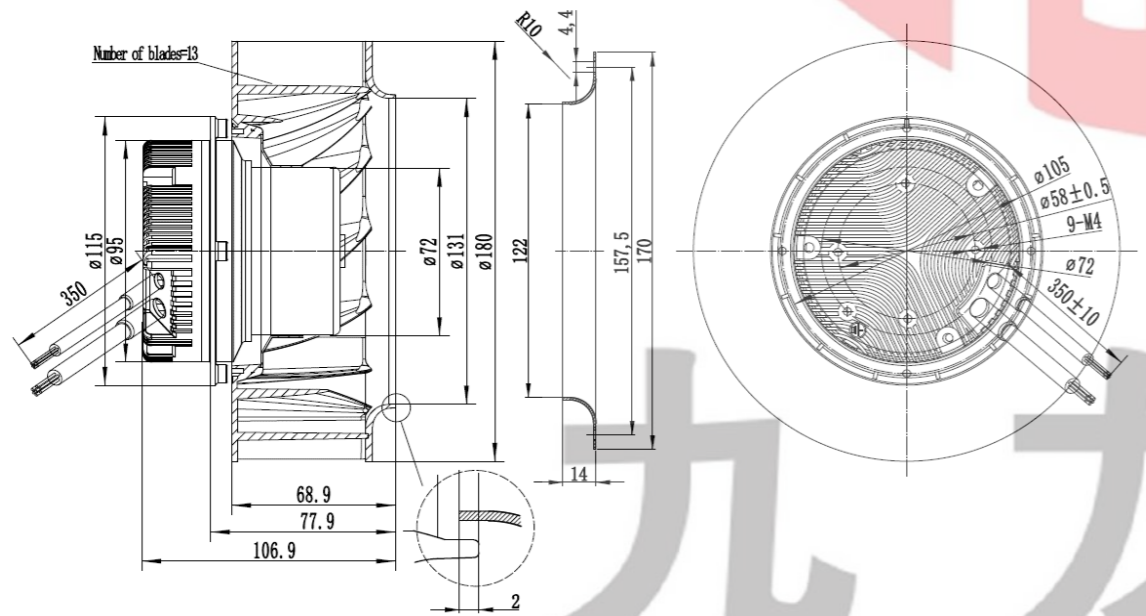

尺寸 Size: Ø190mmX61mm  
风量 Airflow: 414.8CFM  
噪音 Noise: 66.7dB(A)  
风叶 Impeller Material: PA66  
工作方式 Operation mode: S1  
温度范围 Operating Temperature: -10°C~+65°C  
防护等级 Type of protection: IP44  
绝缘等级 Insulation class: "B"

产品型号 Model	电压 Voltage VDC	电流 Current A	功率 Power W	转速 Speed RPM	风量 Air Flow CFM	静压 Static Pressure mmH <sub>2</sub> O	噪音 Noise dB(A)
YDH190BGD3-A01	310	0.27	85	3400	414.8	56.5	66.7

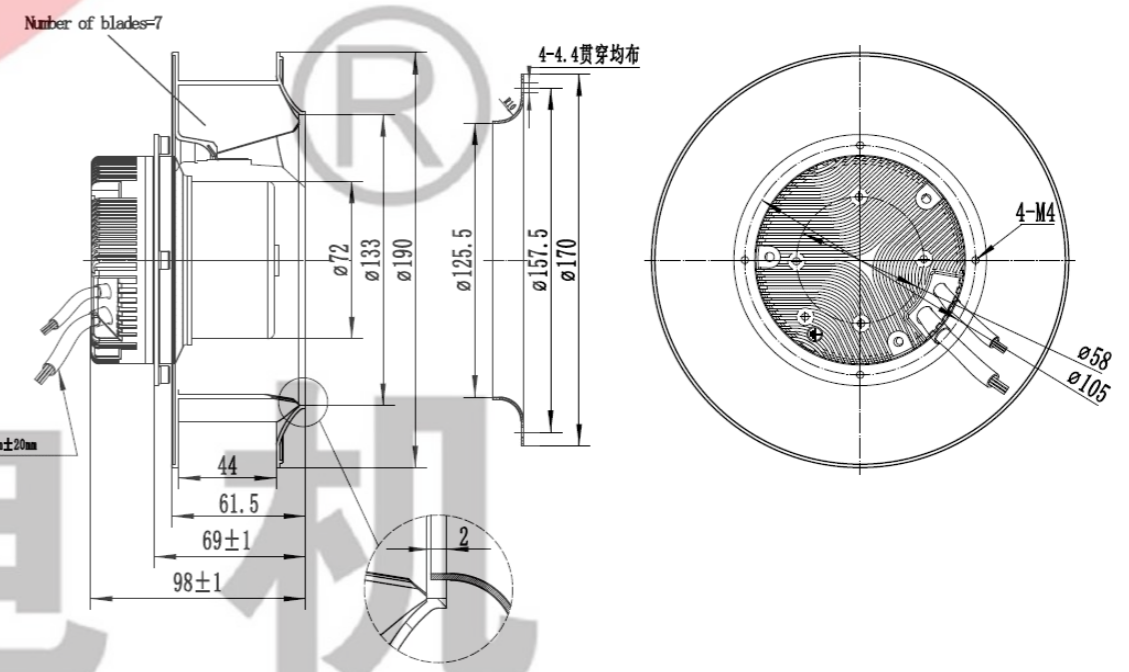

九龙电机

AC Axial Fan  
AC轴流风机

AC All-Metal Axial Fan  
AC全金属轴流风扇

DC Axial Fan  
DC轴流风机

DC Centrifugal Fan  
DC离心风机

EC Axial Fan  
EC轴流风机

EC Centrifugal Fan  
EC离心风机

AC Centrifugal Fan  
AC离心风机

Fan Accessories  
风机配件

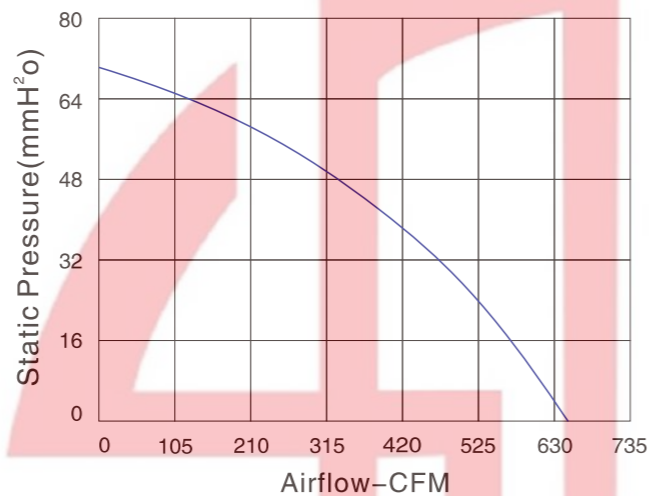

尺寸 Size: Ø220mmX65mm  
风量 Airflow: 645.5CFM  
噪音 Noise: 77.2dB(A)  
风叶 Impeller Material: PA66  
工作方式 Operation mode: S1  
温度范围 Operating Temperature: -10°C~+65°C  
防护等级 Type of protection: IP44  
绝缘等级 Insulation class: "B"

产品型号 Model	电压 Voltage VDC	电流 Current A	功率 Power W	转速 Speed RPM	风量 Air Flow CFM	静压 Static Pressure mmH <sub>2</sub> O	噪音 Noise dB(A)
YDH220AGD3-A01	310	0.36	110	3100	645.5	70	77.2

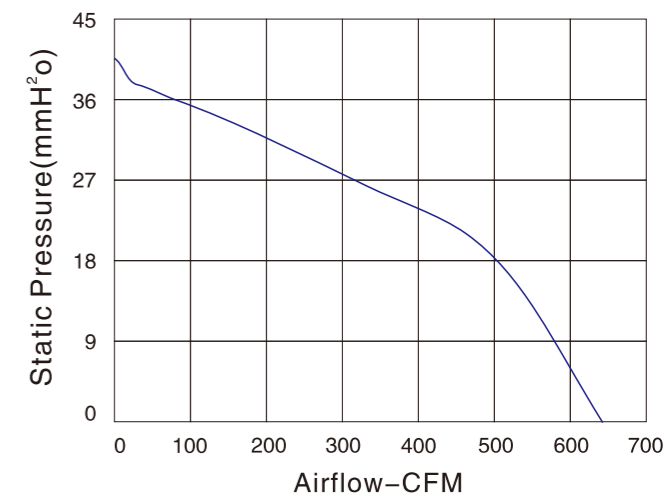

尺寸 Size: Ø220mmX93mm  
风量 Airflow: 597.4CFM  
噪音 Noise: 65.4dB(A)  
风叶 Impeller Material: ABS+GF  
工作方式 Operation mode: S1  
温度范围 Operating Temperature: -10°C~+65°C  
防护等级 Type of protection: IP44  
绝缘等级 Insulation class: "B"

产品型号 Model	电压 Voltage VDC	电流 Current A	功率 Power W	转速 Speed RPM	风量 Air Flow CFM	静压 Static Pressure mmH <sub>2</sub> O	噪音 Noise dB(A)
YDH220BGD3-B01	310	0.32	100	2200	597.4	40.2	65.4

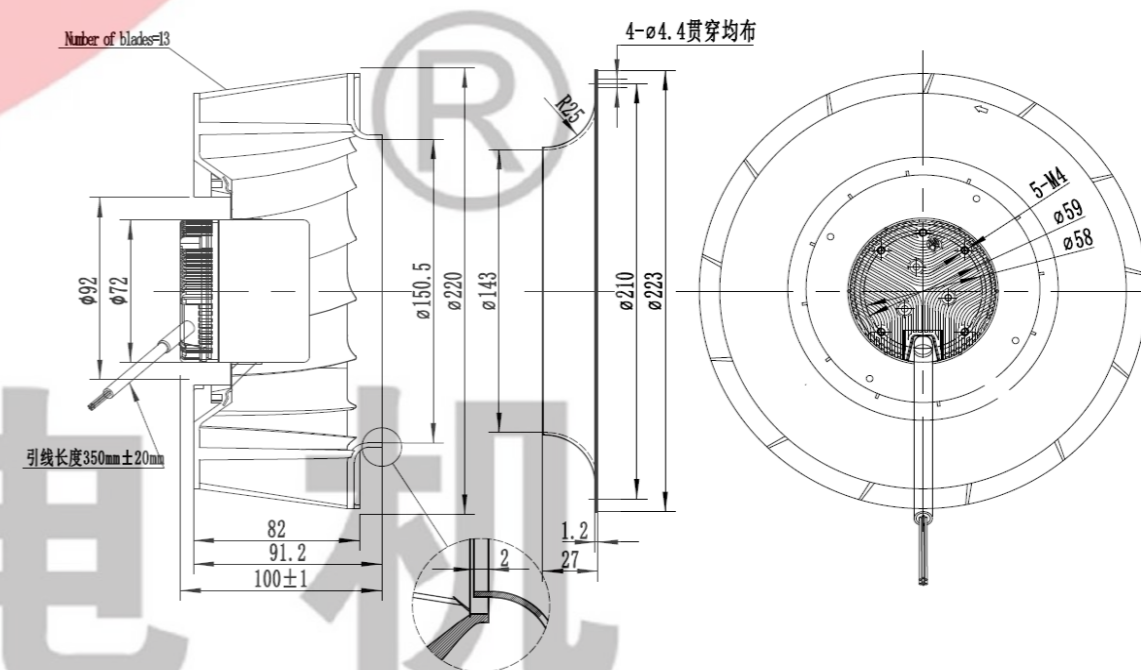
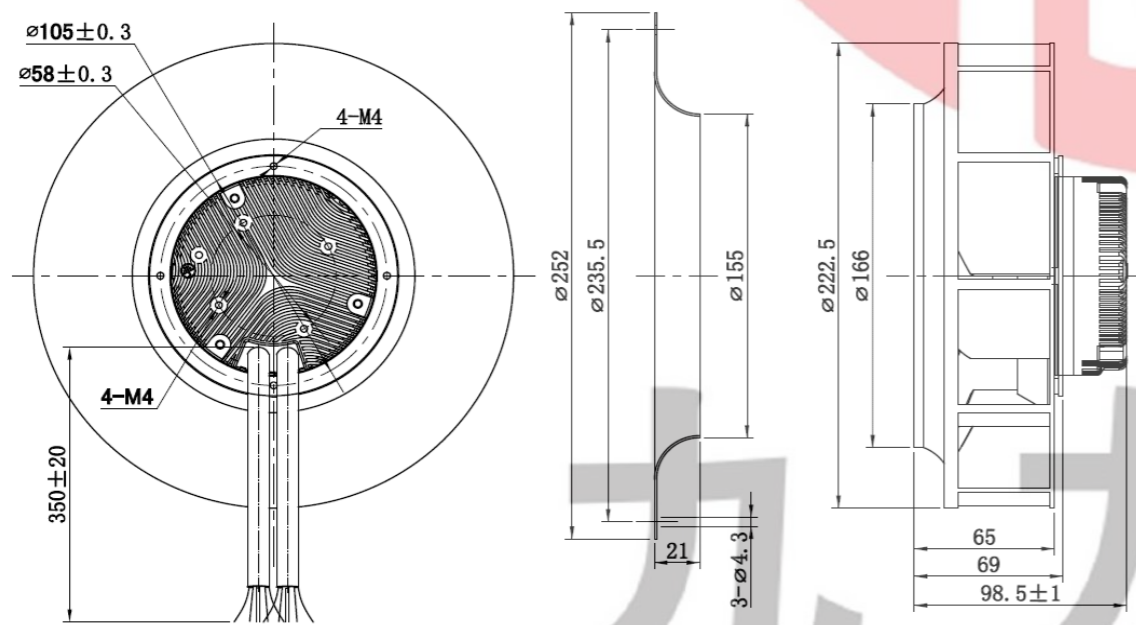



JIULONG MOTOR  
AC/DC FANS COOLING FANS



本样机仅供参考，具体以规格书为准。  
This sample book is for reference only. Please refer to the specification for details.  
如需特殊电压也可根据规格书提供。本公司保留技术知识产权。  
Special voltage may be provided flexibly according to the enquiry. All technical modification rights reserved.

Http://www.xtgygs.cn

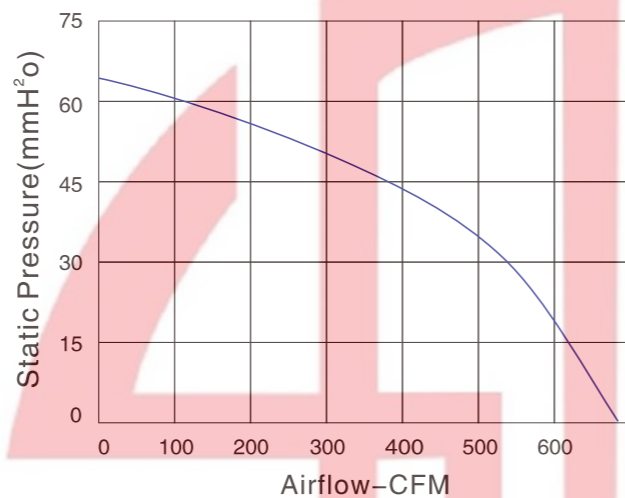

尺寸 Size: Ø225mmX75mm  
风量 Airflow: 683CFM  
噪音 Noise: 73dB(A)  
风叶 Impeller Material: PA66  
工作方式 Operation mode: S1  
温度范围 Operating Temperature: -10°C~+65°C  
防护等级 Type of protection: IP44  
绝缘等级 Insulation class: "B"

产品型号 Model	电压 Voltage VDC	电流 Current A	功率 Power W	转速 Speed RPM	风量 Air Flow CFM	静压 Static Pressure mmH <sub>2</sub> O	噪音 Noise dB(A)
YDH225BGD3-A01	310	0.27	85	3000	683	66.3	73

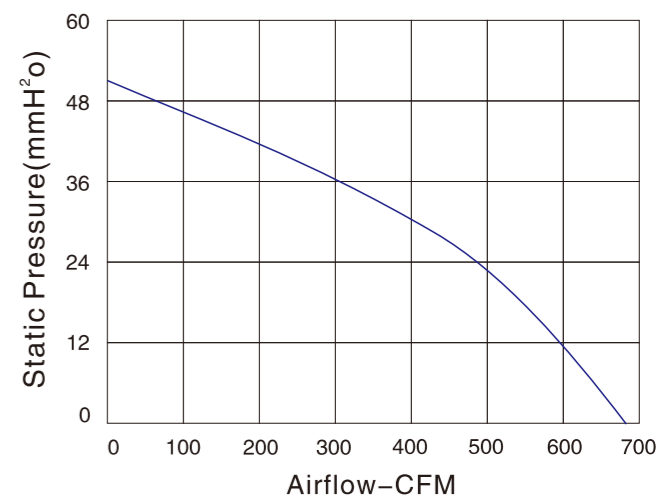
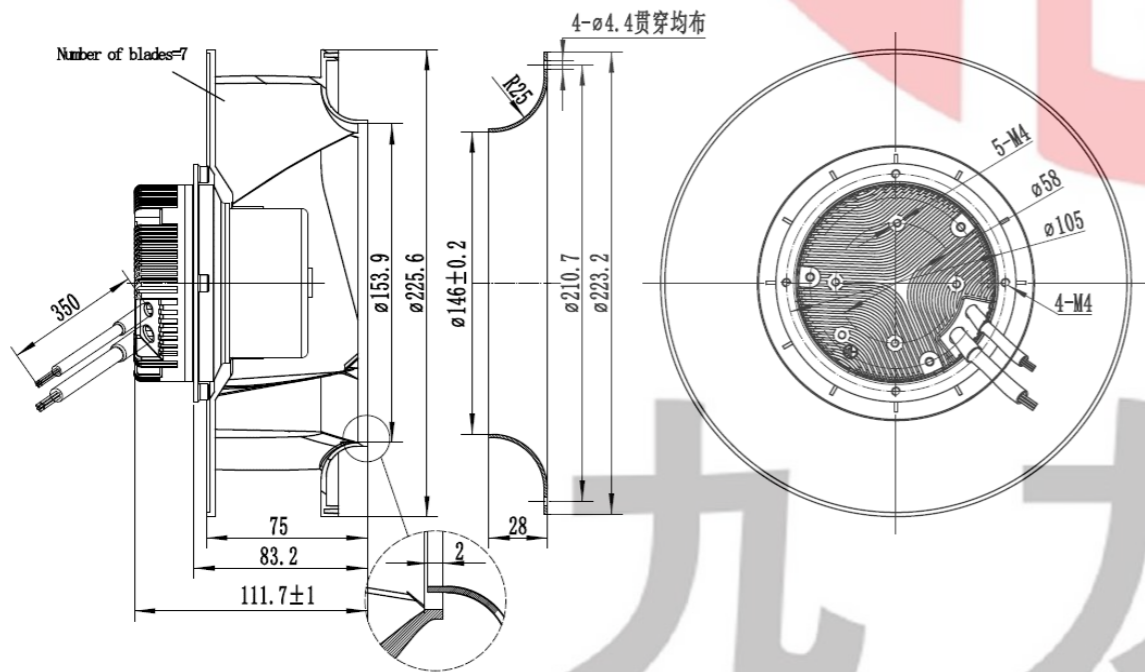

尺寸 Size: Ø225mmX89mm  
风量 Airflow: 678.8CFM  
噪音 Noise: 68.1dB(A)  
风叶 Impeller Material: PA66  
工作方式 Operation mode: S1  
温度范围 Operating Temperature: -10°C~+65°C  
防护等级 Type of protection: IP44  
绝缘等级 Insulation class: "B"

产品型号 Model	电压 Voltage VDC	电流 Current A	功率 Power W	转速 Speed RPM	风量 Air Flow CFM	静压 Static Pressure mmH <sub>2</sub> O	噪音 Noise dB(A)
YDH225CGD3-A01	310	0.55	120	2500	678.8	51.9	68.1

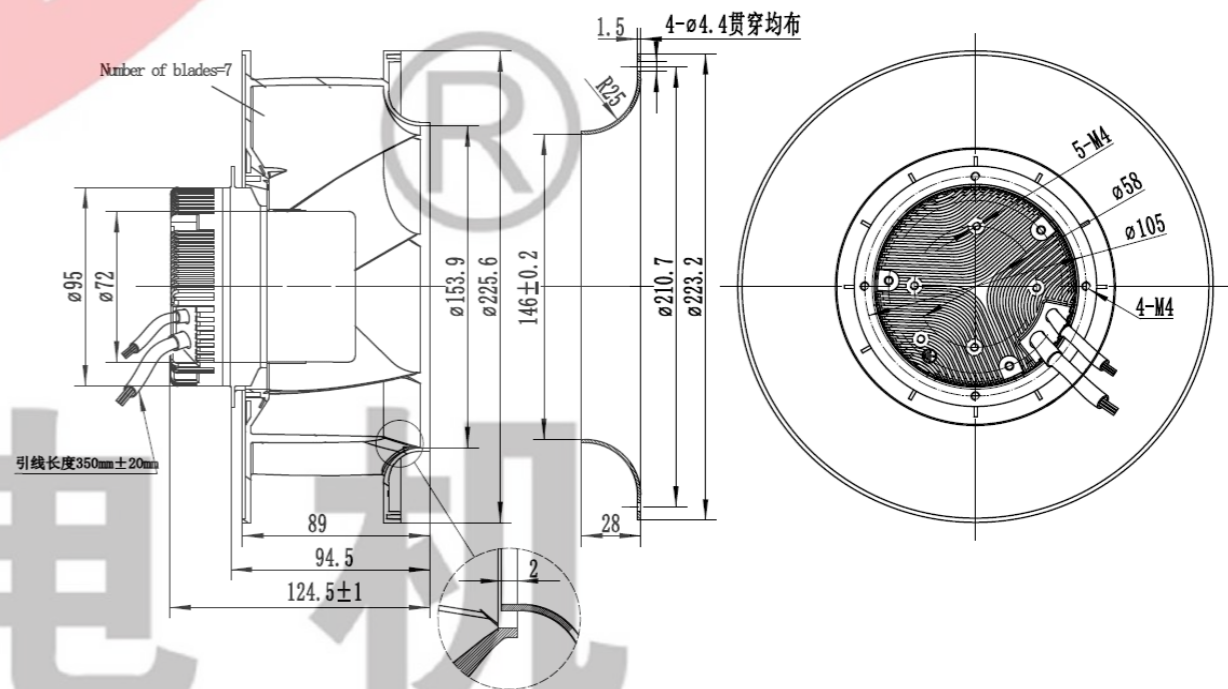

九 龙 电 机

AC Axial Fan  
AC轴流风机

AC All-Metal Axial Fan  
AC全金属轴流风扇

DC Axial Fan  
DC轴流风机

DC Centrifugal Fan  
DC离心风机

EC Axial Fan  
EC轴流风机

EC Centrifugal Fan  
EC离心风机

AC Centrifugal Fan  
AC离心风机

Fan Accessories  
风机配件



JIULONG MOTOR  
AC/DC FANS COOLING FANS



UL  
E248719



本样图仅供参考，具体以实物为准。  
This sample book is for reference only. Please refer to the specification for details.  
如需特殊电压也可根据需求提供，本公司保留技术知识产权。  
Special voltage may be provided flexibly according to the enquiry, although technical modification is reserved.

Http://www.xtgygs.cn

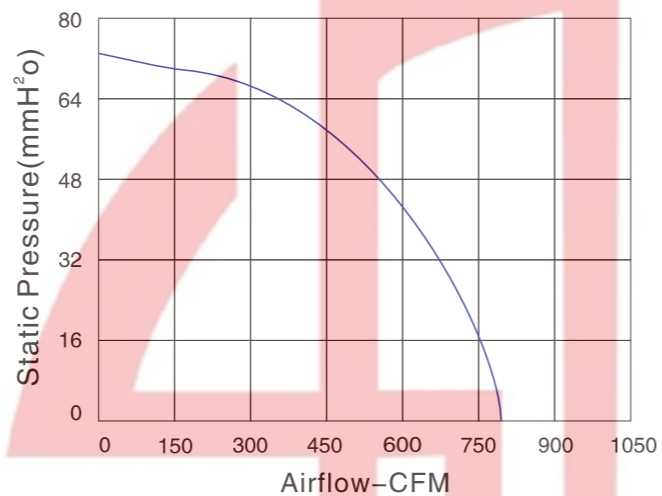

尺寸 Size: Ø225mmX89mm  
风量 Airflow: 814.6CFM  
噪音 Noise: 72.1dB(A)  
风叶 Impeller Material: PA66  
工作方式 Operation mode: S1  
温度范围 Operating Temperature: -10°C~+65°C  
防护等级 Type of protection: IP44  
绝缘等级 Insulation class: "B"

产品型号 Model	电压 Voltage VDC	电流 Current A	功率 Power W	转速 Speed RPM	风量 Air Flow CFM	静压 Static Pressure mmH <sub>2</sub> O	噪音 Noise dB(A)
YDH225CHD3-A01	310	0.45	140	3000	814.6	74.7	72.1

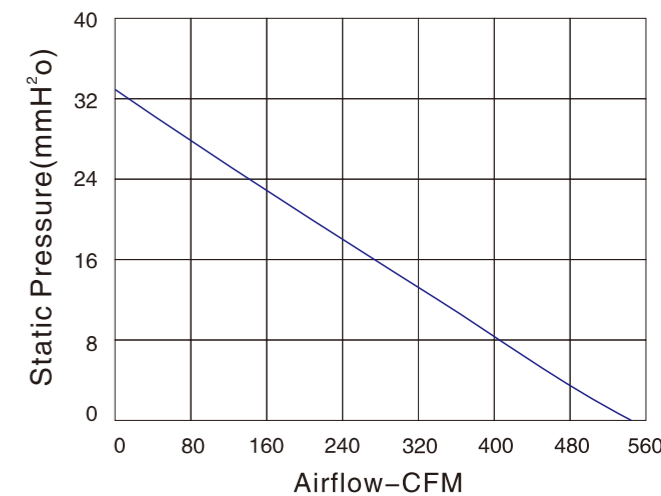

尺寸 Size: Ø225mmX93mm  
风量 Airflow: 543.1CFM  
噪音 Noise: 63dB(A)  
风叶 Impeller Material: ABS+GF  
工作方式 Operation mode: S1  
温度范围 Operating Temperature: -10°C~+65°C  
防护等级 Type of protection: IP44  
绝缘等级 Insulation class: "B"

产品型号 Model	电压 Voltage VDC	电流 Current A	功率 Power W	转速 Speed RPM	风量 Air Flow CFM	静压 Static Pressure mmH <sub>2</sub> O	噪音 Noise dB(A)
YDH225DGD3-A01	310	0.25	80	2000	543.1	33.2	63

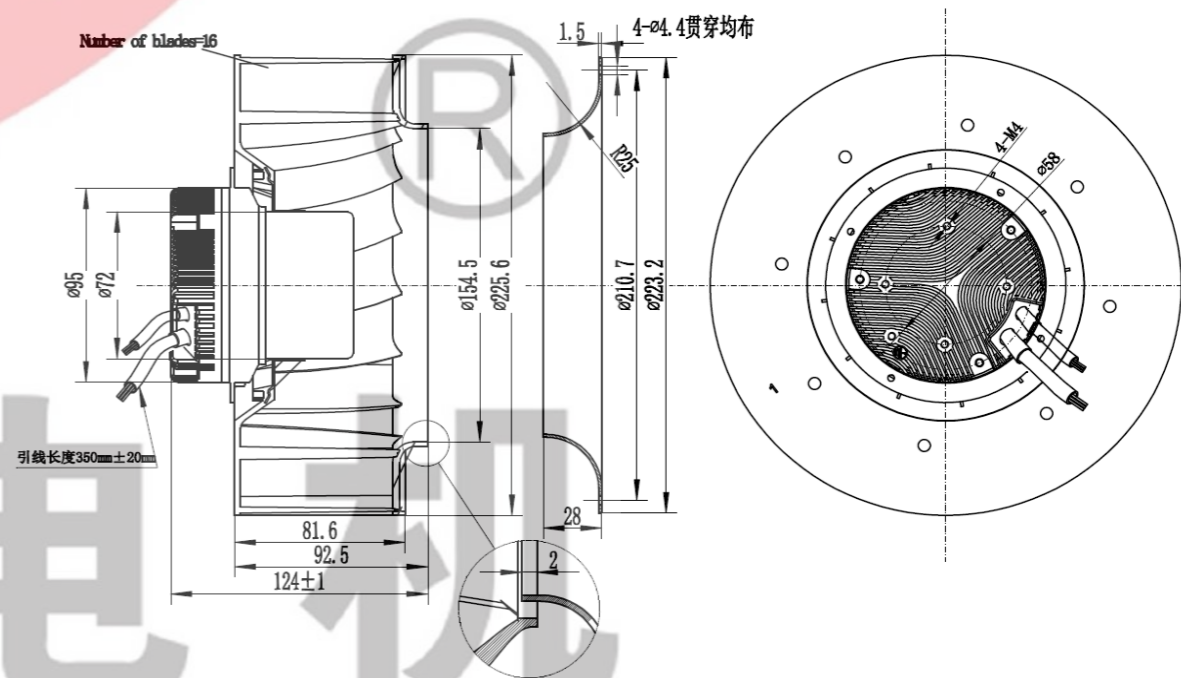
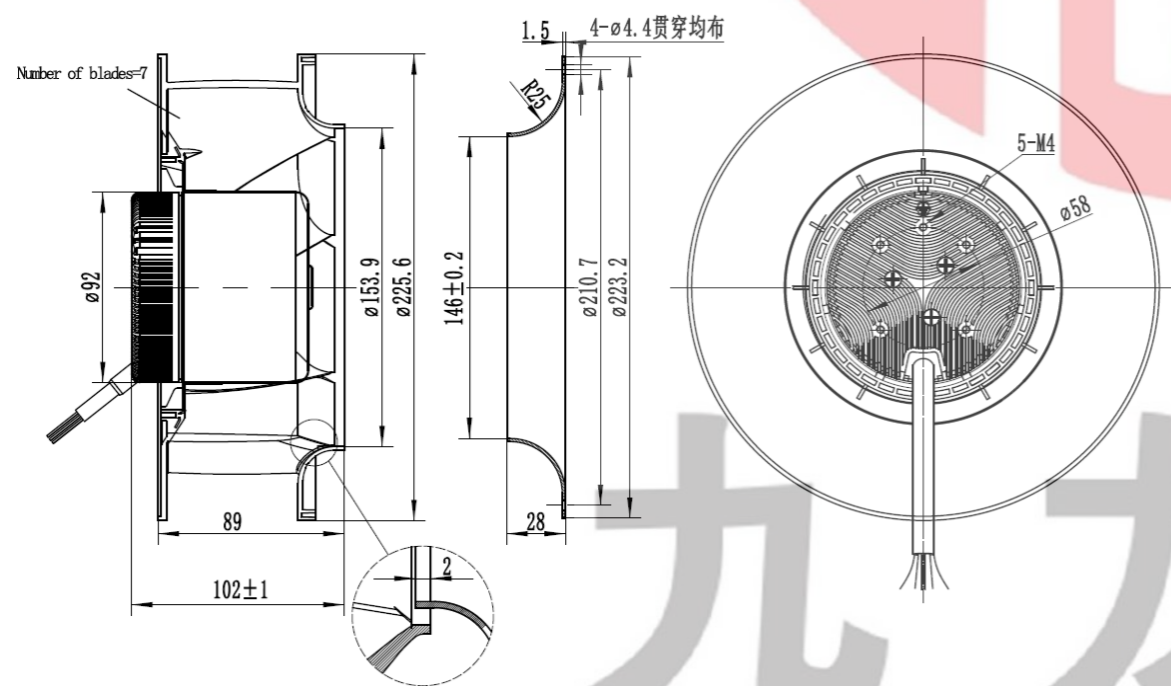

AC Axial Fan  
AC轴流风机

AC All-Metal Axial Fan  
AC全金属轴流风扇

DC Axial Fan  
DC轴流风机

DC Centrifugal Fan  
DC离心风机

EC Axial Fan  
EC轴流风机

EC Centrifugal Fan  
EC离心风机

AC Centrifugal Fan  
AC离心风机

Fan Accessories  
风机配件

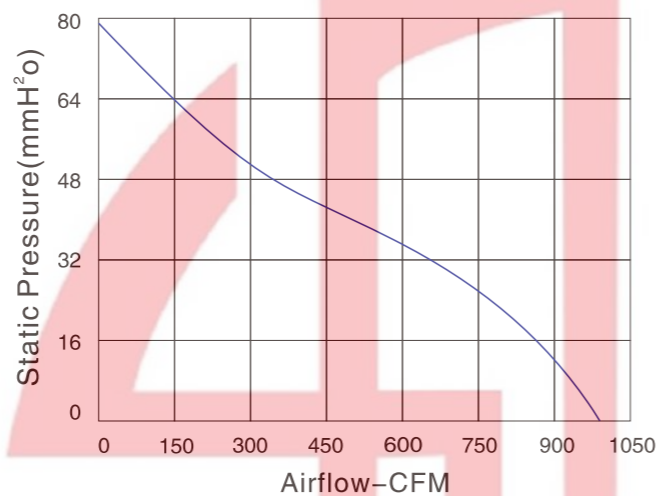

尺寸 Size: Ø250mmX81mm  
风量 Airflow: 985.4CFM  
噪音 Noise: 78.1dB(A)  
风叶 Impeller Material: Metal  
工作方式 Operation mode: S1  
温度范围 Operating Temperature: -10°C~+65°C  
防护等级 Type of protection: IP44  
绝缘等级 Insulation class: "B"

产品型号 Model	电压 Voltage VDC	电流 Current A	功率 Power W	转速 Speed RPM	风量 Air Flow CFM	静压 Static Pressure mmH <sub>2</sub> O	噪音 Noise dB(A)
YDH250AHD3-A01	310	0.58	180	3000	985.4	78.7	78.1

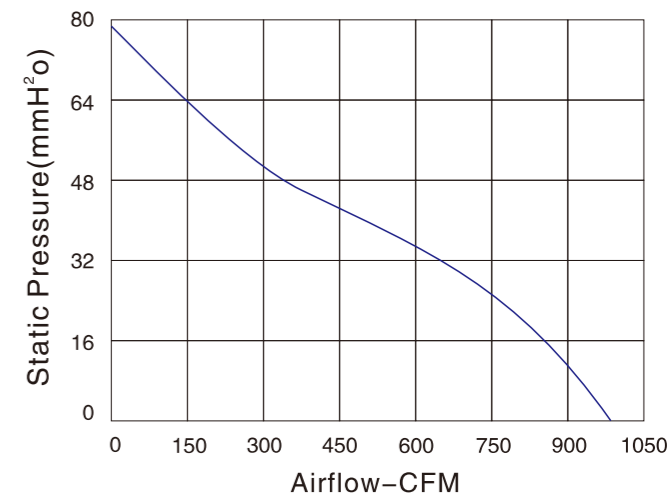
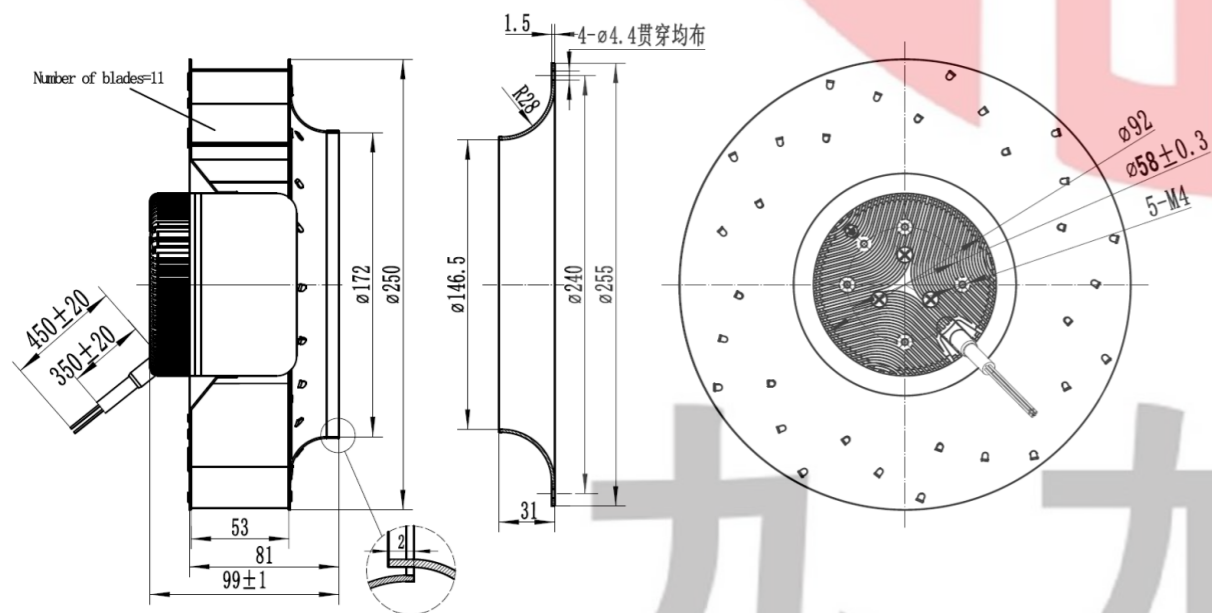

尺寸 Size: Ø250mmX86mm  
风量 Airflow: 985.4CFM  
噪音 Noise: 78.1dB(A)  
风叶 Impeller Material: PA66  
工作方式 Operation mode: S1  
温度范围 Operating Temperature: -10°C~+65°C  
防护等级 Type of protection: IP44  
绝缘等级 Insulation class: "B"

产品型号 Model	电压 Voltage VDC	电流 Current A	功率 Power W	转速 Speed RPM	风量 Air Flow CFM	静压 Static Pressure mmH <sub>2</sub> O	噪音 Noise dB(A)
YDH250BHD3-A01	310	0.55	170	3000	985.4	78.7	78.1

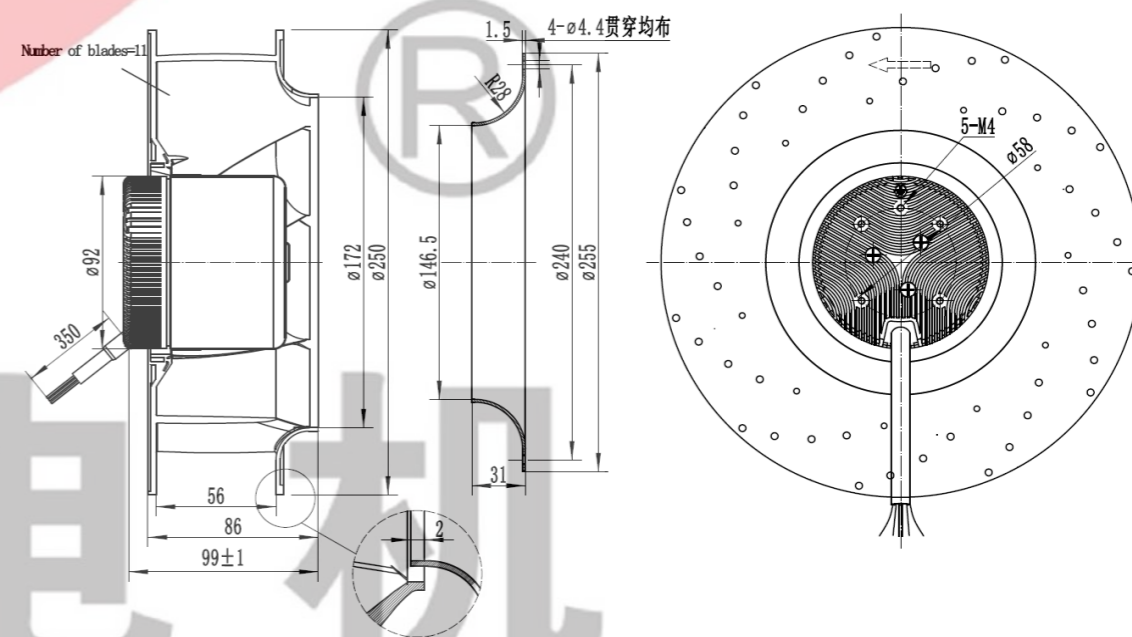

九 龙 电 机

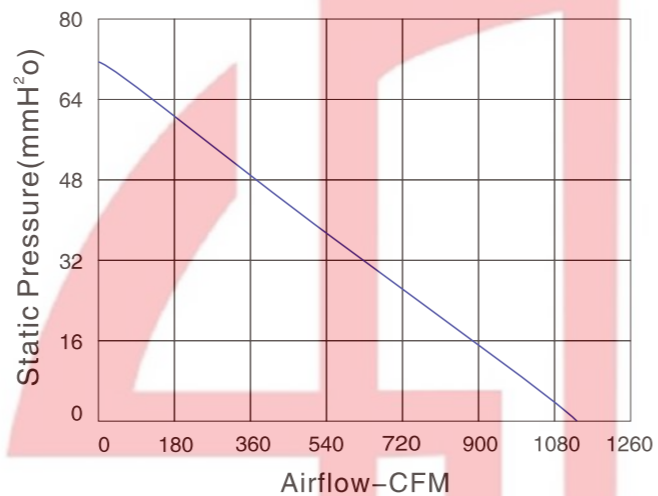

尺寸 Size: Ø280mmX81mm  
风量 Airflow: 1126CFM  
噪音 Noise: 74.6dB(A)  
风叶 Impeller Material: Metal  
工作方式 Operation mode: S1  
温度范围 Operating Temperature: -10°C~+65°C  
防护等级 Type of protection: IP44  
绝缘等级 Insulation class: "B"

产品型号 Model	电压 Voltage VDC	电流 Current A	功率 Power W	转速 Speed RPM	风量 Air Flow CFM	静压 Static Pressure mmH <sub>2</sub> O	噪音 Noise dB(A)
YDH280AHD3-A01	310	0.48	150	2500	1126	71.5	74.6

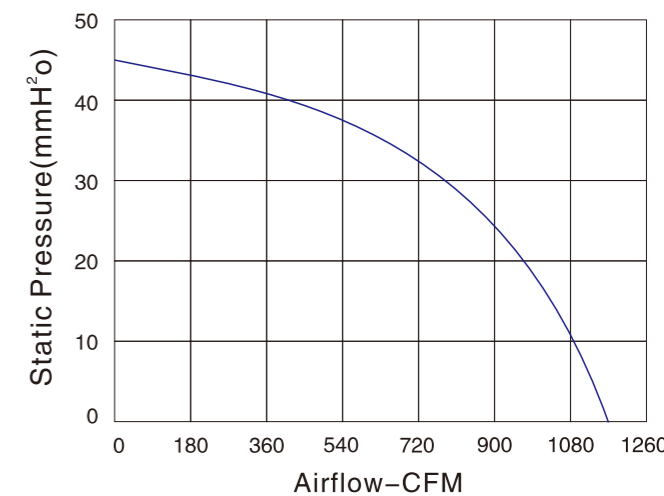
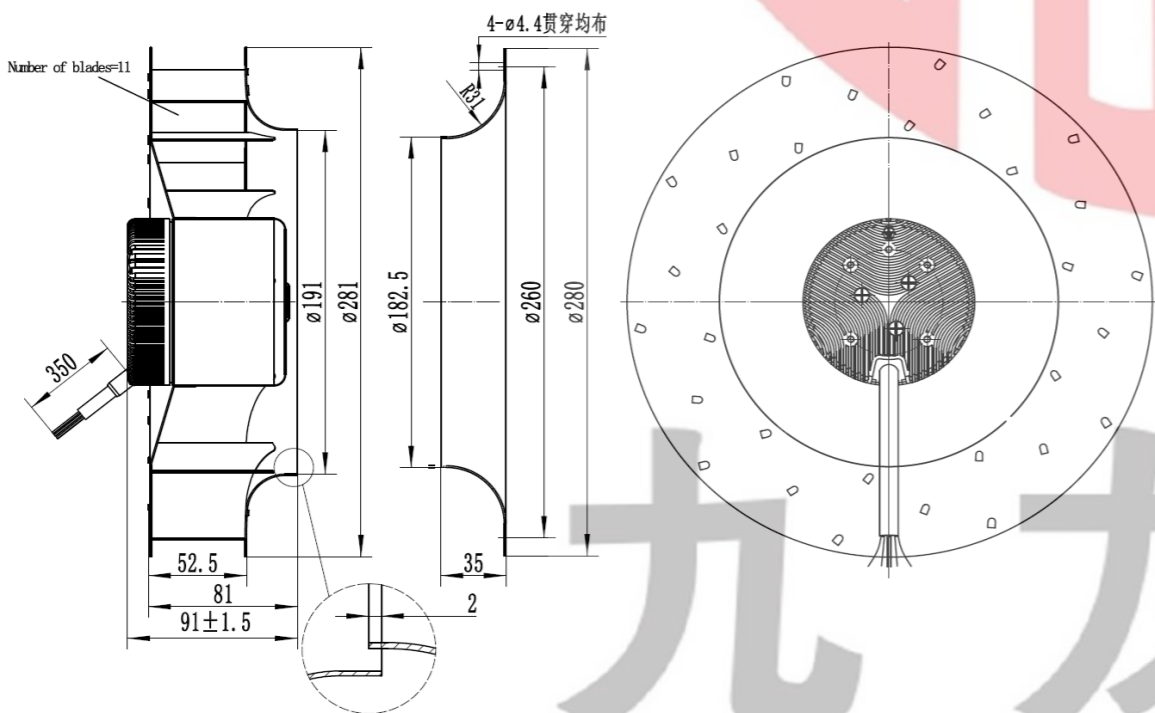

尺寸 Size: Ø280mmX112mm  
风量 Airflow: 1167CFM  
噪音 Noise: 45dB(A)  
风叶 Impeller Material: Metal  
工作方式 Operation mode: S1  
温度范围 Operating Temperature: -10°C~+65°C  
防护等级 Type of protection: IP44  
绝缘等级 Insulation class: "B"

产品型号 Model	电压 Voltage VDC	电流 Current A	功率 Power W	转速 Speed RPM	风量 Air Flow CFM	静压 Static Pressure mmH <sub>2</sub> O	噪音 Noise dB(A)
YDH280BHD3-A01	310	0.42	130	2000	1167	45	70.2

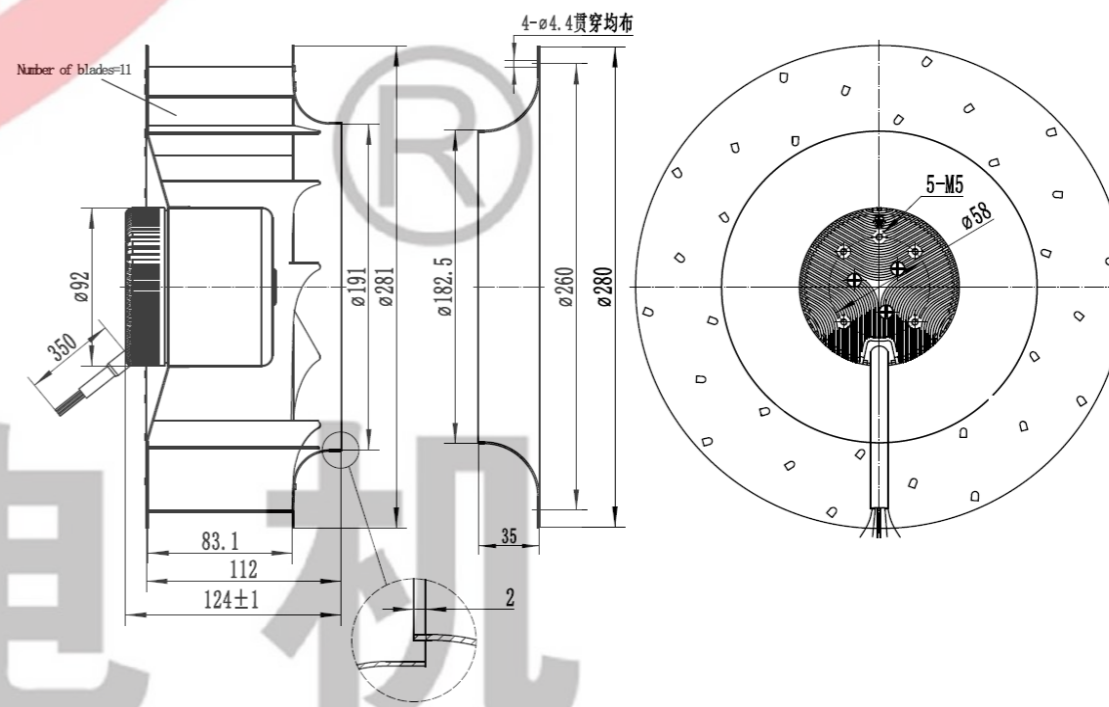

九 龙 电 机



JULONG MOTOR  
AC/DC FANS COOLING FANS



本样图仅供参考，具体以实物为准。  
This sample book is for reference only. Please refer to the specification for details.  
如需特殊电压也可根据需求提供。本公司保留技术知识产权。  
Special voltage may be provided flexibly according to the requirement. All technical modification rights reserved.

Http://www.xtgygs.cn

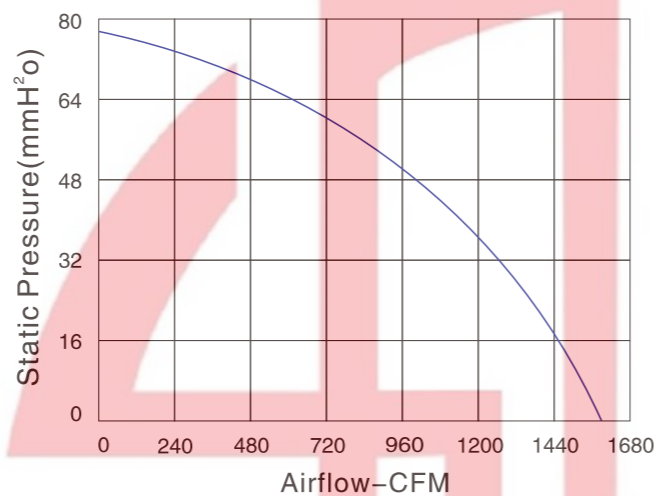

尺寸 Size: Ø320mmX108mm  
风量 Airflow: 1579CFM  
噪音 Noise: 72.9dB(A)  
风叶 Impeller Material: Aluminium  
工作方式 Operation mode: S1  
温度范围 Operating Temperature: -10°C~+65°C  
防护等级 Type of protection: IP44  
绝缘等级 Insulation class: "B"

产品型号 Model	电压 Voltage VDC	电流 Current A	功率 Power W	转速 Speed RPM	风量 Air Flow CFM	静压 Static Pressure mmH <sub>2</sub> O	噪音 Noise dB(A)
YDH320AID3-A01	310	0.97	300	2200	1579	77	72.9

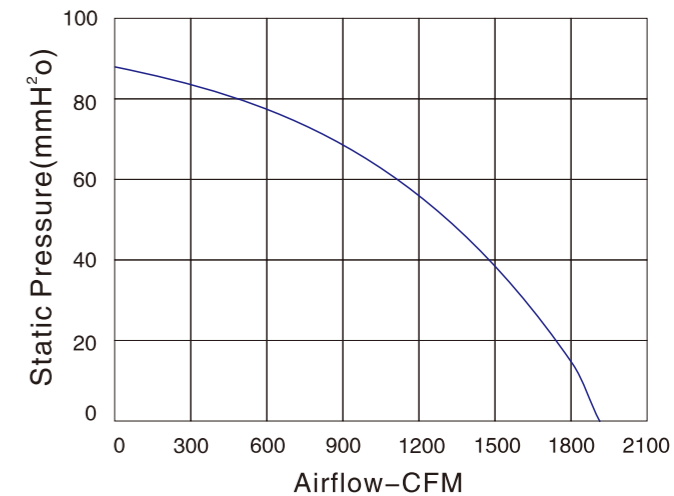
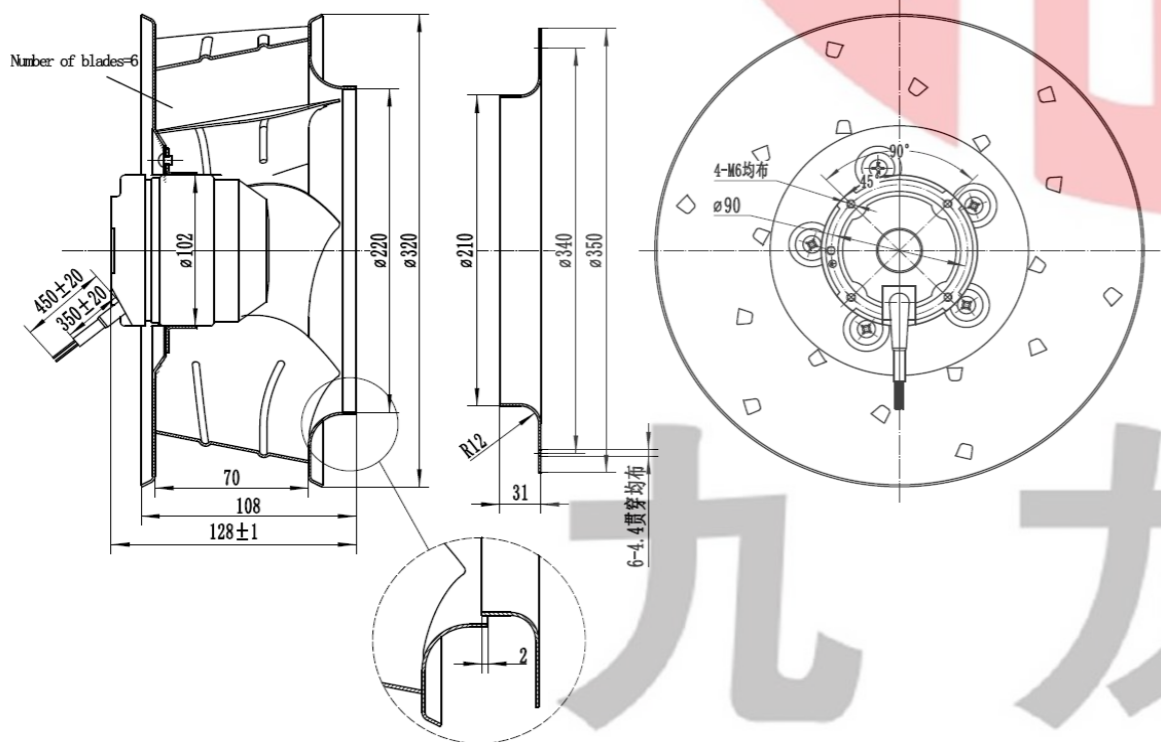

尺寸 Size: Ø320mmX140mm  
风量 Airflow: 1928CFM  
噪音 Noise: 75.9dB(A)  
风叶 Impeller Material: Aluminium  
工作方式 Operation mode: S1  
温度范围 Operating Temperature: -10°C~+65°C  
防护等级 Type of protection: IP44  
绝缘等级 Insulation class: "B"

产品型号 Model	电压 Voltage VDC	电流 Current A	功率 Power W	转速 Speed RPM	风量 Air Flow CFM	静压 Static Pressure mmH <sub>2</sub> O	噪音 Noise dB(A)
YDH320BID3-A01	310	1	320	2200	1928	89.4	75.9

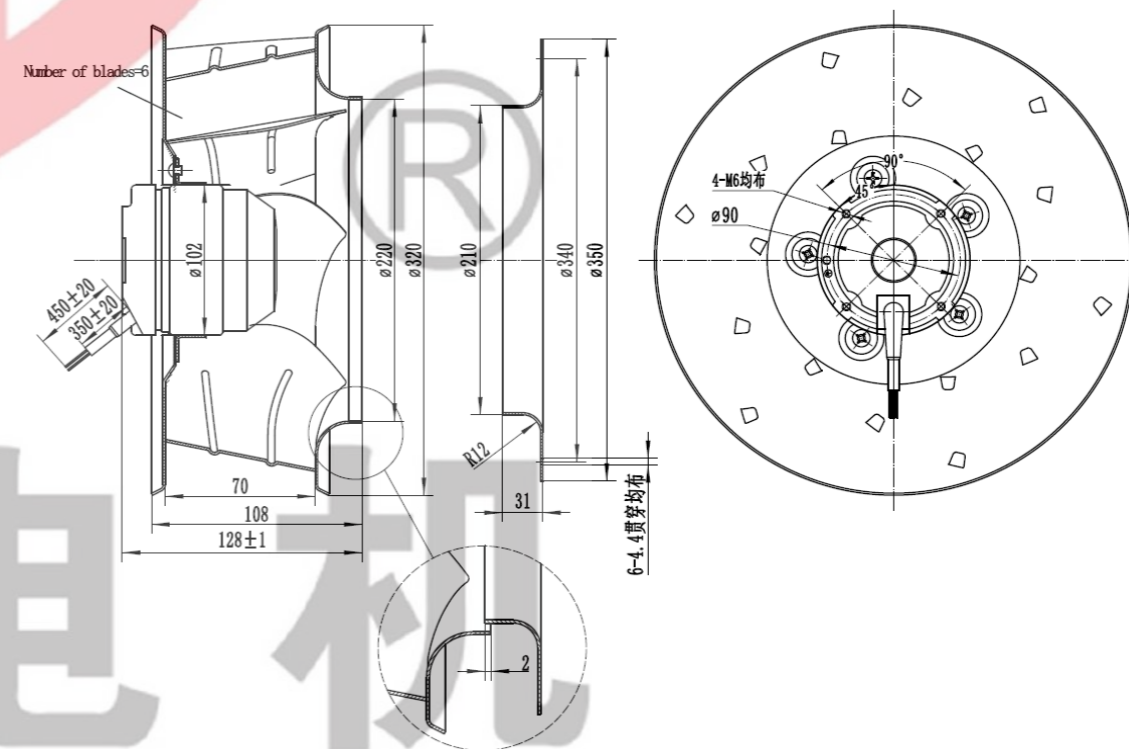

九 龙 电 机

AC Axial Fan  
AC轴流风机

AC All-Metal Axial Fan  
AC全金属轴流风扇

DC Axial Fan  
DC轴流风机

DC Centrifugal Fan  
DC离心风机

EC Axial Fan  
EC轴流风机

EC Centrifugal Fan  
EC离心风机

AC Centrifugal Fan  
AC离心风机

Fan Accessories  
风机配件



JIULONG MOTOR  
AC/DC FANS COOLING FANS



UL  
E248719



本样图仅供参考，具体以实物为准。  
This sample book is for reference only. Please refer to the specification for details.  
如需特殊电压也可根据需求提供。本公司保留技术更改权利。  
Special voltage may be provided according to the enquiry. All rights reserved.

Http://www.xtgygs.cn

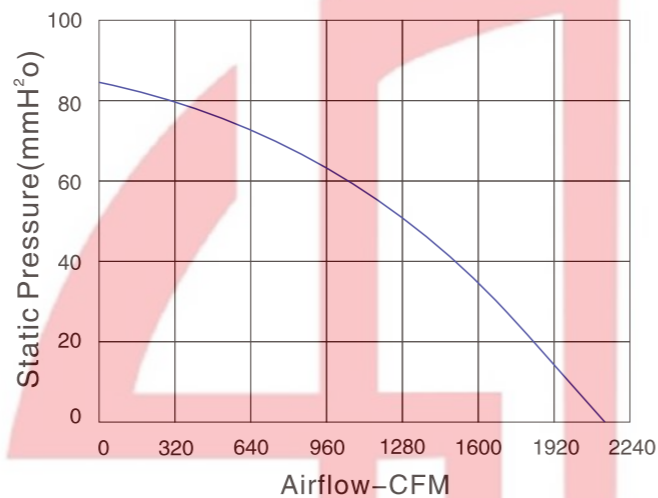

尺寸 Size: Ø335mmX147mm  
风量 Airflow: 2122CFM  
噪音 Noise: 73.4dB(A)  
风叶 Impeller Material: Aluminium  
工作方式 Operation mode: S1  
温度范围 Operating Temperature: -10°C~+65°C  
防护等级 Type of protection: IP44  
绝缘等级 Insulation class: "B"

产品型号 Model	电压 Voltage VDC	电流 Current A	功率 Power W	转速 Speed RPM	风量 Air Flow CFM	静压 Static Pressure mmH <sub>2</sub> O	噪音 Noise dB(A)
YDH355BID3-A01	310	1.1	330	1900	2122	84.3	73.4

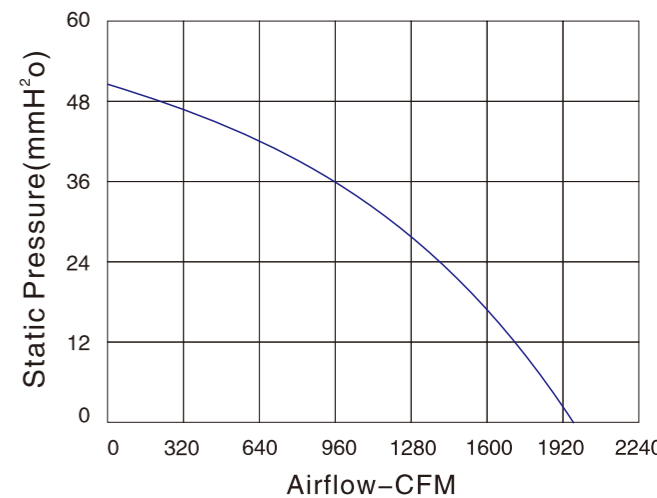
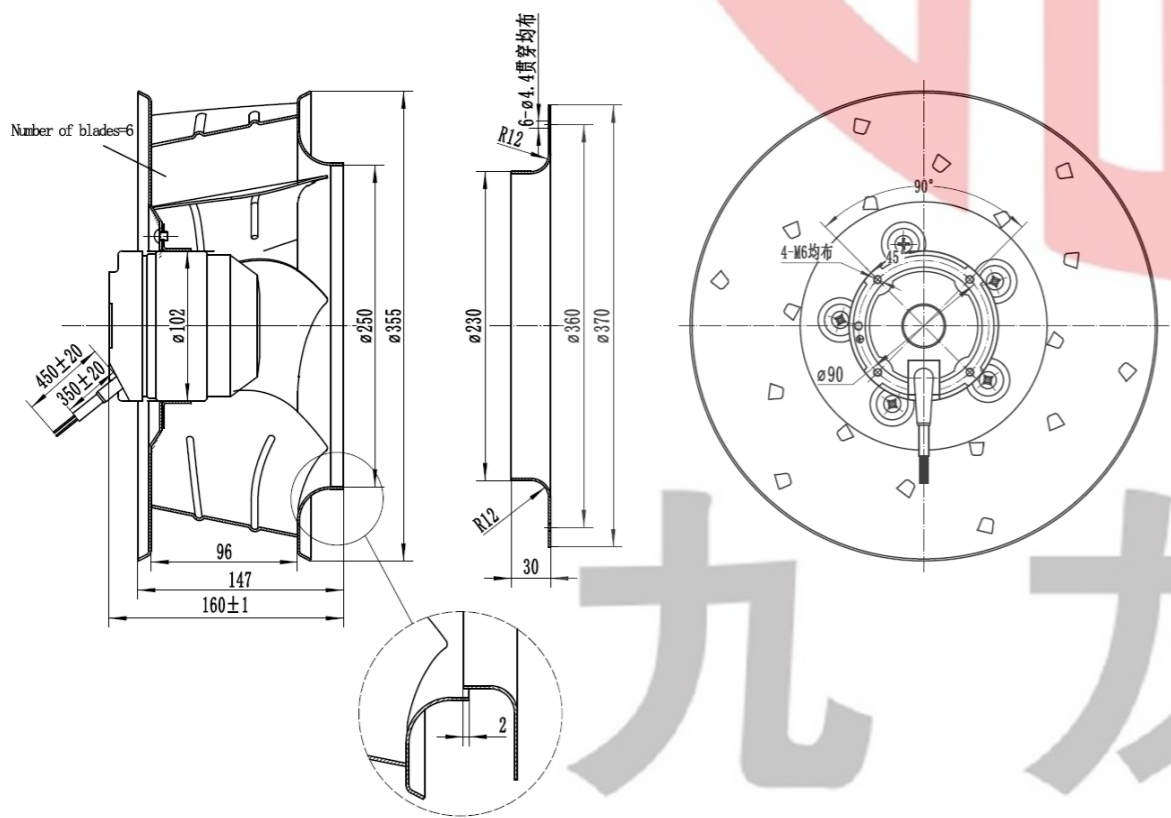

尺寸 Size: Ø400mmX140mm  
风量 Airflow: 1943CFM  
噪音 Noise: 68dB(A)  
风叶 Impeller Material: Aluminium  
工作方式 Operation mode: S1  
温度范围 Operating Temperature: -10°C~+65°C  
防护等级 Type of protection: IP44  
绝缘等级 Insulation class: "B"

产品型号 Model	电压 Voltage VDC	电流 Current A	功率 Power W	转速 Speed RPM	风量 Air Flow CFM	静压 Static Pressure mmH <sub>2</sub> O	噪音 Noise dB(A)
YDH400AID3-A01	310	0.8	245	1450	1943	51	68

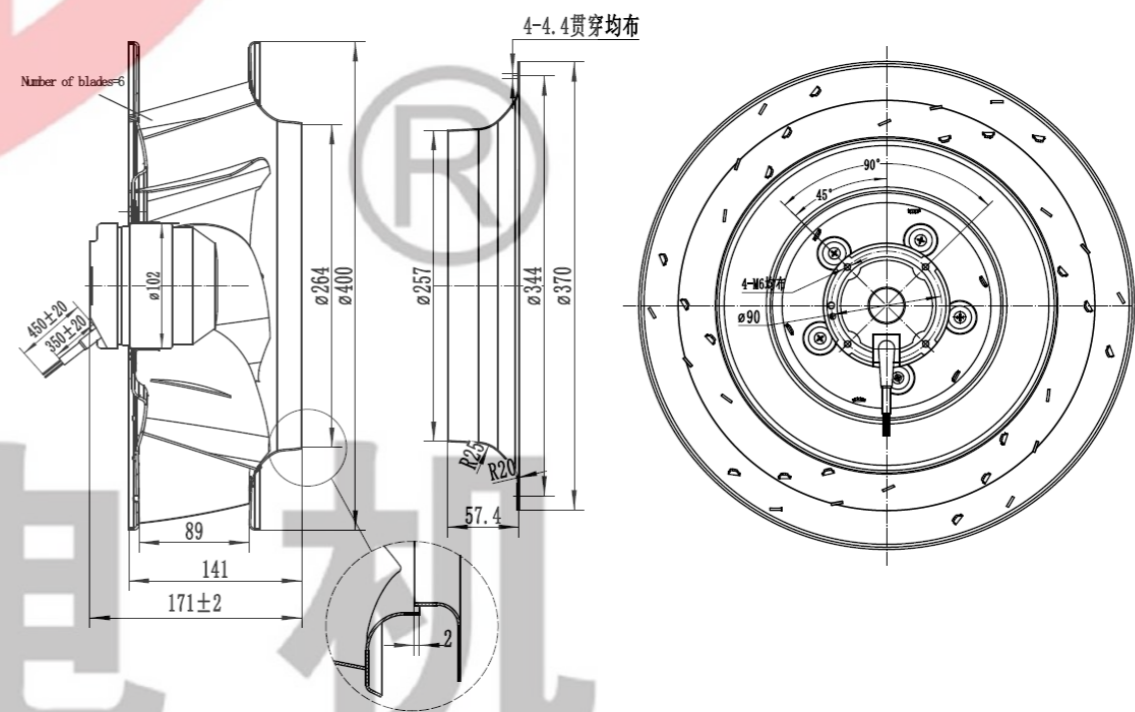

九 龙 电 机

AC Axial Fan  
AC轴流风机

AC All-Metal Axial Fan  
AC全金属轴流风扇

DC Axial Fan  
DC轴流风机

DC Centrifugal Fan  
DC离心风机

EC Axial Fan  
EC轴流风机

EC Centrifugal Fan  
EC离心风机

AC Centrifugal Fan  
AC离心风机

Fan Accessories  
风机配件

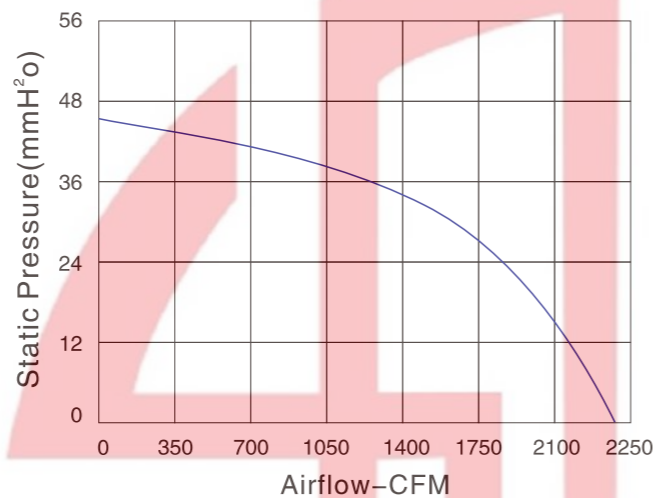

尺寸 Size: Ø400mmX188mm  
风量 Airflow: 2355CFM  
噪音 Noise: 68dB(A)  
风叶 Impeller Material: Aluminium  
工作方式 Operation mode: S1  
温度范围 Operating Temperature: -10°C~+65°C  
防护等级 Type of protection: IP44  
绝缘等级 Insulation class: "B"

产品型号 Model	电压 Voltage VDC	电流 Current A	功率 Power W	转速 Speed RPM	风量 Air Flow CFM	静压 Static Pressure mmH <sub>2</sub> O	噪音 Noise dB(A)
YDH400BID3-A01	310	1	320	1350	2355	44.8	68

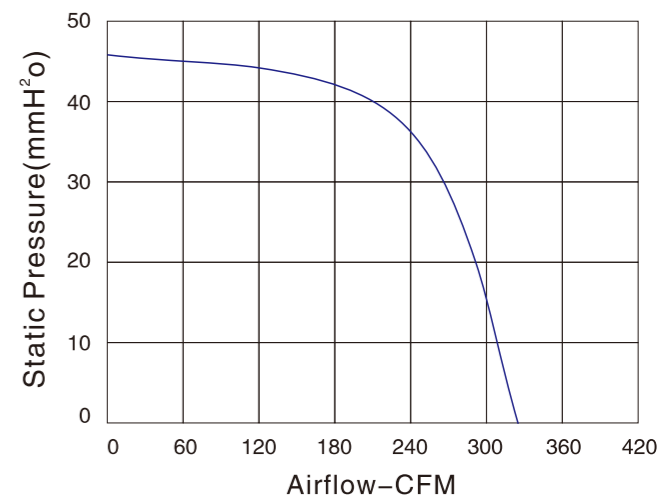
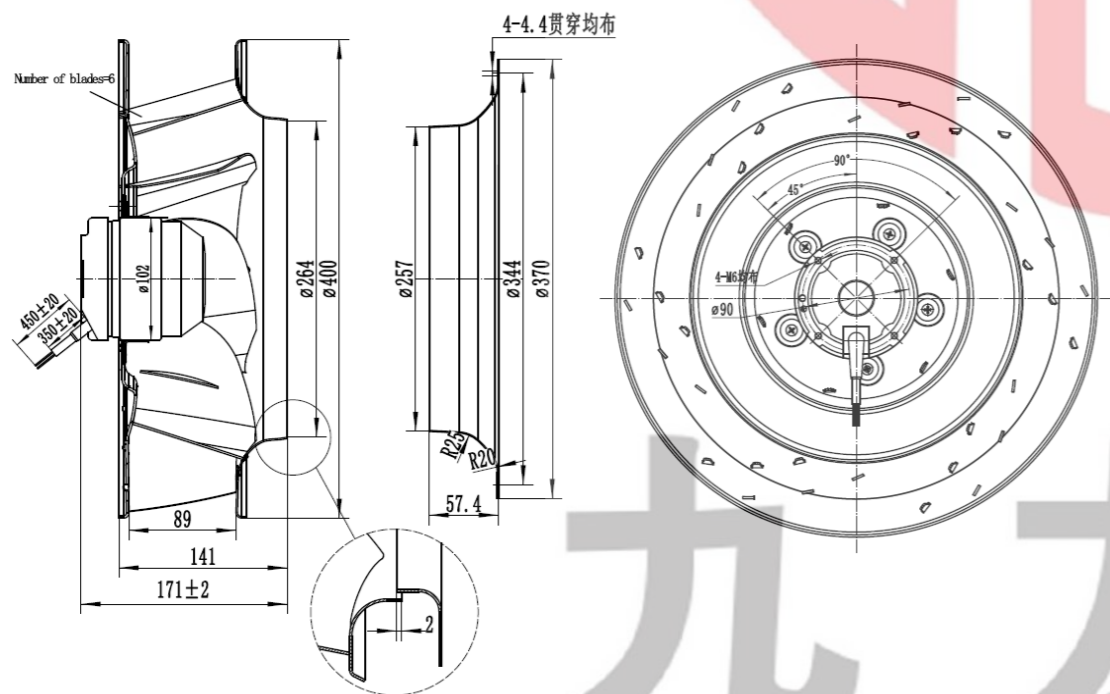

尺寸 Size: Ø120mmX122mm  
风量 Airflow: 323.5CFM  
噪音 Noise: 62.2dB(A)  
风叶 Impeller Material: Metal  
工作方式 Operation mode: S1  
温度范围 Operating Temperature: -10°C~+65°C  
防护等级 Type of protection: IP44  
绝缘等级 Insulation class: "B"

产品型号 Model	电压 Voltage VDC	电流 Current A	功率 Power W	转速 Speed RPM	风量 Air Flow CFM	静压 Static Pressure mmH <sub>2</sub> O	噪音 Noise dB(A)
YDS120BGD3-C01-W	310	0.3	94	2000	323.5	46.1	62.3

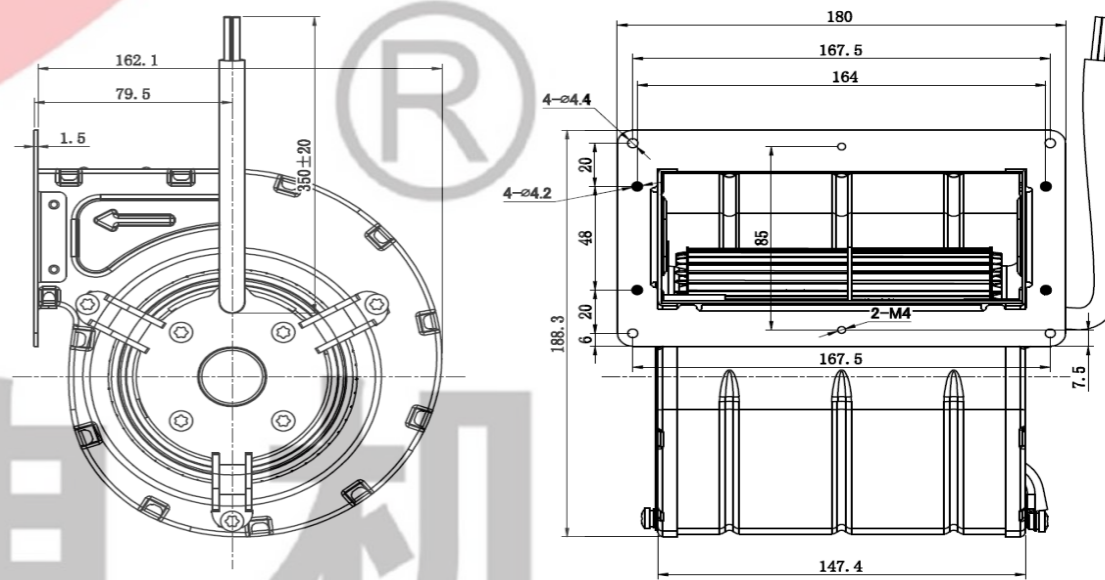

九 龙 电 机

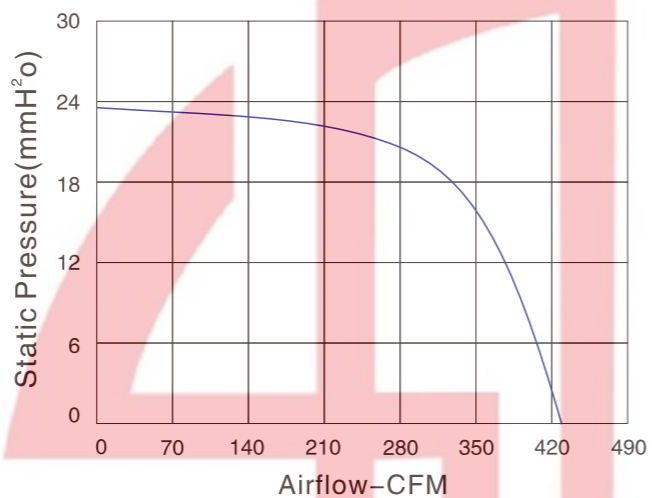

尺寸 Size: Ø133mmX190mm  
风量 Airflow: 427.8CFM  
噪音 Noise: 56.7dB(A)  
风叶 Impeller Material: Metal  
工作方式 Operation mode: S1  
温度范围 Operating Temperature: -10°C~+65°C  
防护等级 Type of protection: IP44  
绝缘等级 Insulation class: "B"

产品型号 Model	电压 Voltage VDC	电流 Current A	功率 Power W	转速 Speed RPM	风量 Air Flow CFM	静压 Static Pressure mmH <sub>2</sub> O	噪音 Noise dB(A)
YDS133BGD3-A01-W	310	0.35	108	1600	427.8	23.7	56.7

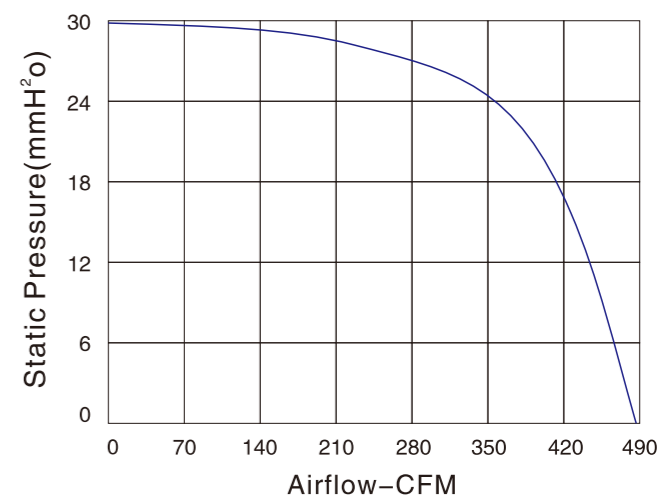

尺寸 Size: Ø133mmX190mm  
风量 Airflow: 481.3CFM  
噪音 Noise: 59.3dB(A)  
风叶 Impeller Material: Metal  
工作方式 Operation mode: S1  
温度范围 Operating Temperature: -10°C~+65°C  
防护等级 Type of protection: IP44  
绝缘等级 Insulation class: "B"

产品型号 Model	电压 Voltage VDC	电流 Current A	功率 Power W	转速 Speed RPM	风量 Air Flow CFM	静压 Static Pressure mmH <sub>2</sub> O	噪音 Noise dB(A)
YDS133BHD3-A01-W	310	0.51	158	1800	481.3	30	59.3

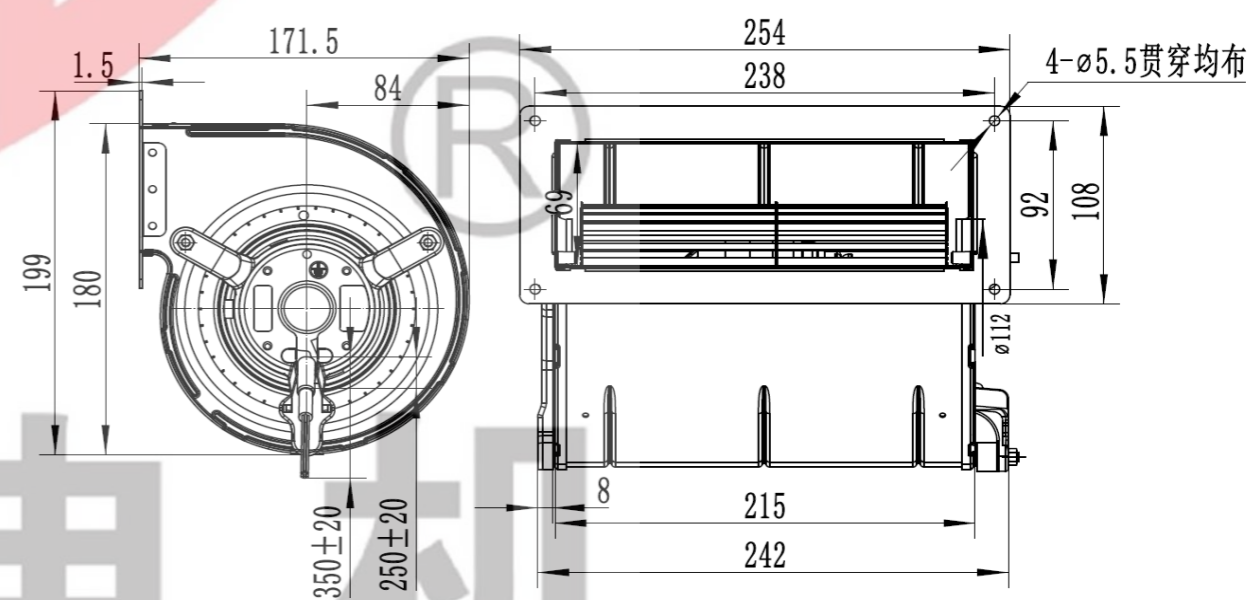
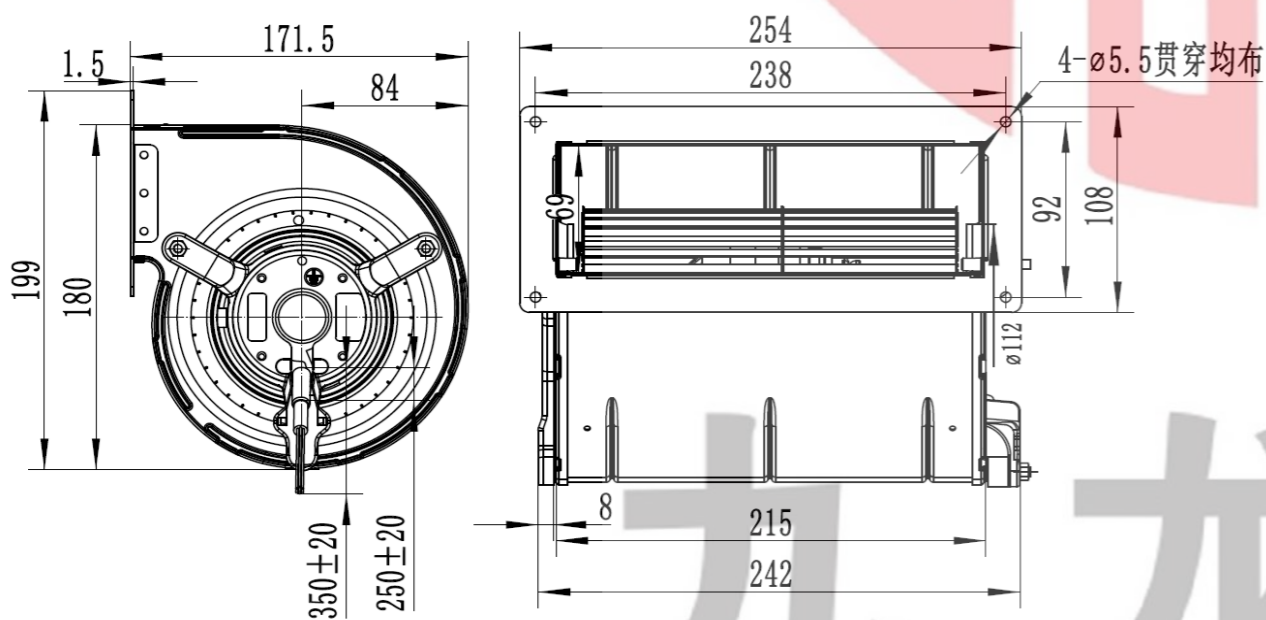

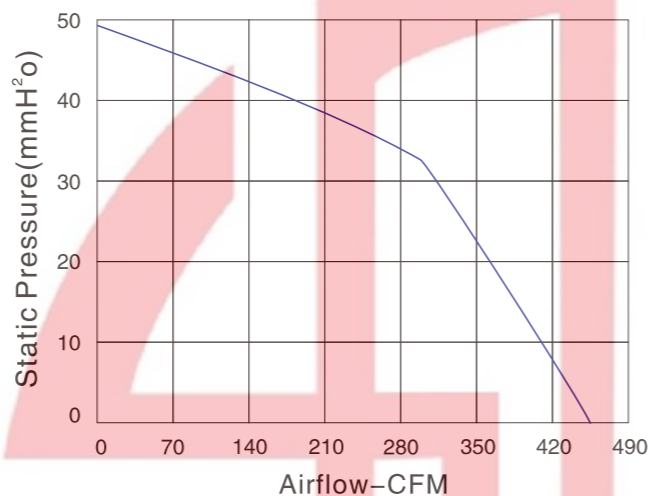

尺寸 Size: Ø146mmX150mm  
风量 Airflow: 459.6CFM  
噪音 Noise: 50.5dB(A)  
风叶 Impeller Material: PP  
工作方式 Operation mode: S1  
温度范围 Operating Temperature: -10°C~+65°C  
防护等级 Type of protection: IP44  
绝缘等级 Insulation class: "B"

产品型号 Model	电压 Voltage VDC	电流 Current A	功率 Power W	转速 Speed RPM	风量 Air Flow CFM	静压 Static Pressure mmH <sub>2</sub> O	噪音 Noise dB(A)
YDS146AGD3-C01-W	310	0.37	115	1600	459.6	49.6	50.5

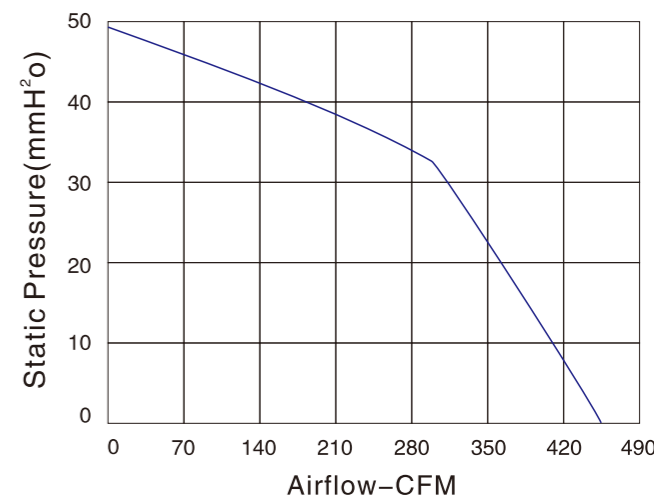

尺寸 Size: Ø146mmX150mm  
风量 Airflow: 671.2CFM  
噪音 Noise: 68dB(A)  
风叶 Impeller Material: PP  
工作方式 Operation mode: S1  
温度范围 Operating Temperature: -10°C~+65°C  
防护等级 Type of protection: IP44  
绝缘等级 Insulation class: "B"

产品型号 Model	电压 Voltage VDC	电流 Current A	功率 Power W	转速 Speed RPM	风量 Air Flow CFM	静压 Static Pressure mmH <sub>2</sub> O	噪音 Noise dB(A)
YDS146AHD3-A01-W	310	0.58	180	2000	671.2	45.9	68

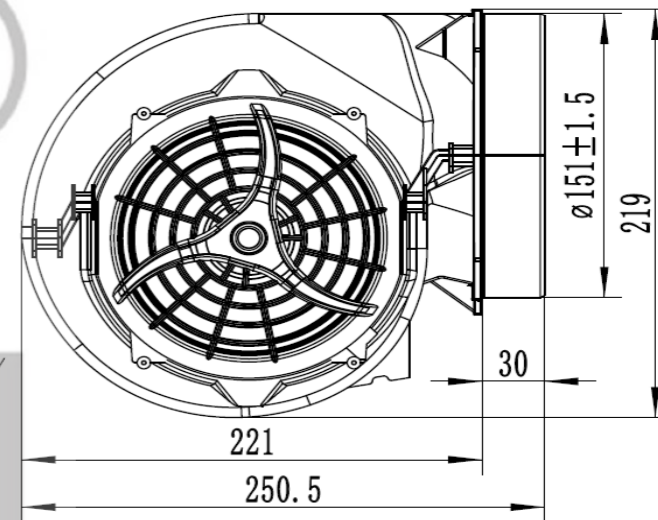
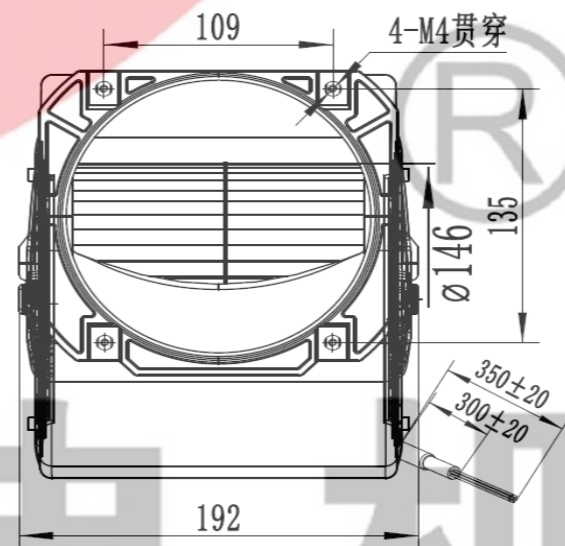
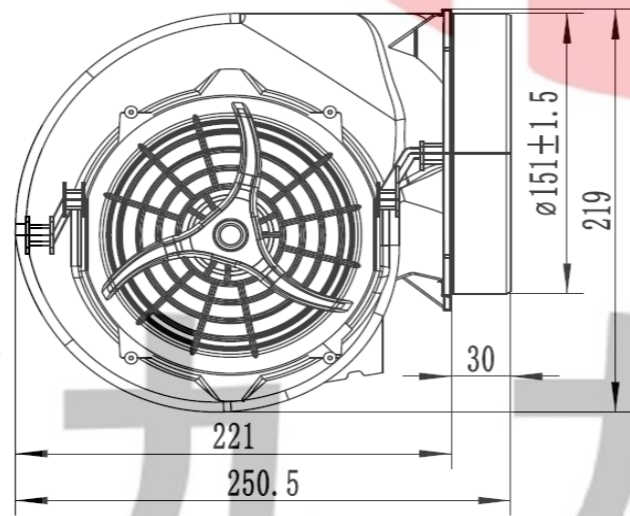
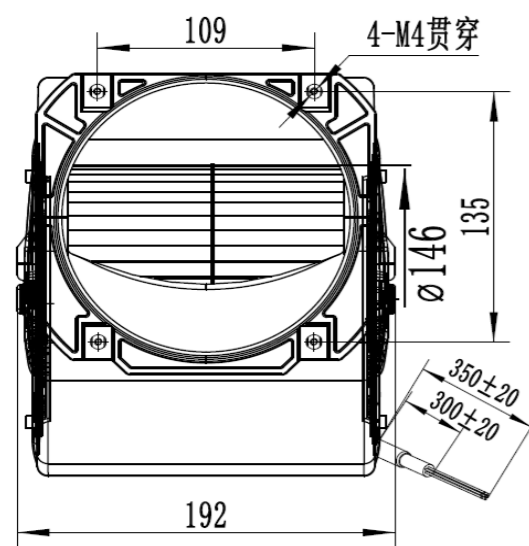

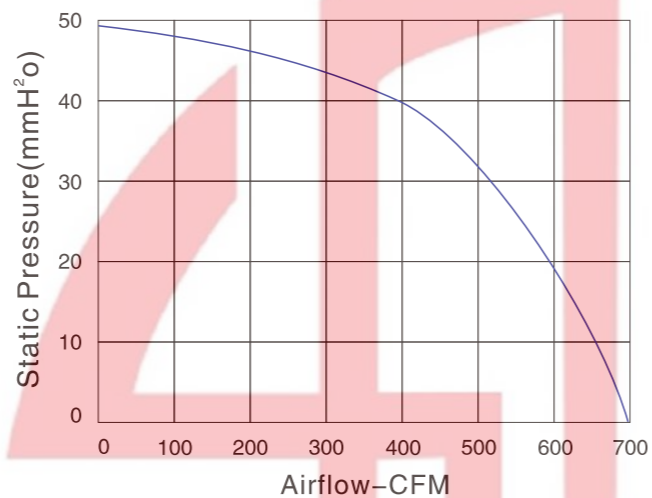

尺寸 Size: Ø146mmX190mm  
风量 Airflow: 700CFM  
噪音 Noise: 63.8dB(A)  
风叶 Impeller Material: Metal  
工作方式 Operation mode: S1  
温度范围 Operating Temperature: -10°C~+65°C  
防护等级 Type of protection: IP44  
绝缘等级 Insulation class: "B"

产品型号 Model	电压 Voltage VDC	电流 Current A	功率 Power W	转速 Speed RPM	风量 Air Flow CFM	静压 Static Pressure mmH <sub>2</sub> O	噪音 Noise dB(A)
YDS146BGD3-C01-W	310	0.58	170	1600	700	49.2	63.8

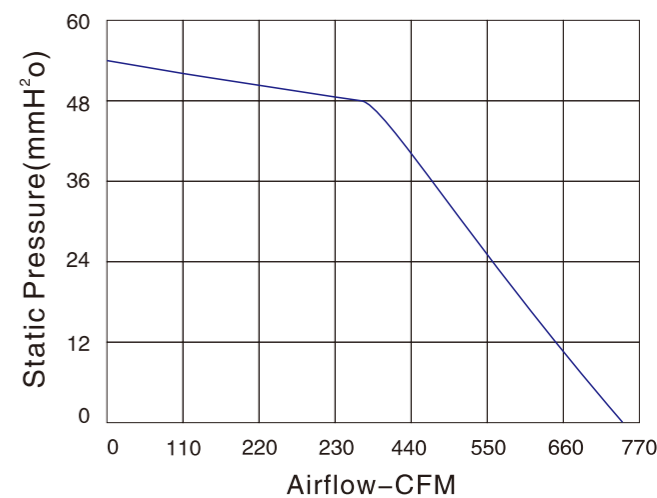
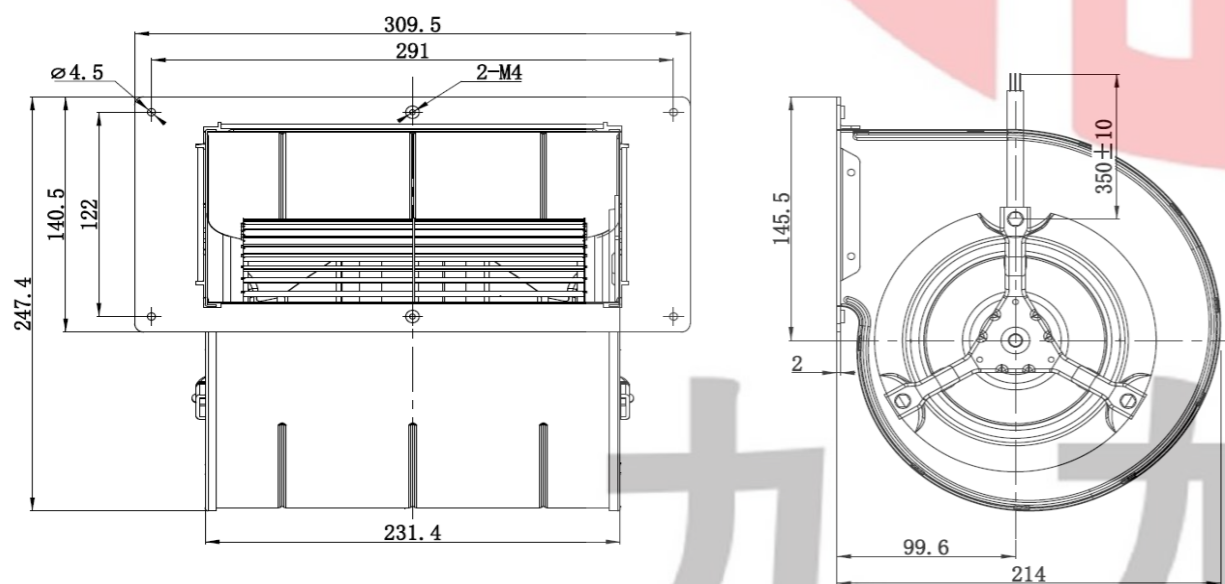

尺寸 Size: Ø146mmX190mm  
风量 Airflow: 742.8CFM  
噪音 Noise: 55.5dB(A)  
风叶 Impeller Material: Metal  
工作方式 Operation mode: S1  
温度范围 Operating Temperature: -10°C~+65°C  
防护等级 Type of protection: IP44  
绝缘等级 Insulation class: "B"

产品型号 Model	电压 Voltage VDC	电流 Current A	功率 Power W	转速 Speed RPM	风量 Air Flow CFM	静压 Static Pressure mmH <sub>2</sub> O	噪音 Noise dB(A)
YDS146BHD3-A01-W	310	0.66	200	1700	742.8	55.5	64.5

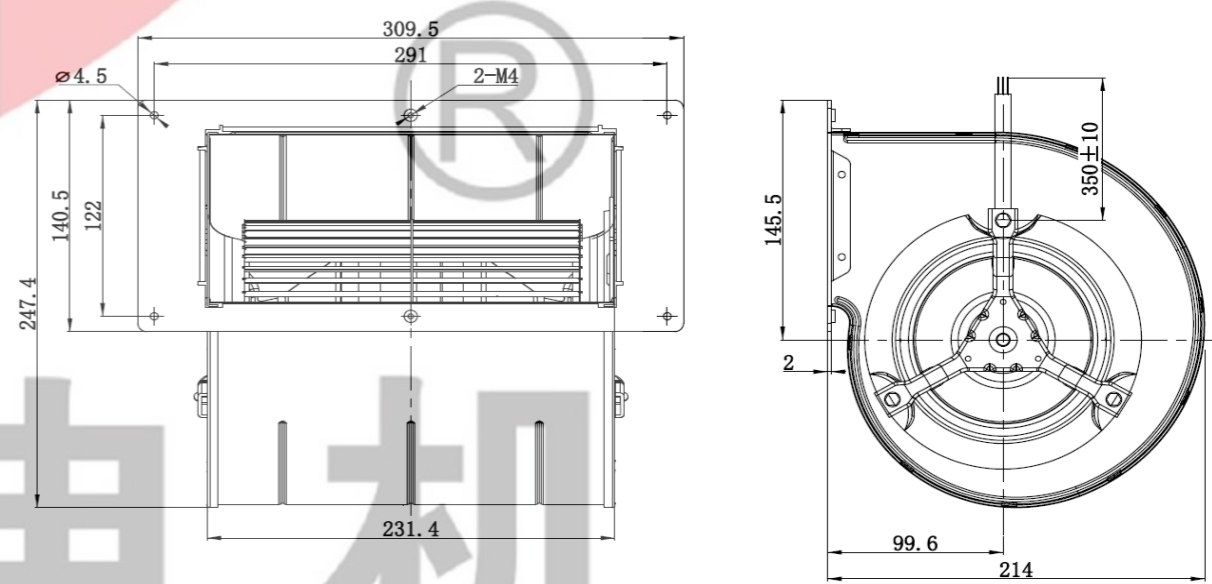



JULONG MOTOR  
AC/DC FANS COOLING FANS



本样图仅供参考，具体以实物为准。  
This sample book is for reference only. Please refer to the specification for details.  
如需特殊电压也可特别定制提供。本公司保留技术知识产权。  
Special voltage may be provided flexibly according to the query. All technical modification rights reserved.

Http://www.xtgygs.cn

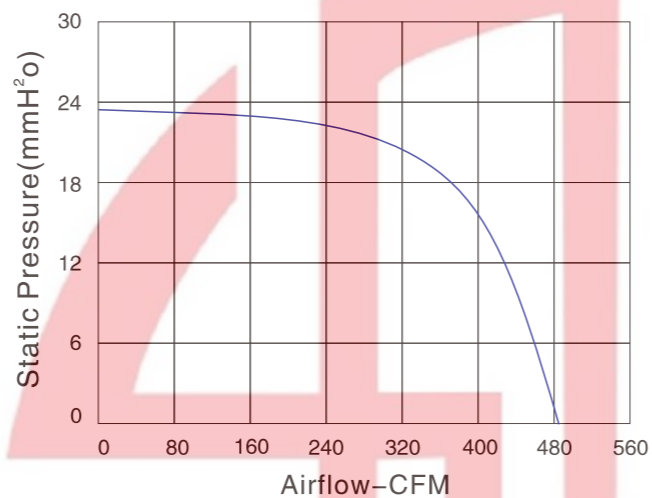

尺寸 Size: Ø151mmX195mm  
风量 Airflow: 481CFM  
噪音 Noise: 57.9dB(A)  
风叶 Impeller Material: Metal  
工作方式 Operation mode: S1  
温度范围 Operating Temperature: -10°C~+65°C  
防护等级 Type of protection: IP44  
绝缘等级 Insulation class: "B"

产品型号 Model	电压 Voltage VDC	电流 Current A	功率 Power W	转速 Speed RPM	风量 Air Flow CFM	静压 Static Pressure mmH <sub>2</sub> O	噪音 Noise dB(A)
YDS151AGD3-C01-W	310	0.38	118	1200	481	23	57.9

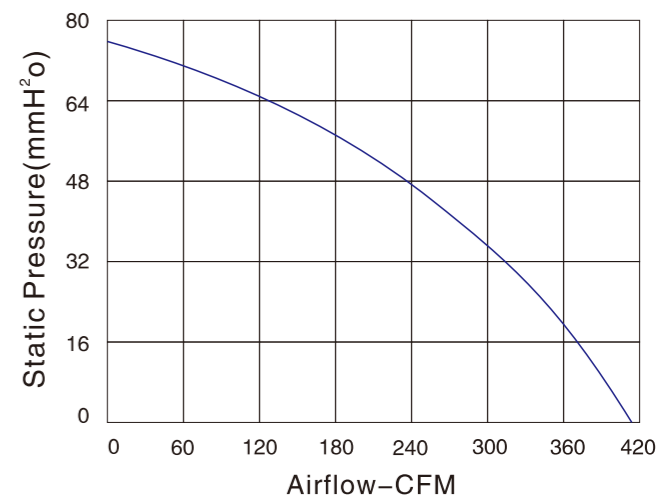
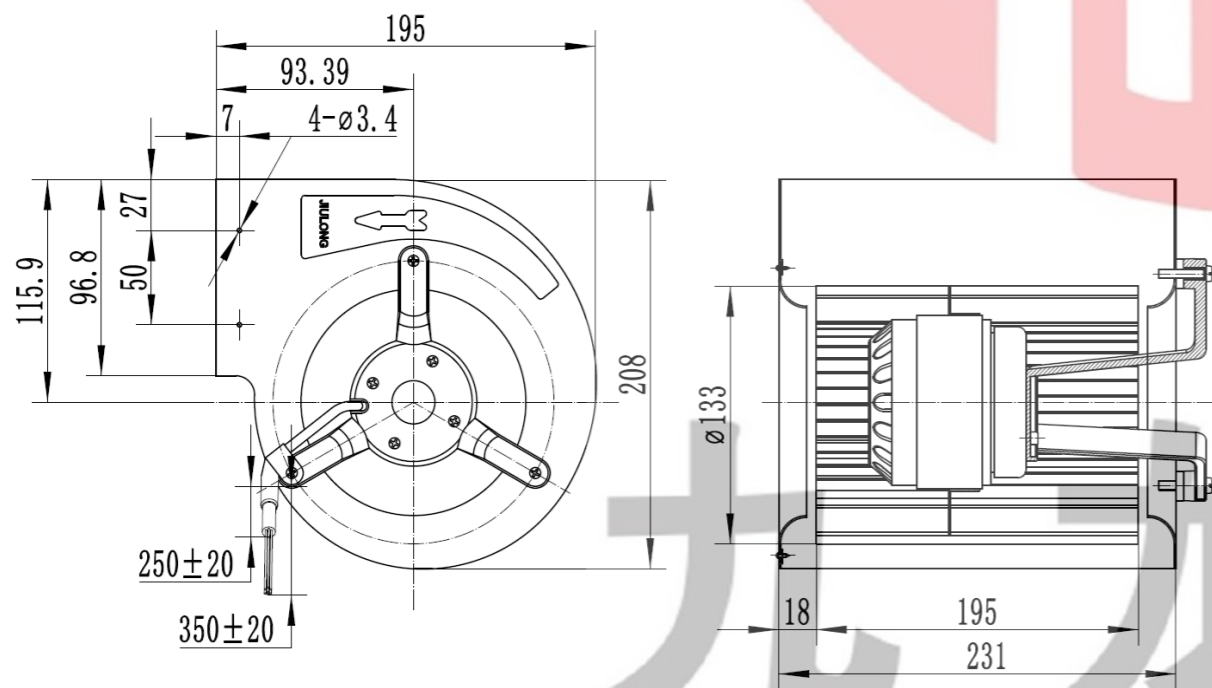

尺寸 Size: Ø160mmX75mm  
风量 Airflow: 412.4CFM  
噪音 Noise: 59.5dB(A)  
风叶 Impeller Material: Metal  
工作方式 Operation mode: S1  
温度范围 Operating Temperature: -10°C~+65°C  
防护等级 Type of protection: IP44  
绝缘等级 Insulation class: "B"

产品型号 Model	电压 Voltage VDC	电流 Current A	功率 Power W	转速 Speed RPM	风量 Air Flow CFM	静压 Static Pressure mmH <sub>2</sub> O	噪音 Noise dB(A)
YDS160AHD3-C01-W	310	0.36	110	1400	412.4	75.4	59.5

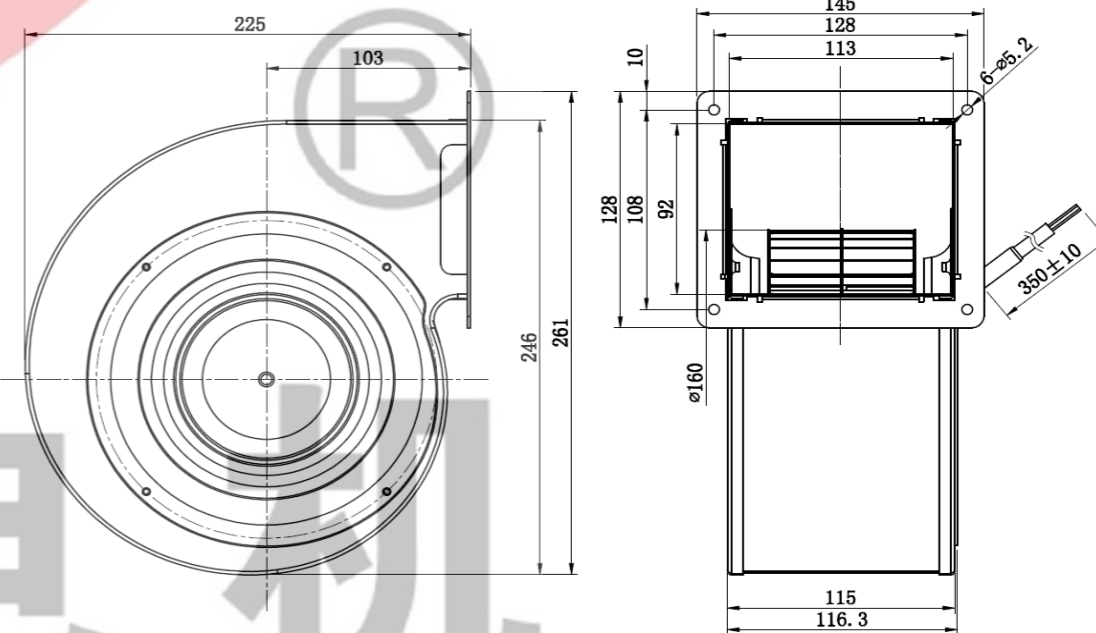

AC Axial Fan  
AC轴流风机

AC All-Metal Axial Fan  
AC全金属轴流风扇

DC Axial Fan  
DC轴流风机

DC Centrifugal Fan  
DC离心风机

EC Axial Fan  
EC轴流风机

EC Centrifugal Fan  
EC离心风机

AC Centrifugal Fan  
AC离心风机

Fan Accessories  
风机配件



JULONG MOTOR  
AC/DC FANS COOLING FANS



本样图仅供参考，具体以实物为准。  
This sample book is for reference only. Please refer to the specification for details.  
如需特殊电压也可特别定制提供。本公司保留技术知识产权。  
Special voltage may be provided flexibly according to the enquiry. All rights reserved.

Http://www.xtgygs.cn



### DIMENSIONS DRAWING

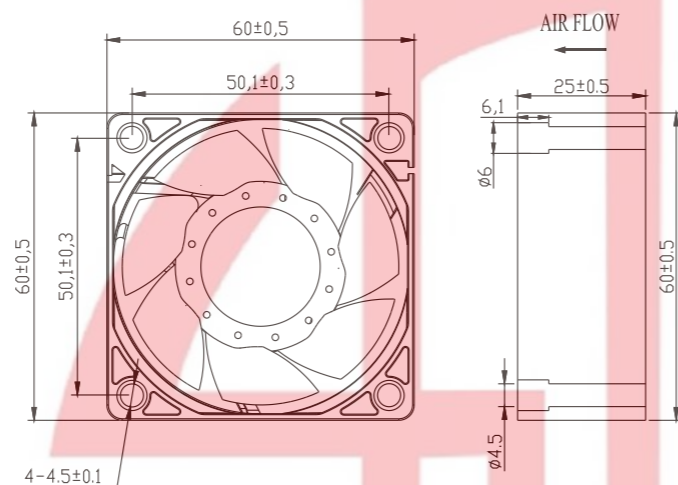

### 6025 EC FAN 60\*60\*25MM SERIES

Material  
UL 1007 AWG # 24 OR Equivalent  
Black Wire:AC

### P & Q CURVE (AT RATED VOLTAGE)

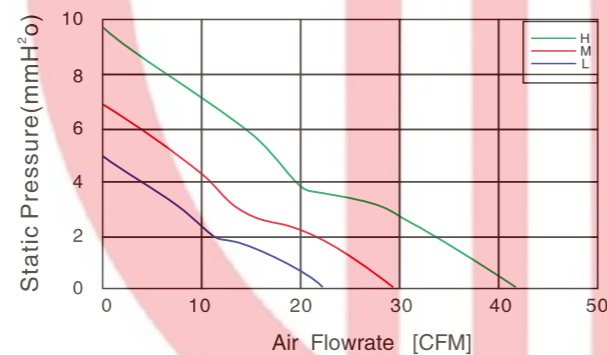

MODEL NO	RATED VOLTAGE ACV	OPERATING VOLTAGE ACV	RATED CURRENT A	RATED POWER W	RATED SPEED RPM (±10%)	MAX. AIR FLOW		MAX.STATIC AIR PRESSURE		NOISE LEVEL dbA
						CMM	CFM	InH2O	mmH2O	
JL6025HA2Y	220	85~265	0.02	4.6	5800	0.996	35.17	0.378	9.6	43.9
JL6025MA2Y	220	85~265	0.014	3.0	5000	0.83	29.32	0.263	6.67	40.0
JL6025LA2Y	220	85~265	0.008	1.8	4200	0.668	23.58	0.189	4.81	35.7



### DIMENSIONS DRAWING

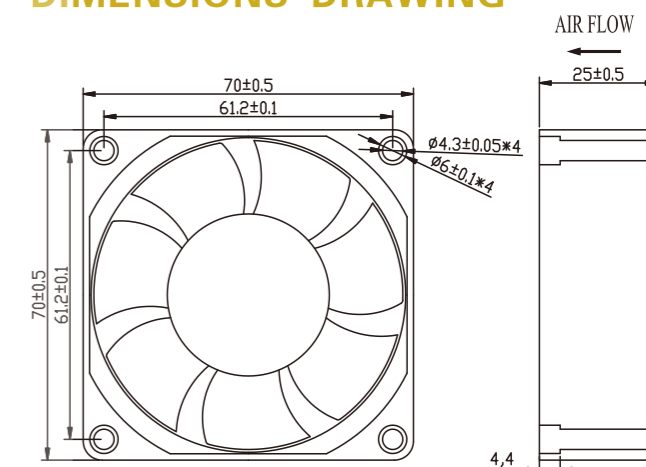

### 7025 EC FAN 70\*70\*25MM SERIES

Material  
UL 1007 AWG # 24 OR Equivalent  
Black Wire:AC

### P & Q CURVE (AT RATED VOLTAGE)

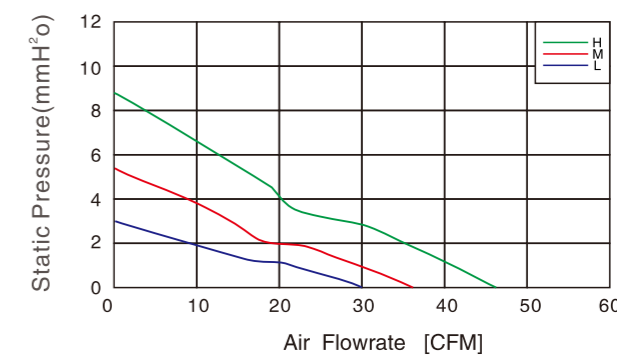

MODEL NO	RATED VOLTAGE V	OPERATING VOLTAGE V	RATED CURRENT A	ACTUAL CURRENT A	RATED POWER W	RATED SPEED RPM (±10%)	MAX. AIR FLOW		MAX.STATIC AIR PRESSURE		NOISE LEVEL dbA
							CMM	CFM	InH2O	mmH2O	
JL7025HA2Y	220	85~265	0.02	4.6	4.4	4800	1.283	45.30	0.330	8.37	44.5
JL7025MA2Y	220	85~265	0.014	3	3.08	3800	1.017	35.90	0.207	5.25	39.5
JL7025LA2Y	220	85~265	0.008	1.8	1.76	3200	0.856	30.24	0.146	3.72	35.7

# 九 龙 电 机

AC Axial Fan  
AC轴流风机

AC All-Metal Axial Fan  
AC全金属轴流风扇

DC Axial Fan  
DC轴流风机

DC Centrifugal Fan  
DC离心风机

EC Axial Fan  
EC轴流风机

EC Centrifugal Fan  
EC离心风机

AC Centrifugal Fan  
AC离心风机

Fan Accessories  
风机配件



JULONG MOTOR  
AC/DC FANS COOLING FANS



本样图仅供参考，具体以规格书为准。  
This sample book is for reference only. Please refer to the specification for details.  
如需特殊电压也可特别提供。本公司保留技术知识产权。  
Special voltage may be provided flexibly according to the requirement. All technical modification rights reserved.

Http://www.xtgygs.cn



DIMENSIONS DRAWING

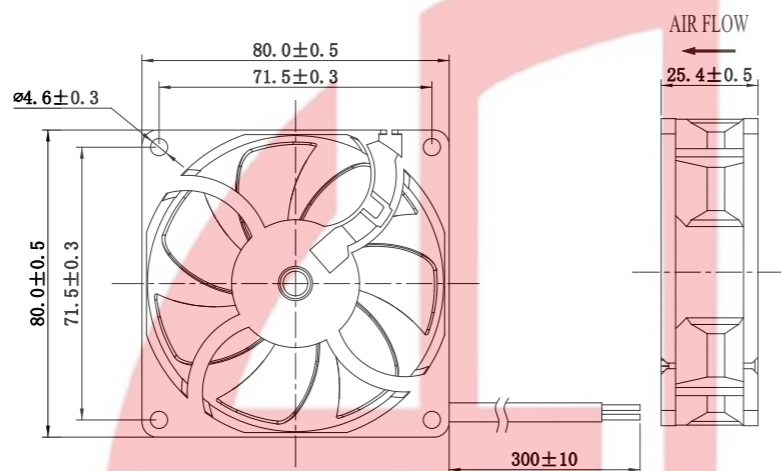

8025 EC FAN  
80\*80\*25MM SERIES

Material  
UL 1007 AWG # 24 OR Equivalent  
Black Wire:AC

P & Q CURVE (AT RATED VOLTAGE)

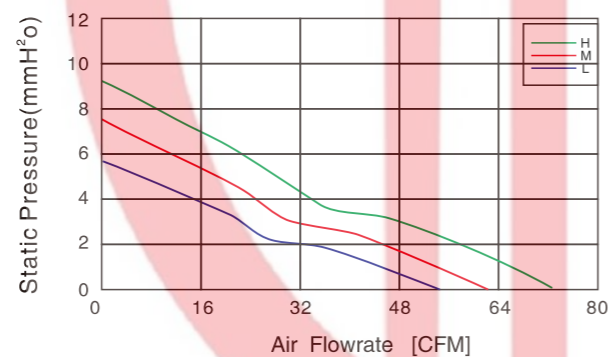

MODEL NO	RATED VOLTAGE ACV	OPERATING VOLTAGE ACV	RATED CURRENT A	RATED POWER W	RATED SPEED RPM (±10%)	MAX. AIR FLOW		MAX.STATIC AIR PRESSURE		NOISE LEVEL dbA
						CMM	CFM	InH <sub>2</sub> O	mmH <sub>2</sub> O	
JL8025HA2Y	220	85~265	0.027	6.0	4500	1.951	68.9	0.382	9.71	42.6
JL8025MA2Y	220	85~265	0.019	4.2	4000	1.736	61.3	0.302	7.67	39.7
JL8025LA2Y	220	85~265	0.013	2.8	3500	1.518	53.6	0.231	5.87	37.1



DIMENSIONS DRAWING

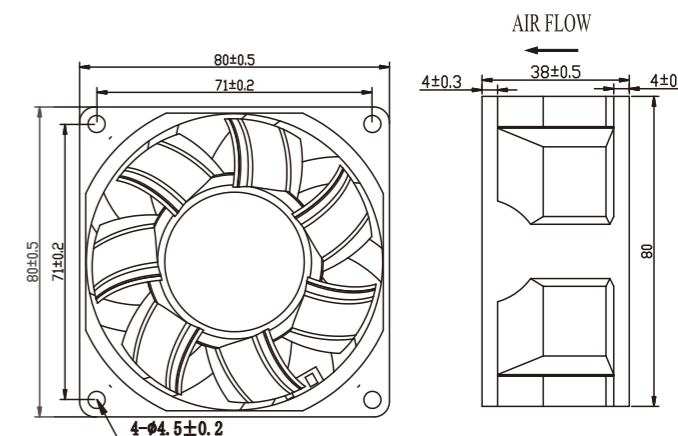

8038 EC FAN  
80\*80\*38MM SERIES

Material  
UL 1007 AWG # 24 OR Equivalent  
Black Wire:AC

P & Q CURVE (AT RATED VOLTAGE)

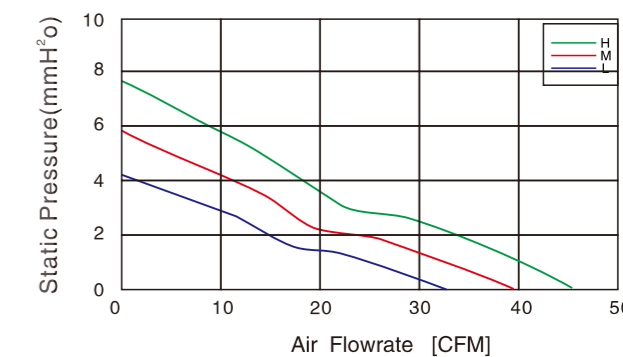

MODEL NO	RATED VOLTAGE ACV	OPERATING VOLTAGE ACV	RATED CURRENT A	RATED POWER W	RATED SPEED RPM (±10%)	MAX. AIR FLOW		MAX.STATIC AIR PRESSURE		NOISE LEVEL dbA
						CMM	CFM	InH <sub>2</sub> O	mmH <sub>2</sub> O	
JL8038HA2Y	220	85~265	0.016	3.6	4000	1.593	56.27	0.398	10.11	44.2
JL8038MA2Y	220	85~265	0.011	2.5	3500	1.394	49.24	0.305	7.74	41.3
JL8038LA2Y	220	85~265	0.007	1.6	3000	1.195	42.20	0.224	5.69	37.9

# 九 龙 电 机

AC Axial Fan  
AC轴流风机

AC All-Metal Axial Fan  
AC全金属轴流风扇

DC Axial Fan  
DC轴流风机

DC Centrifugal Fan  
DC离心风机

EC Axial Fan  
EC轴流风机

EC Centrifugal Fan  
EC离心风机

AC Centrifugal Fan  
AC离心风机

Fan Accessories  
风机配件



JULONG MOTOR  
AC/DC FANS COOLING FANS



本材料均经型式试验合格并符合  
This sample book is for reference only. Please refer to the specification for details.  
如需特殊电压也可根据需要提供。本公司保留技术知识产权。  
special voltage may be provided flexibly according to the requirement. All technical modification rights reserved.

Http://www.xtgygs.cn



DIMENSIONS DRAWING

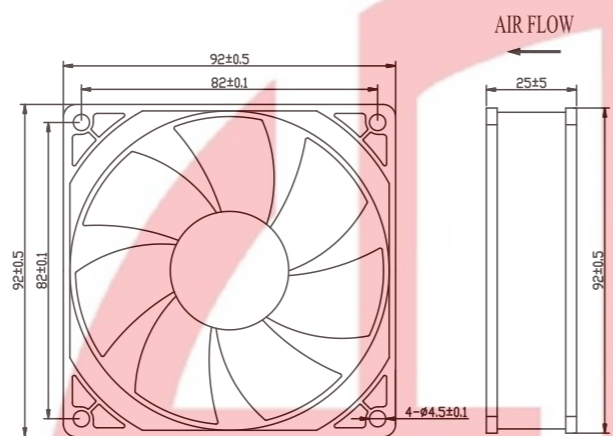

9225 EC FAN  
92\*92\*25MM SERIES

Material  
UL 1007 AWG # 24 OR Equivalent  
Black Wire:AC

P & Q CURVE (AT RATED VOLTAGE)

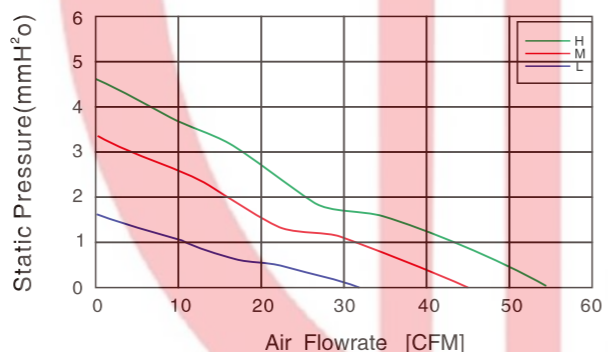

MODEL NO	RATED VOLTAGE ACV	OPERATING VOLTAGE ACV	RATED CURRENT A	RATED POWER W	RATED SPEED RPM (±10%)	MAX. AIR FLOW		MAX. STATIC AIR PRESSURE		NOISE LEVEL dbA
						CMM	CFM	InH <sub>2</sub> O	mmH <sub>2</sub> O	
JL9225HA2Y	220	85~265	0.011	2.5	3000	1.559	55.06	0.179	4.54	37.4
JL9225MA2Y	220	85~265	0.008	1.8	2500	1.299	45.89	0.124	3.15	33.5
JL9225LA2Y	220	85~265	0.005	1.2	1800	0.935	33.03	0.064	1.63	26.3



DIMENSIONS DRAWING

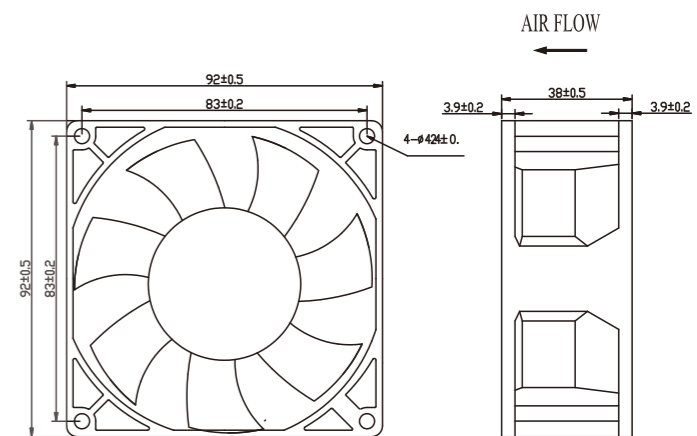

9238 EC FAN  
92\*92\*38MM SERIES

Material  
UL 1007 AWG # 24 OR Equivalent  
Black Wire:AC

P & Q CURVE (AT RATED VOLTAGE)

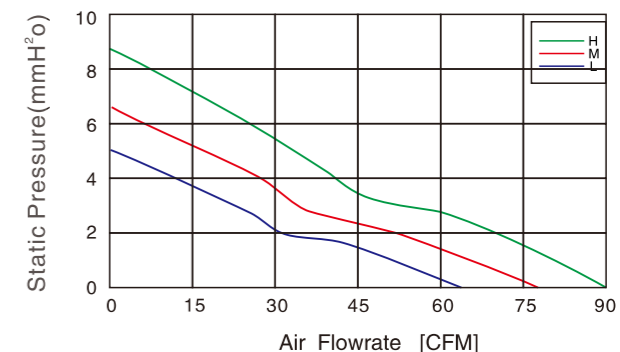

MODEL NO	RATED VOLTAGE ACV	OPERATING VOLTAGE ACV	RATED CURRENT A	RATED POWER W	RATED SPEED RPM (±10%)	MAX. AIR FLOW		MAX. STATIC AIR PRESSURE		NOISE LEVEL dbA
						CMM	CFM	InH <sub>2</sub> O	mmH <sub>2</sub> O	
JL9238HA2Y	220	85~265	0.07	7.0	3600	2.53	89.37	0.341	8.66	47.7
JL9238MA2Y	220	85~265	0.05	5.8	3100	2.18	76.96	0.253	6.42	44.5
JL9238LA2Y	220	85~265	0.03	4.6	2600	1.83	64.55	0.178	4.52	40.6

# 九 龙 电 机

AC Axial Fan  
AC轴流风机

AC All-Metal Axial Fan  
AC全金属轴流风扇

DC Axial Fan  
DC轴流风机

DC Centrifugal Fan  
DC离心风机

EC Axial Fan  
EC轴流风机

EC Centrifugal Fan  
EC离心风机

AC Centrifugal Fan  
AC离心风机

Fan Accessories  
风机配件



JULONG MOTOR  
AC/DC FANS COOLING FANS



本样册仅供参考，具体规格以实物为准。  
This sample book is for reference only. Please refer to the specification for details.  
如需特殊电压也可根据需要提供。本公司保留技术知识产权。  
Special voltage may be provided necessary according to the requirement. All technical modification rights reserved.

Http://www.xtgygs.cn



DIMENSIONS DRAWING

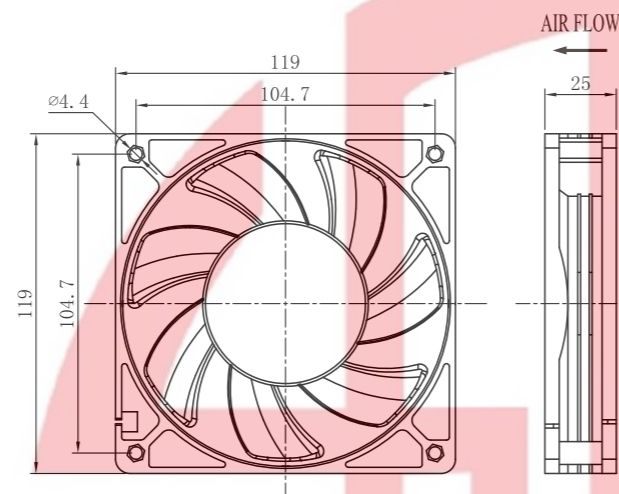

12025 EC FAN  
120\*120\*25MM SERIES

Material  
UL 1007 AWG # 24 OR Equivalent  
Black Wire:AC

P & Q CURVE (AT RATED VOLTAGE)

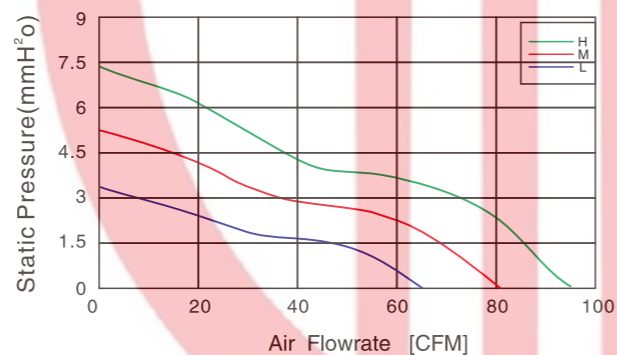

MODEL NO	RATED VOLTAGE ACV	OPERATING VOLTAGE ACV	RATED CURRENT A	RATED POWER W	RATED SPEED RPM (±10%)	MAX. AIR FLOW		MAX.STATIC AIR PRESSURE		NOISE LEVEL dbA
						CMM	CFM	InH2O	mmH2O	
JL12025HA2Y	220	85~265	0.1	8.5	3000	2.71	95.80	0.280	7.11	43.1
JL9238MA2Y	220	85~265	0.03	6.4	2500	2.26	79.80	0.194	4.94	39.1
JL12025MA2Y	220	85~265	0.015	3.28	2000	1.81	63.80	0.124	3.16	34.2



DIMENSIONS DRAWING

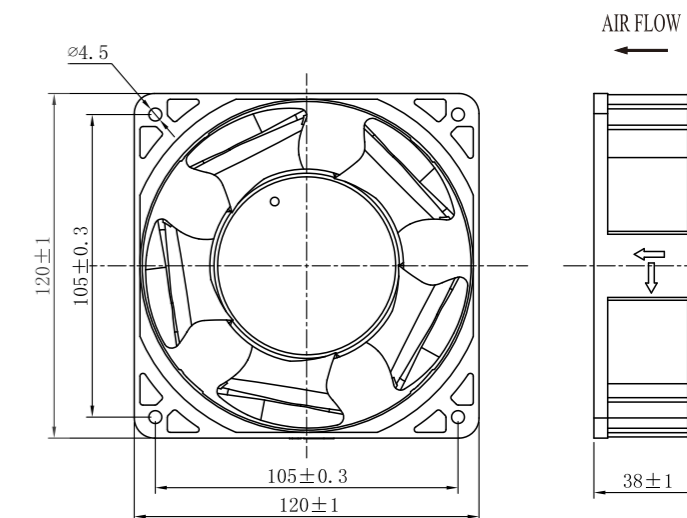

12038 EC FAN  
120\*120\*38MM SERIES

Material  
UL 1007 AWG # 24 OR Equivalent  
Black Wire:AC

P & Q CURVE (AT RATED VOLTAGE)

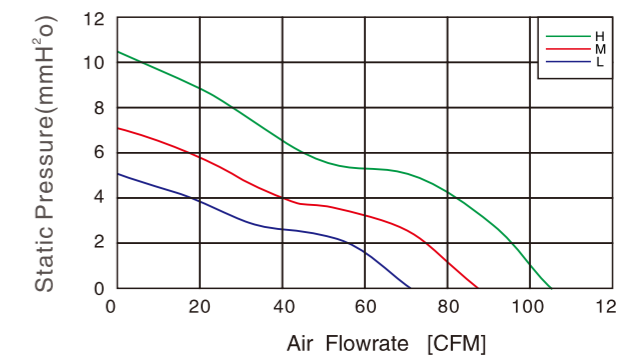

MODEL NO	RATED VOLTAGE ACV	OPERATING VOLTAGE ACV	RATED CURRENT A	RATED POWER W	RATED SPEED RPM (±10%)	MAX. AIR FLOW		MAX.STATIC AIR PRESSURE		NOISE LEVEL dbA
						CMM	CFM	InH2O	mmH2O	
JL12025HA2Y	220	85~265	0.04	8.0	3100	2.97	104.8	0.407	10.35	47.7
JL12025MA2Y	220	85~265	0.023	5.0	2600	2.49	87.90	0.287	7.28	43.7
JL12025LA2Y	220	85~265	0.013	2.9	2200	2.11	74.40	0.205	5.21	40.1

# 九 龙 电 机

AC Axial Fan  
AC轴流风机

AC All-Metal Axial Fan  
AC全金属轴流风扇

DC Axial Fan  
DC轴流风机

DC Centrifugal Fan  
DC离心风机

EC Axial Fan  
EC轴流风机

EC Centrifugal Fan  
EC离心风机

AC Centrifugal Fan  
AC离心风机

Fan Accessories  
风机配件



JULONG MOTOR  
AC/DC FANS COOLING FANS



本样册仅供参考，具体以规格书为准。  
This sample book is for reference only. Please refer to the specification for details.  
如需特殊电压也可根据规格书提供。本公司保留技术知识产权。  
Special voltage may be provided flexibly according to the enquiry. All rights reserved.

Http://www.xtgygs.cn



DIMENSIONS DRAWING

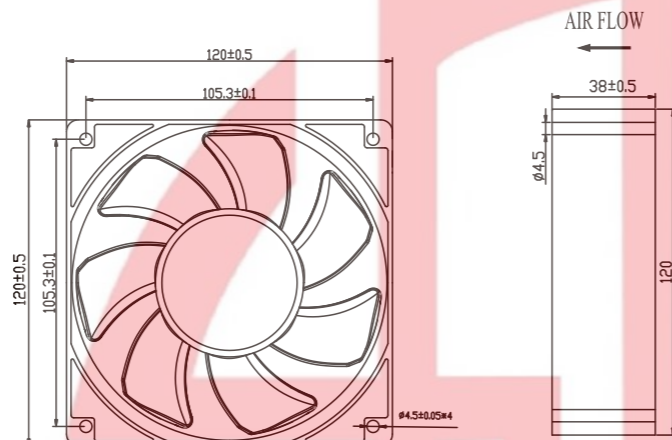

12038 EC FAN  
120 \* 120 \* 38MM SERIES

Material  
UL 1007 AWG # 24 OR Equivalent  
Black Wire:AC

P & Q CURVE (AT RATED VOLTAGE)

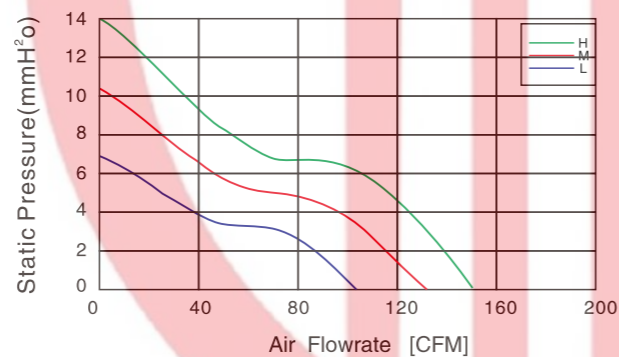

MODEL NO	RATED VOLTAGE ACV	OPERATING VOLTAGE ACV	RATED CURRENT A	RATED POWER W	RATED SPEED RPM (±10%)	MAX. AIR FLOW		MAX.STATIC AIR PRESSURE		NOISE LEVEL dbA
						CMM	CFM	InH2O	mmH2O	
JL12038HA2Y	220	85~265	0.15	15	3400	3.98	104.4	0.480	12.2	47.8
JL12038MA2Y	220	85~265	0.04	8.0	3100	3.63	128.1	0.399	10.14	46
JL12038LA2Y	220	85~265	0.02	4.6	2500	2.92	103.2	0.260	6.61	41.1



DIMENSIONS DRAWING

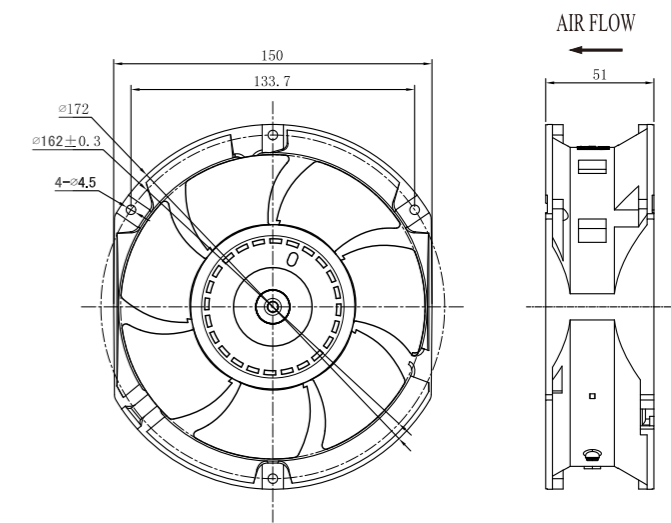

17251 EC FAN  
172 \* 150 \* 51MM SERIES

Material  
UL 1007 AWG # 24 OR Equivalent  
Black Wire:AC

P & Q CURVE (AT RATED VOLTAGE)

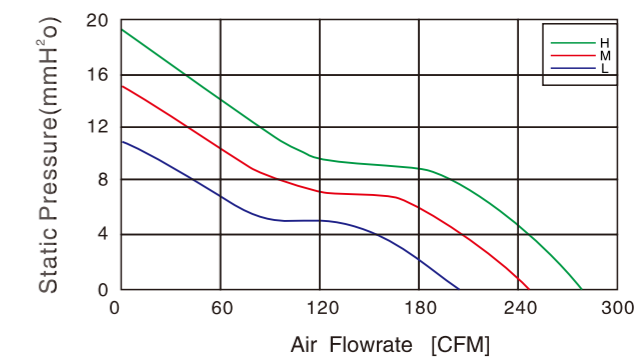

MODEL NO	RATED VOLTAGE ACV	OPERATING VOLTAGE ACV	RATED CURRENT A	RATED POWER W	RATED SPEED RPM (±10%)	MAX. AIR FLOW		MAX.STATIC AIR PRESSURE		NOISE LEVEL dbA
						CMM	CFM	InH2O	mmH2O	
JL17251HA2B	220	85~265	0.12	25	3500	7.72	272.5	0.747	18.97	58
JL17251MA2B	220	85~265	0.09	19	3100	6.83	241.4	0.586	14.88	55.4
JL17251LA2B	220	85~265	0.06	13	2600	5.73	202.4	0.412	10.47	51.5

# 九 龙 电 机

AC Axial Fan  
AC轴流风机

AC All-Metal Axial Fan  
AC全金属轴流风扇

DC Axial Fan  
DC轴流风机

DC Centrifugal Fan  
DC离心风机

EC Axial Fan  
EC轴流风机

EC Centrifugal Fan  
EC离心风机

AC Centrifugal Fan  
AC离心风机

Fan Accessories  
风机配件



JULONG MOTOR  
AC/DC FANS COOLING FANS

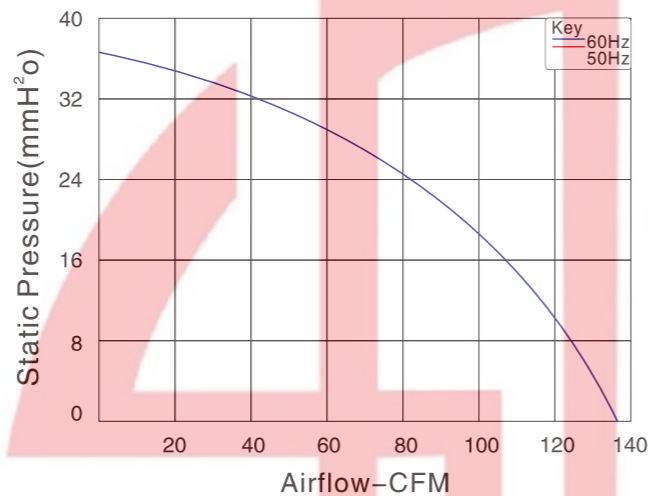

尺寸 Size: Ø108mmX62mm  
风量 Airflow: 136.2CFM  
噪音 Noise: 63.2dB(A)  
风叶 Impeller Material: Metal  
工作方式 Operation mode: S1  
温度范围 Operating Temperature: -10°C~+65°C  
防护等级 Type of protection: IP44  
绝缘等级 Insulation class: "B"

产品型号 Model	电压 Voltage VAC	频率 Freq. Hz	电流 Current A	功率 Power W	转速 Speed RPM	风量 Air Flow CFM	静压 Static Pressure mmH <sub>2</sub> O	噪音 Noise dB(A)
YED108AGA2-A01-W	230	50/60	0.26	57	2800	136.2	37.9	63.2

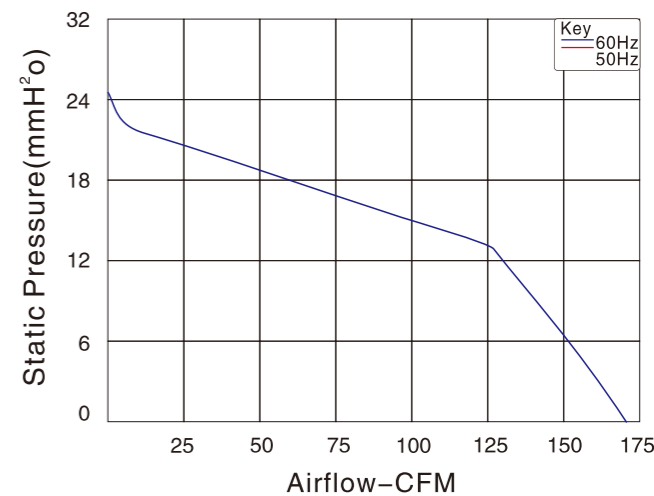

尺寸 Size: Ø120mmX62mm  
风量 Airflow: 172CFM  
噪音 Noise: 57.8dB(A)  
风叶 Impeller Material: Metal  
工作方式 Operation mode: S1  
温度范围 Operating Temperature: -10°C~+65°C  
防护等级 Type of protection: IP44  
绝缘等级 Insulation class: "B"

产品型号 Model	电压 Voltage VAC	频率 Freq. Hz	电流 Current A	功率 Power W	转速 Speed RPM	风量 Air Flow CFM	静压 Static Pressure mmH <sub>2</sub> O	噪音 Noise dB(A)
YED120BGA2-A01-W	230	50/60	0.25	54	2400	172	24.5	57.8

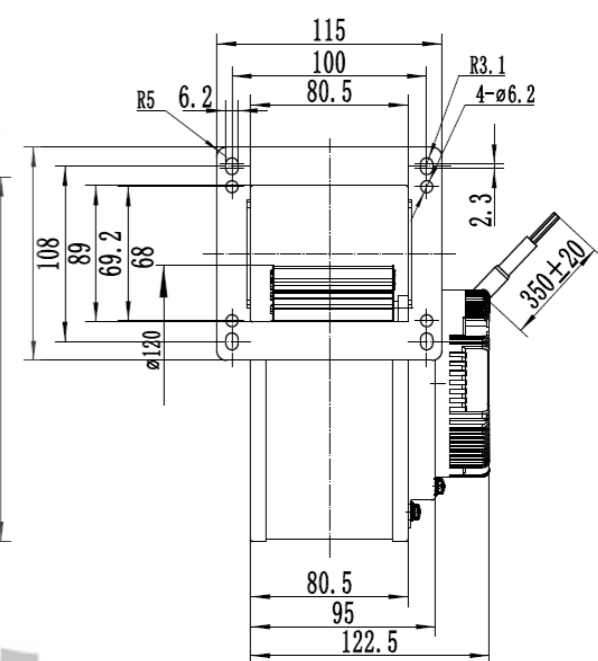
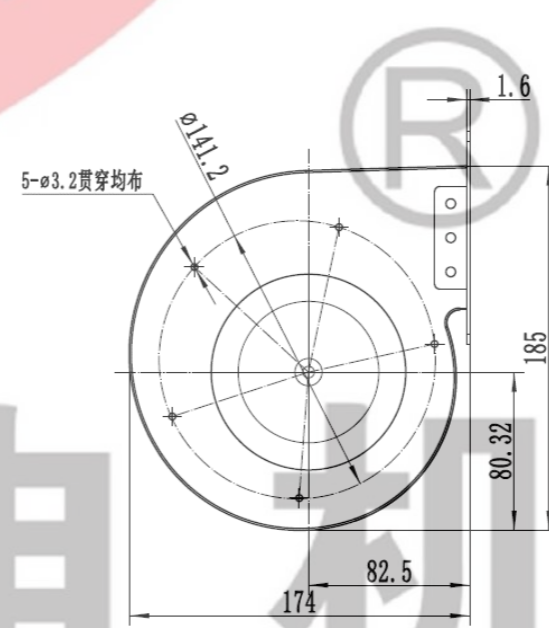
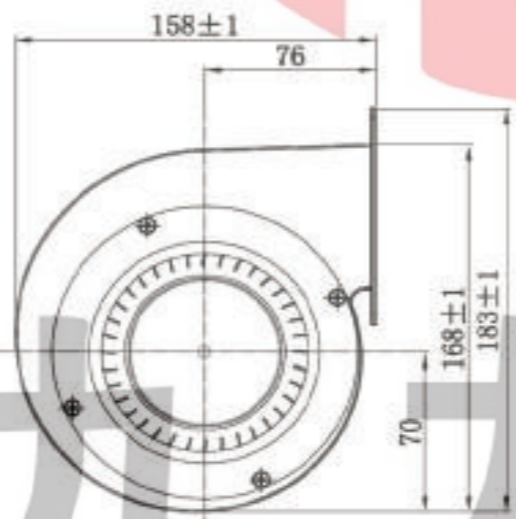
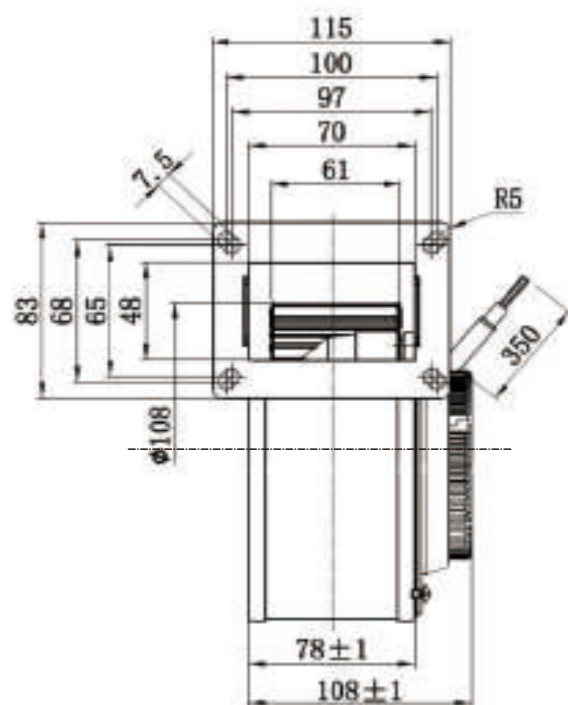



JULONG MOTOR  
AC/DC FANS COOLING FANS

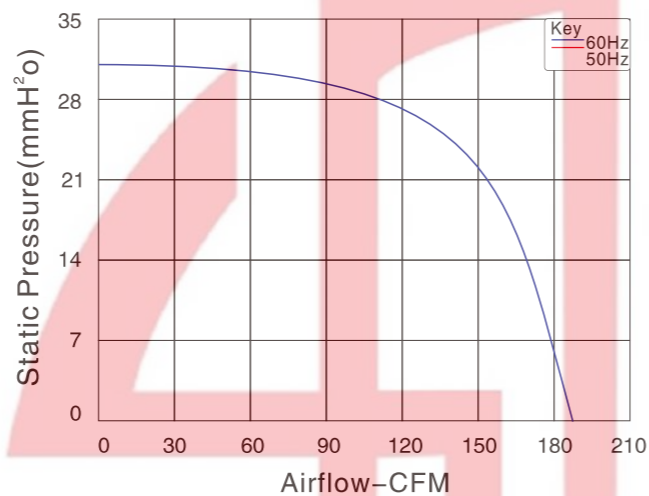

尺寸 Size: Ø133mmX50mm  
 风量 Airflow: 183.6CFM  
 噪音 Noise: 60dB(A)  
 风叶 Impeller Material: Metal  
 工作方式 Operation mode: S1  
 温度范围 Operating Temperature: -10°C~+65°C  
 防护等级 Type of protection: IP44  
 绝缘等级 Insulation class: "B"

产品型号 Model	电压 Voltage VAC	频率 Freq. Hz	电流 Current A	功率 Power W	转速 Speed RPM	风量 Air Flow CFM	静压 Static Pressure mmH <sub>2</sub> O	噪音 Noise dB(A)
YED133AGA2-A01-W	230	50/60	0.4	87	2400	183.6	31.2	60

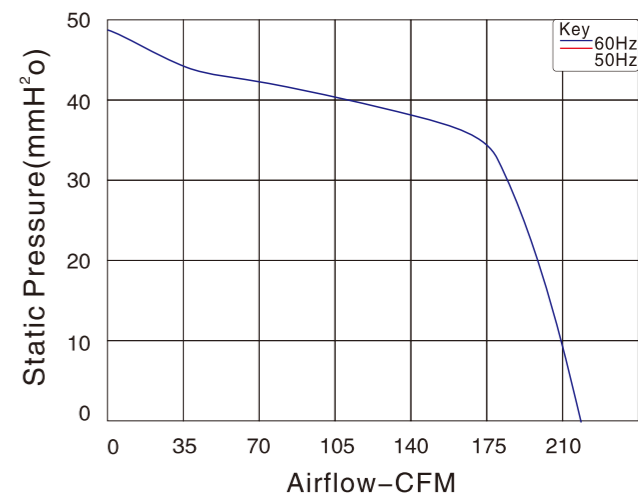
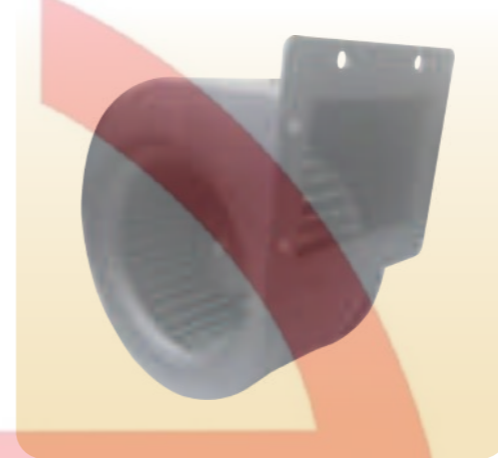
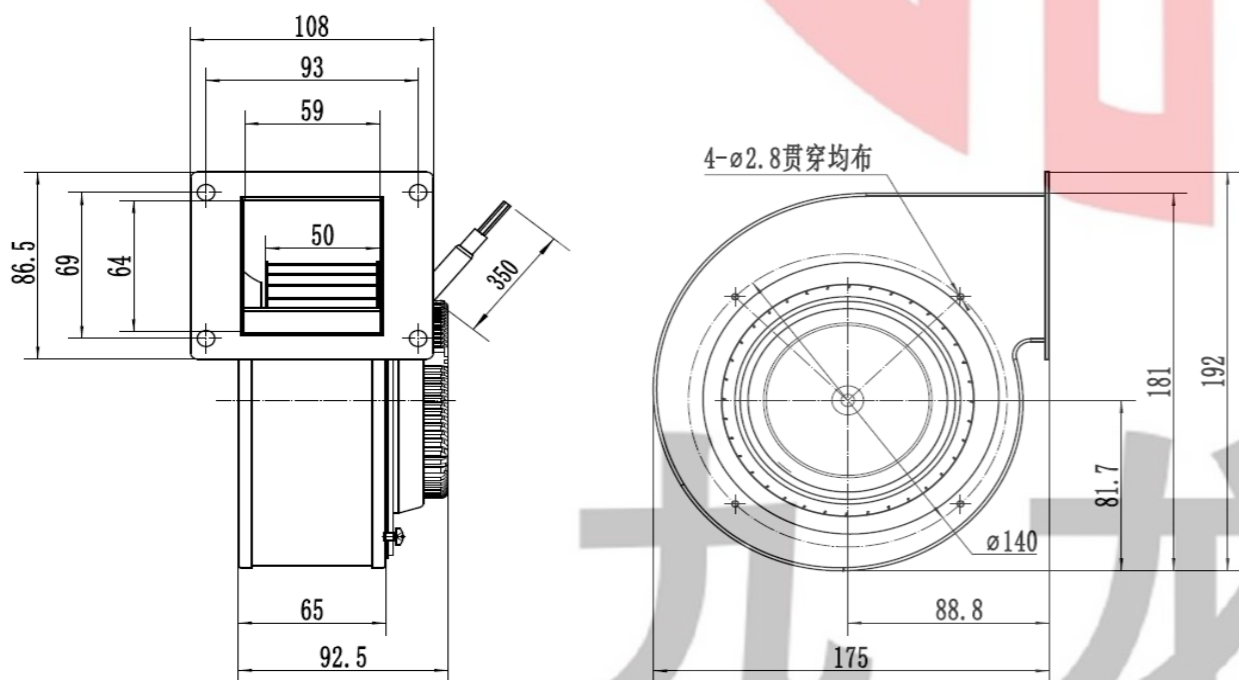

尺寸 Size: Ø133mmX74mm  
 风量 Airflow: 224CFM  
 噪音 Noise: 58.2dB(A)  
 风叶 Impeller Material: Metal  
 工作方式 Operation mode: S1  
 温度范围 Operating Temperature: -10°C~+65°C  
 防护等级 Type of protection: IP44  
 绝缘等级 Insulation class: "B"

产品型号 Model	电压 Voltage VAC	频率 Freq. Hz	电流 Current A	功率 Power W	转速 Speed RPM	风量 Air Flow CFM	静压 Static Pressure mmH <sub>2</sub> O	噪音 Noise dB(A)
YED133BGA2-A01-W	230	50/60	0.37	82	2200	224	48	58.2

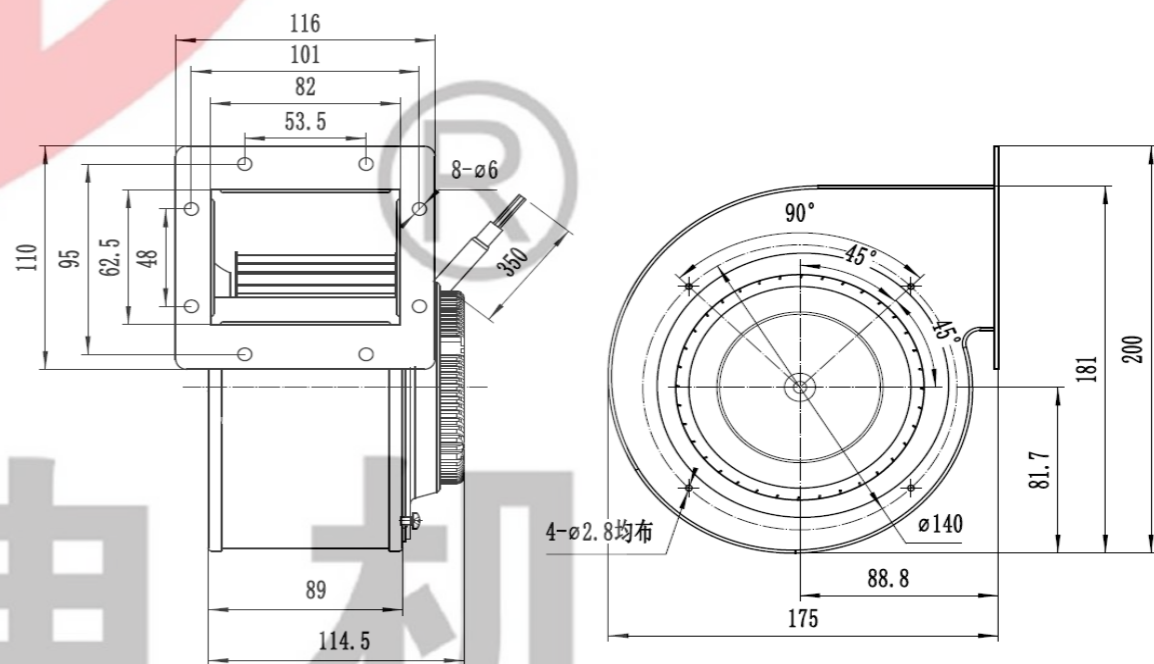

本样图仅供参考，具体以实物为准。  
 This sample book is for reference only. Please refer to the specification for details.  
 如需特殊电压也可根据需求提供。本公司保留技术知识产权。  
 special voltage may be provided flexibly according to the enquiry. All technical modification rights reserved.

Http://www.xtgygs.cn



JIULONG MOTOR  
AC/DC FANS COOLING FANS



尺寸 Size:  $\varnothing 133\text{mm} \times 74\text{mm}$   
 风量 Airflow: 224CFM  
 噪音 Noise: 58.2dB(A)  
 风叶 Impeller Material: Metal  
 工作方式 Operation mode: S1  
 温度范围 Operating Temperature:  $-10^{\circ}\text{C} \sim +65^{\circ}\text{C}$   
 防护等级 Type of protection: IP44  
 绝缘等级 Insulation class: "B"

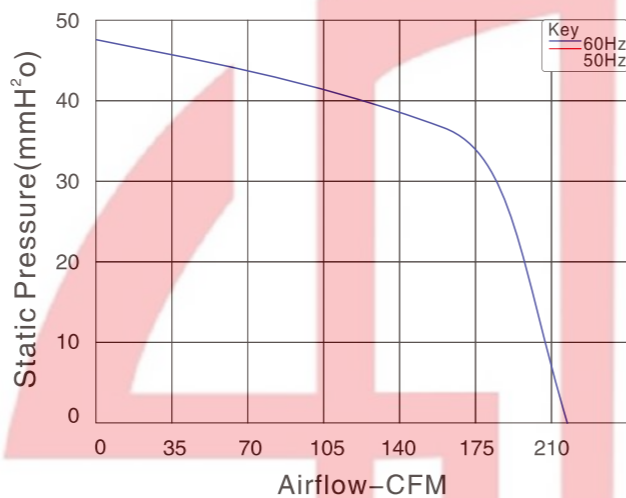

尺寸 Size:  $\varnothing 140\text{mm} \times 62\text{mm}$   
 风量 Airflow: 306CFM  
 噪音 Noise: 64dB(A)  
 风叶 Impeller Material: PA66  
 工作方式 Operation mode: S1  
 温度范围 Operating Temperature:  $-10^{\circ}\text{C} \sim +65^{\circ}\text{C}$   
 防护等级 Type of protection: IP44  
 绝缘等级 Insulation class: "B"

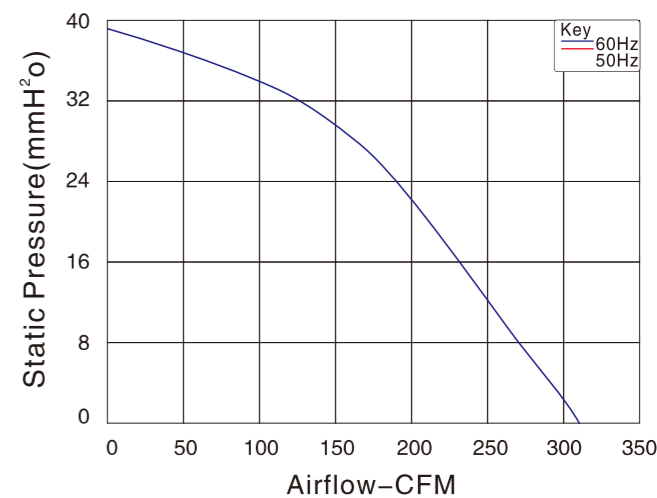

产品型号 Model	电压 Voltage VAC	频率 Freq. Hz	电流 Current A	功率 Power W	转速 Speed RPM	风量 Air Flow CFM	静压 Static Pressure mmH <sub>2</sub> O	噪音 Noise dB(A)
YED133CGA2-A01-W	230	50/60	0.37	82	2200	224	48	58.2

产品型号 Model	电压 Voltage VAC	频率 Freq. Hz	电流 Current A	功率 Power W	转速 Speed RPM	风量 Air Flow CFM	静压 Static Pressure mmH <sub>2</sub> O	噪音 Noise dB(A)
YED140BGA2-A01-W	230	50/60	0.68	108	2000	306	39.3	64

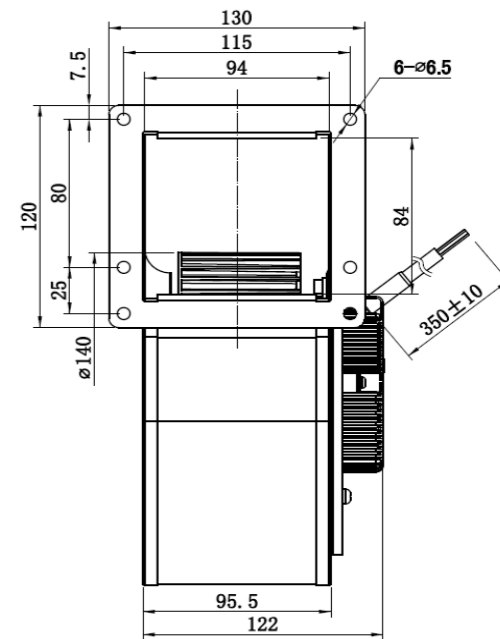
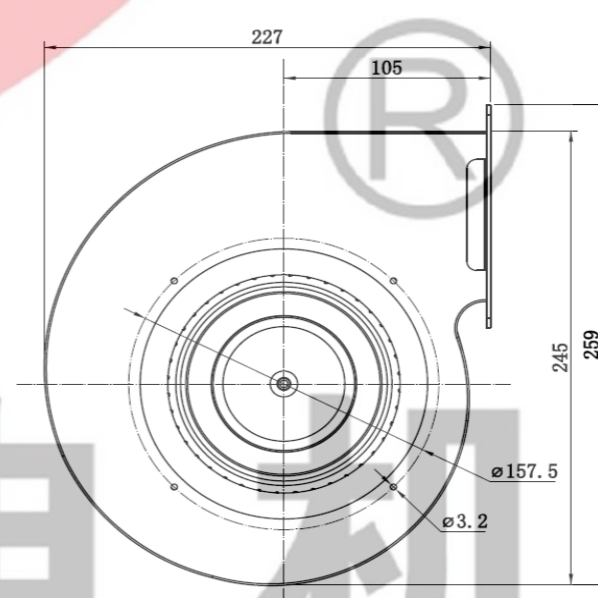
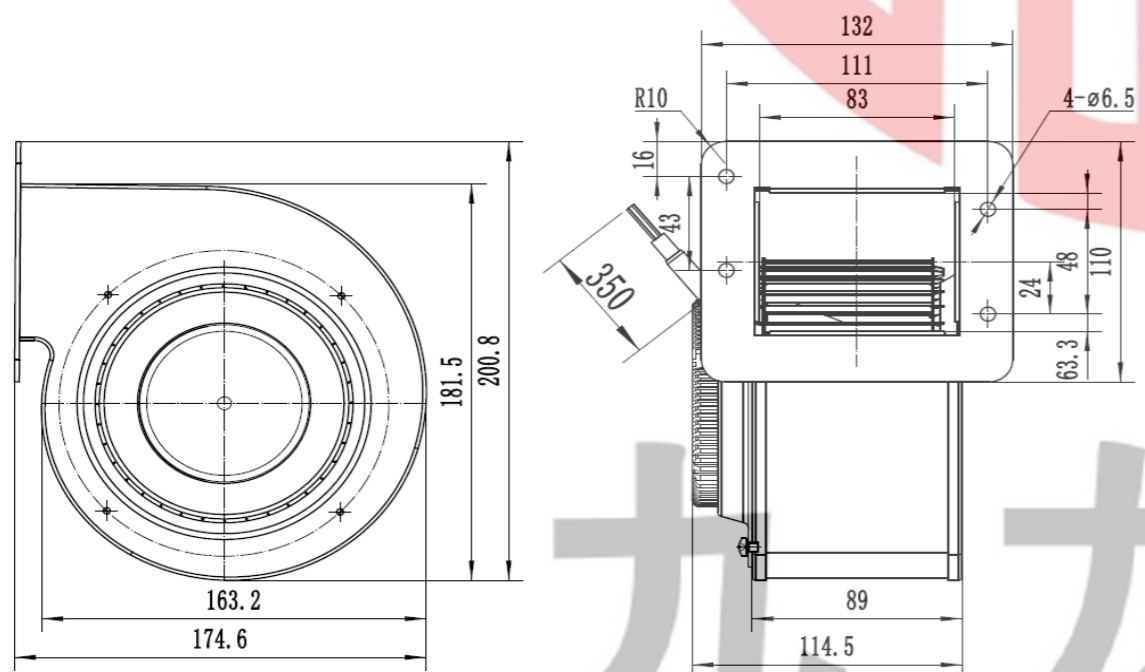

本样机仅供参考，具体以实物为准。  
 This sample book is for reference only. Please refer to the specification for details.  
 如需特殊电压也可根据需求提供。本公司保留技术知识产权。  
 special voltage may be provided flexibly according to the query. All rights reserved.

Http://www.xtgygs.cn



JULONG MOTOR  
AC/DC FANS COOLING FANS

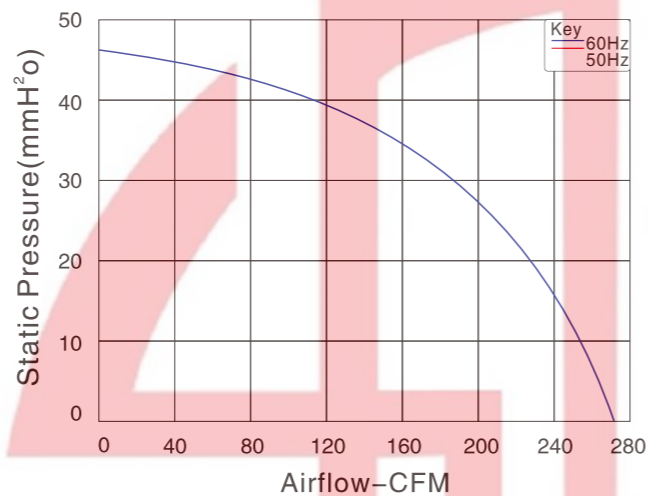

尺寸 Size: Ø150mmX72mm  
 风量 Airflow: 275CFM  
 噪音 Noise: 68.1dB(A)  
 风叶 Impeller Material: Metal  
 工作方式 Operation mode: S1  
 温度范围 Operating Temperature: -10°C~+65°C  
 防护等级 Type of protection: IP44  
 绝缘等级 Insulation class: "B"

产品型号 Model	电压 Voltage VAC	频率 Freq. Hz	电流 Current A	功率 Power W	转速 Speed RPM	风量 Air Flow CFM	静压 Static Pressure mmH <sub>2</sub> O	噪音 Noise dB(A)
YED150AGA2-A01-W	230	50/60	0.54	120	2200	275	47.1	68.1

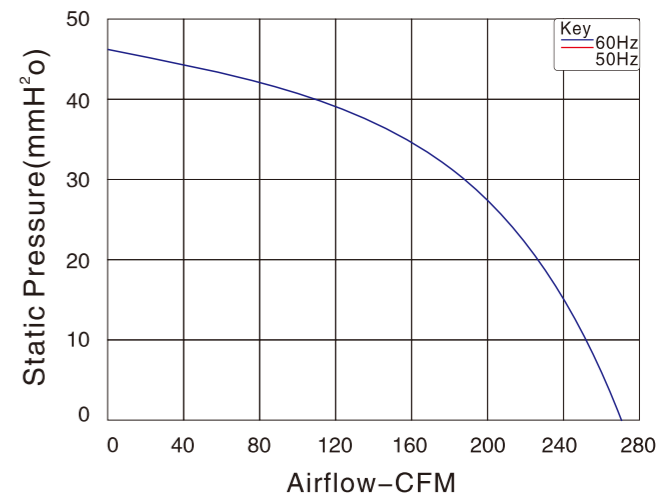

尺寸 Size: Ø150mmX72mm  
 风量 Airflow: 275CFM  
 噪音 Noise: 68.1dB(A)  
 风叶 Impeller Material: Metal  
 工作方式 Operation mode: S1  
 温度范围 Operating Temperature: -10°C~+65°C  
 防护等级 Type of protection: IP44  
 绝缘等级 Insulation class: "B"

产品型号 Model	电压 Voltage VAC	频率 Freq. Hz	电流 Current A	功率 Power W	转速 Speed RPM	风量 Air Flow CFM	静压 Static Pressure mmH <sub>2</sub> O	噪音 Noise dB(A)
YED150BGA2-A01-W	230	50/60	0.54	120	2200	275	47.1	68.1

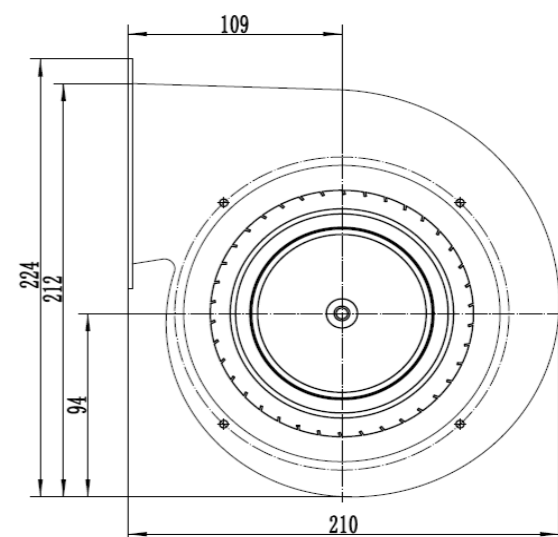
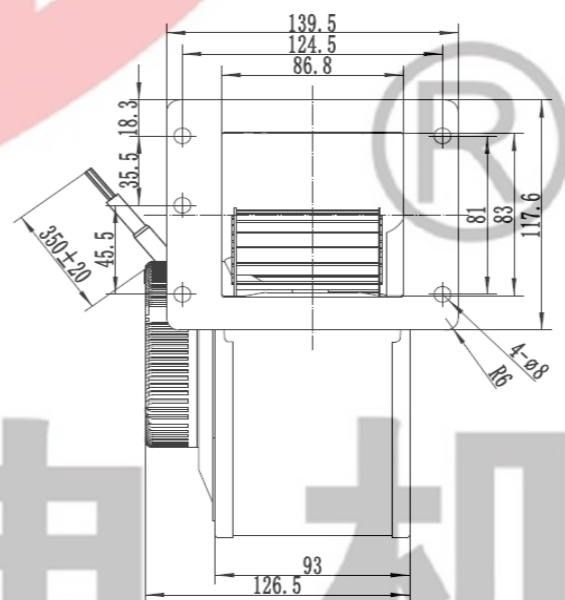
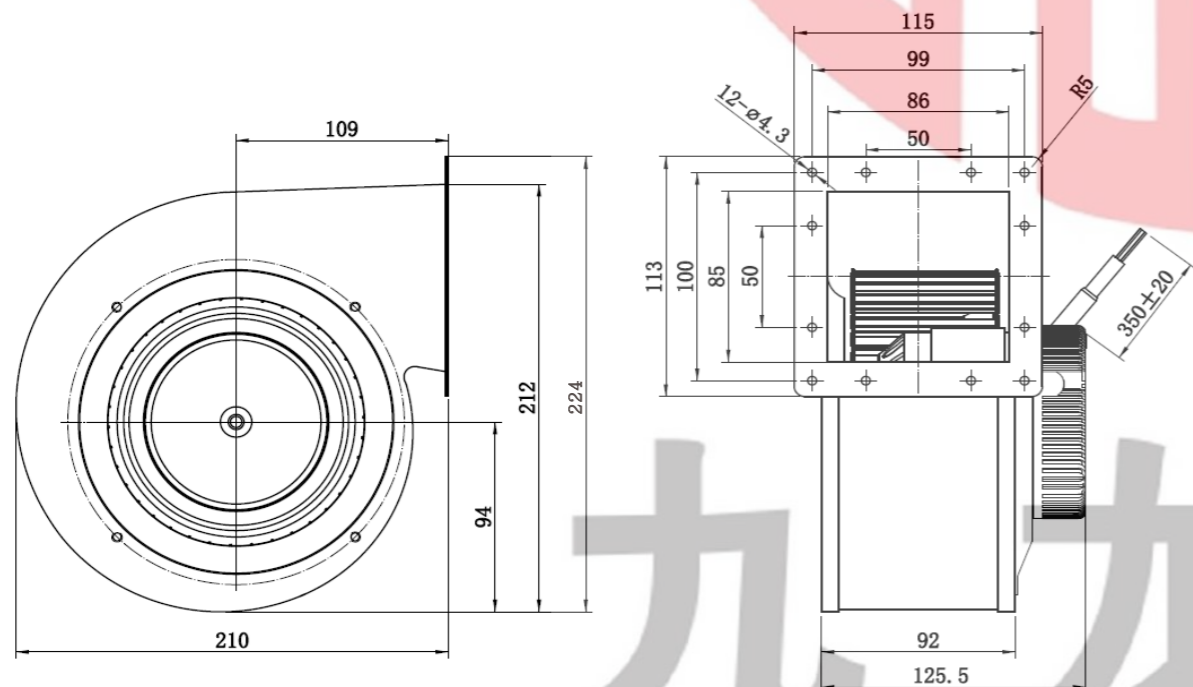

本样机仅供参考，具体以规格书为准。  
 This sample book is for reference only. Please refer to the specification for details.  
 如需特殊电压也可根据需求提供。本公司保留技术知识产权。  
 special voltage may be provided flexibly according to the enquiry. All technical modification rights reserved.

Http://www.xtgygs.cn



JULONG MOTOR  
AC/DC FANS COOLING FANS



本样图仅供参考，具体以实物为准。  
This sample book is for reference only. Please refer to the specification for details.  
如需特殊电压也可根据需求提供。本公司保留技术知识产权。  
Special voltage may be provided flexibly according to the requirement. All technical modification rights reserved.

Http://www.xtgygs.cn

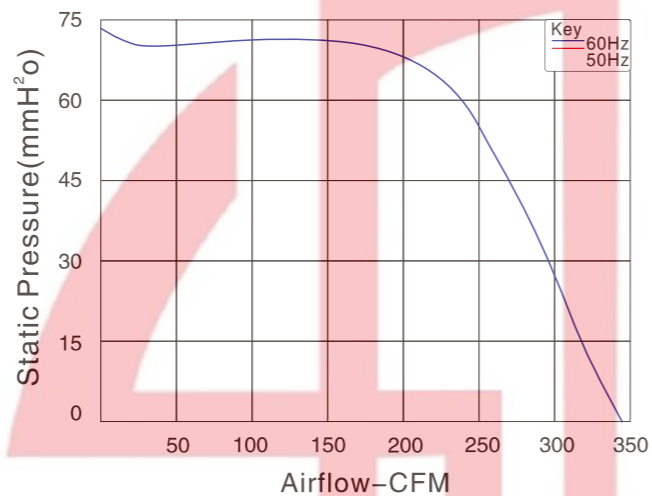

尺寸 Size: Ø160mmX72mmmm  
风量 Airflow: 348.7CFM  
噪音 Noise: 63.5dB(A)  
风叶 Impeller Material: Metal  
工作方式 Operation mode: S1  
温度范围 Operating Temperature: -10°C~+65°C  
防护等级 Type of protection: IP44  
绝缘等级 Insulation class: "B"

产品型号 Model	电压 Voltage VAC	频率 Freq. Hz	电流 Current A	功率 Power W	转速 Speed RPM	风量 Air Flow CFM	静压 Static Pressure mmH <sub>2</sub> O	噪音 Noise dB(A)
YED160AGA2-A01-W	230	50/60	0.54	120	1950	348.7	59.5	63.5

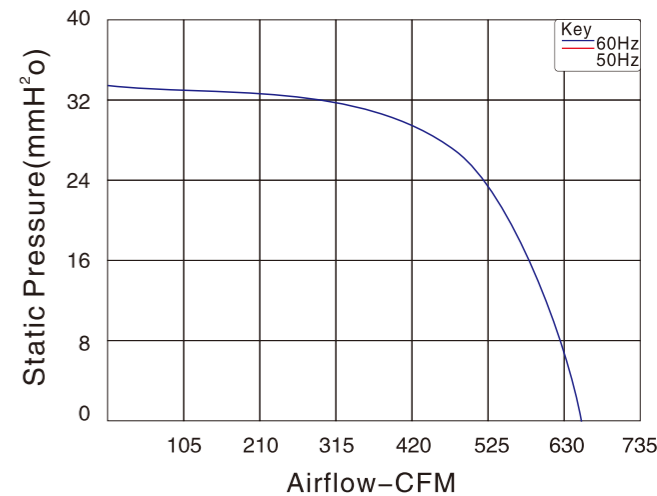
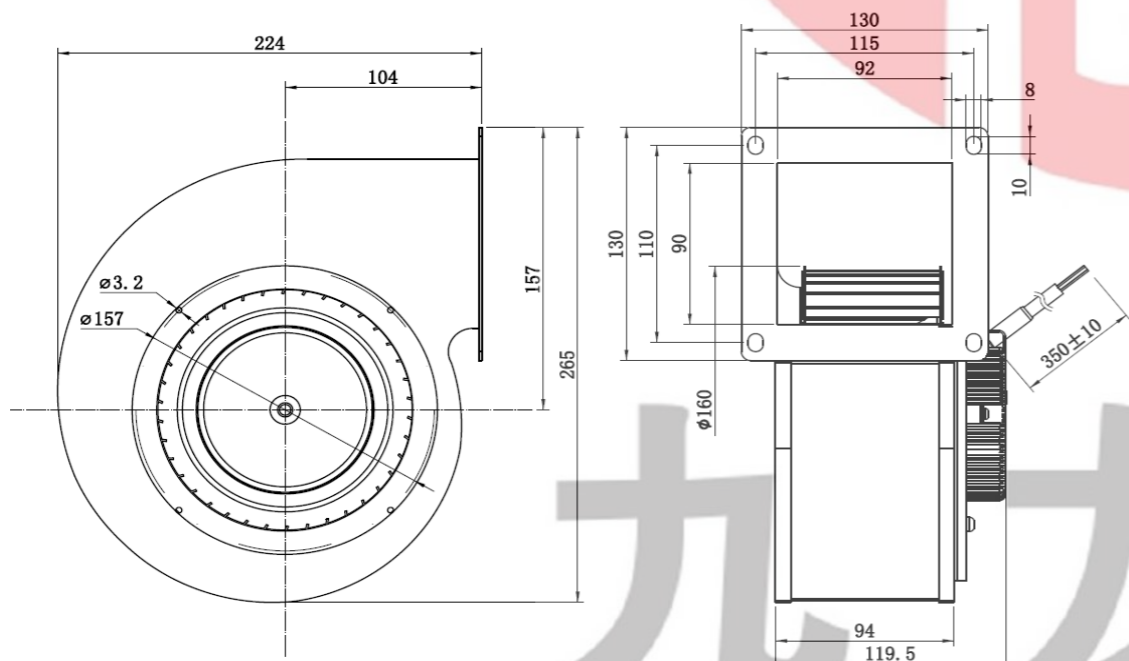

尺寸 Size: Ø180mmX90mm  
风量 Airflow: 645.2CFM  
噪音 Noise: 67.8dB(A)  
风叶 Impeller Material: Metal  
工作方式 Operation mode: S1  
温度范围 Operating Temperature: -10°C~+65°C  
防护等级 Type of protection: IP44  
绝缘等级 Insulation class: "B"

产品型号 Model	电压 Voltage VAC	频率 Freq. Hz	电流 Current A	功率 Power W	转速 Speed RPM	风量 Air Flow CFM	静压 Static Pressure mmH <sub>2</sub> O	噪音 Noise dB(A)
YED180AHA2-A01-W	230	50/60	0.86	190	1650	645.2	33	67.8

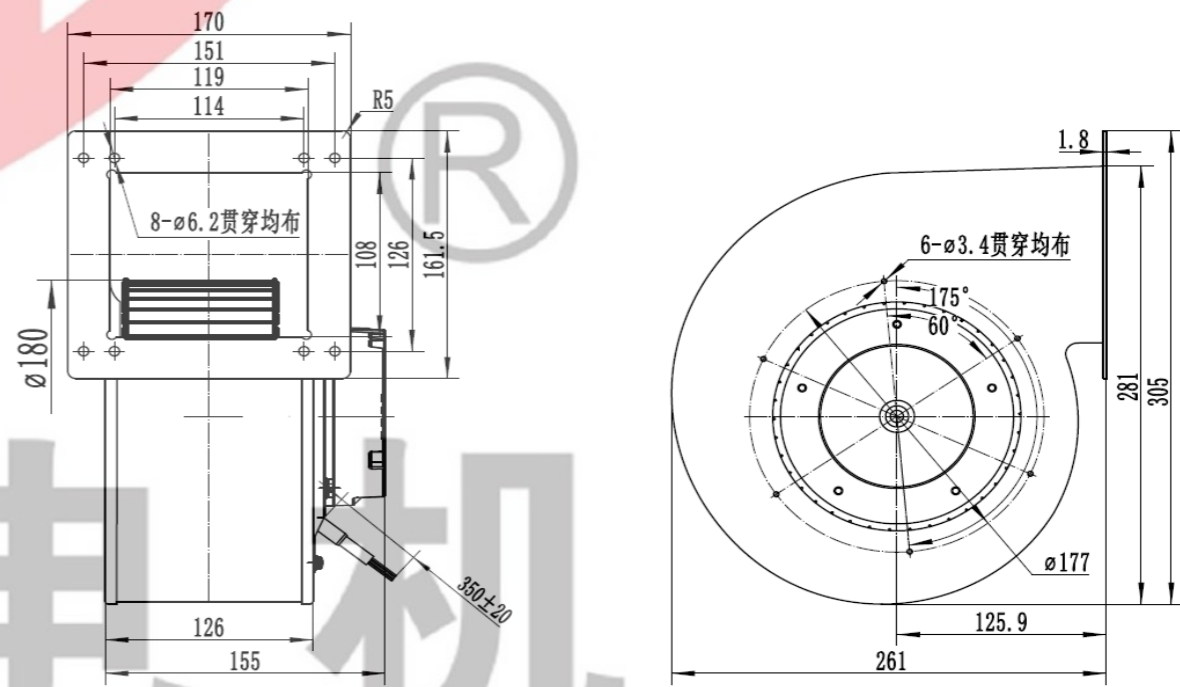

九龙电机

AC Axial Fan  
AC轴流风机

AC All-Metal Axial Fan  
AC全金属轴流风扇

DC Axial Fan  
DC轴流风机

DC Centrifugal Fan  
DC离心风机

EC Axial Fan  
EC轴流风机

EC Centrifugal Fan  
EC离心风机

AC Centrifugal Fan  
AC离心风机

Fan Accessories  
风机配件

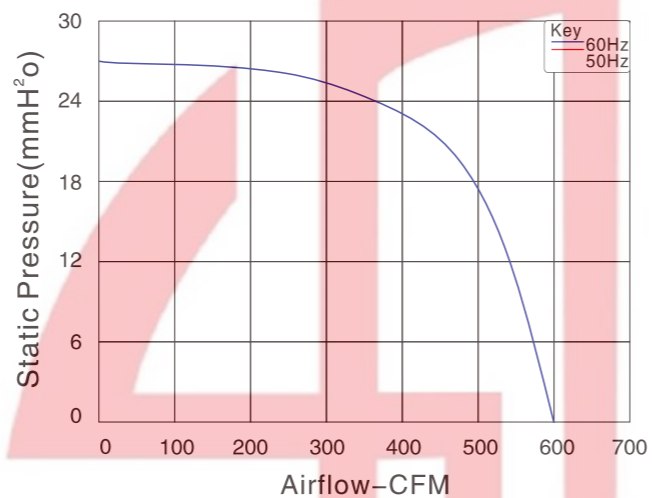

尺寸 Size: Ø200mmX54mm  
风量 Airflow: 589CFM  
噪音 Noise: 58dB(A)  
风叶 Impeller Material: Metal  
工作方式 Operation mode: S1  
温度范围 Operating Temperature: -10°C~+65°C  
防护等级 Type of protection: IP44  
绝缘等级 Insulation class: "B"

产品型号 Model	电压 Voltage VAC	频率 Freq. Hz	电流 Current A	功率 Power W	转速 Speed RPM	风量 Air Flow CFM	静压 Static Pressure mmH <sub>2</sub> O	噪音 Noise dB(A)
YED200AHA2-A01-W	230	50/60	0.55	120	1300	589	27	58

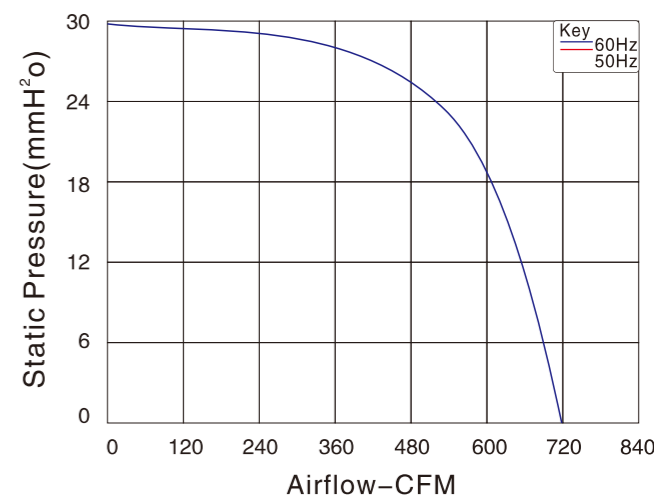

尺寸 Size: Ø200mmX81mm  
风量 Airflow: 719CFM  
噪音 Noise: 53dB(A)  
风叶 Impeller Material: Metal  
工作方式 Operation mode: S1  
温度范围 Operating Temperature: -10°C~+65°C  
防护等级 Type of protection: IP44  
绝缘等级 Insulation class: "B"

产品型号 Model	电压 Voltage VAC	频率 Freq. Hz	电流 Current A	功率 Power W	转速 Speed RPM	风量 Air Flow CFM	静压 Static Pressure mmH <sub>2</sub> O	噪音 Noise dB(A)
YED200BHA2-A01-W	230	50/60	0.66	145	1400	719	29.5	53

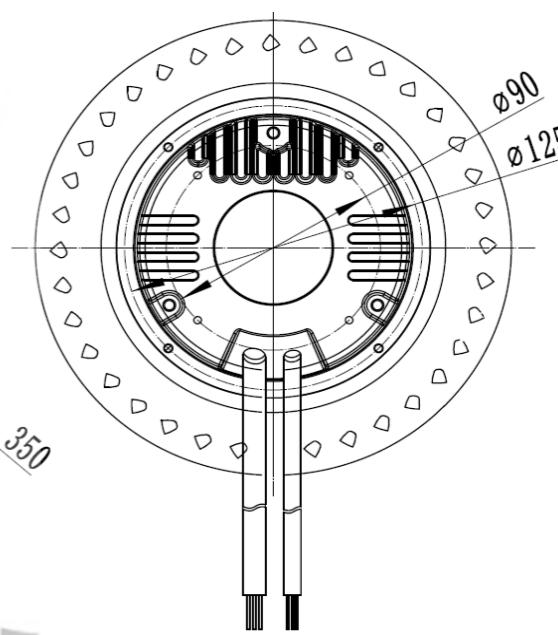
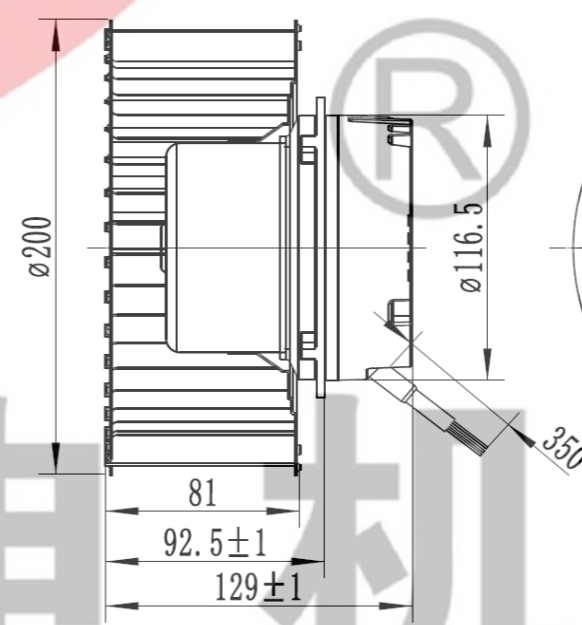
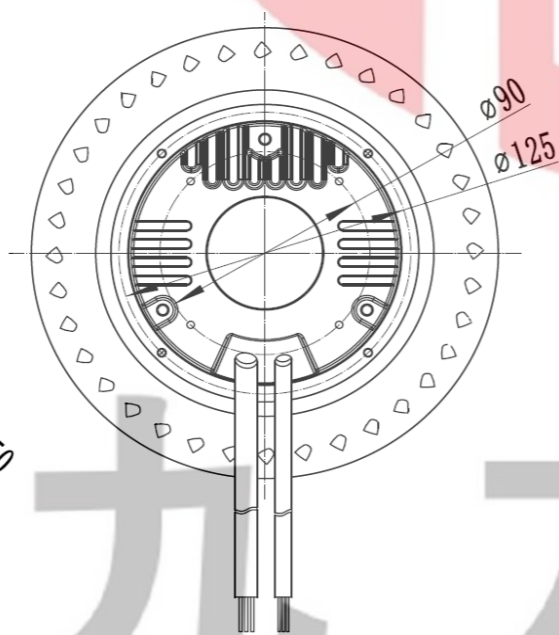
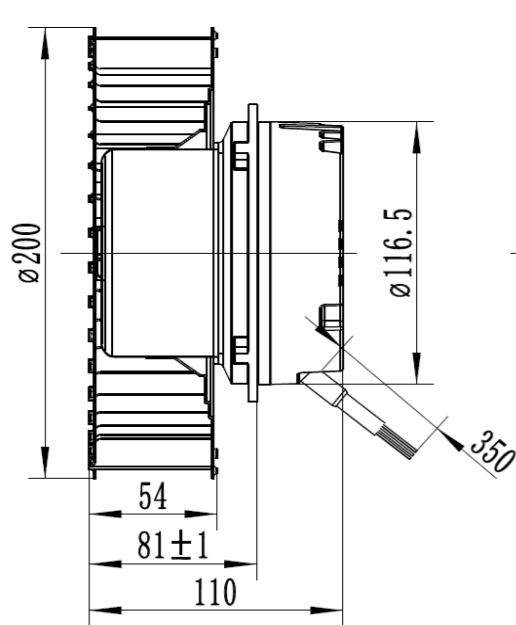

九 龙 电 机



JIULONG MOTOR  
AC/DC FANS COOLING FANS



UL  
E248719



本样机仅供参考，具体以规格书为准。  
This sample book is for reference only. Please refer to the specification for details.  
如需特殊电压也可特别定制提供。本公司保留技术知识产权。  
Special voltage may be provided flexibly according to the enquiry. All technical modification rights reserved.

Http://www.xtgygs.cn

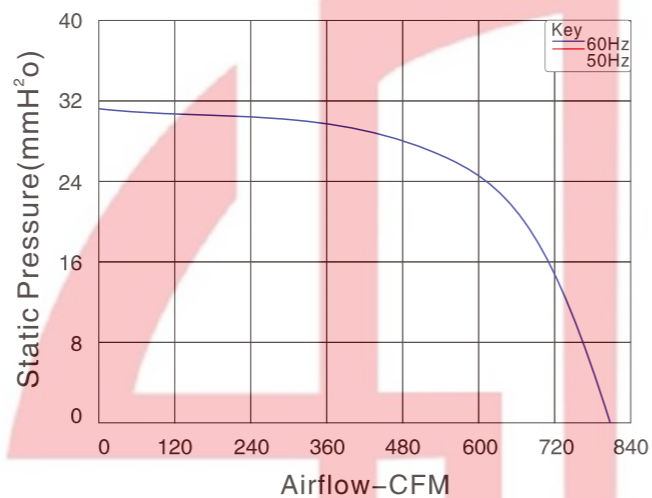

尺寸 Size: Ø200mmX81mm  
风量 Airflow: 795CFM  
噪音 Noise: 53dB(A)  
风叶 Impeller Material: Metal  
工作方式 Operation mode: S1  
温度范围 Operating Temperature: -10°C~+65°C  
防护等级 Type of protection: IP44  
绝缘等级 Insulation class: "B"

产品型号 Model	电压 Voltage VAC	频率 Freq. Hz	电流 Current A	功率 Power W	转速 Speed RPM	风量 Air Flow CFM	静压 Static Pressure mmH <sub>2</sub> O	噪音 Noise dB(A)
YED200CHA2-A01-W	230	50/60	0.82	180	1350	795	30.6	53

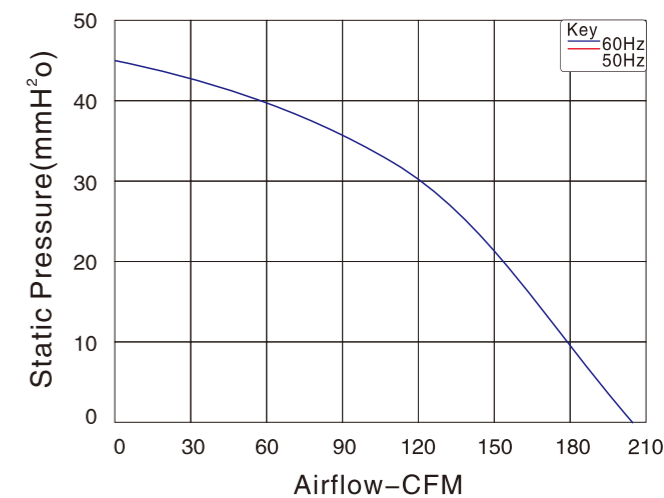
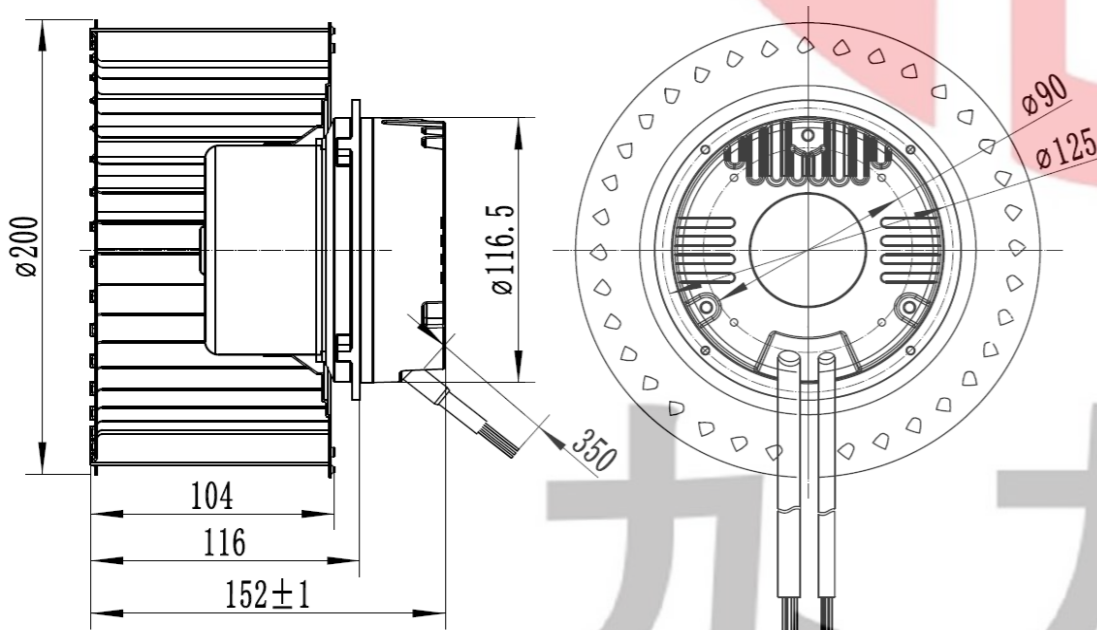

尺寸 Size: Ø133mmX62mm  
风量 Airflow: 202CFM  
噪音 Noise: 63dB(A)  
风叶 Impeller Material: PA66  
工作方式 Operation mode: S1  
温度范围 Operating Temperature: -10°C~+65°C  
防护等级 Type of protection: IP44  
绝缘等级 Insulation class: "B"

产品型号 Model	电压 Voltage VAC	频率 Freq. Hz	电流 Current A	功率 Power W	转速 Speed RPM	风量 Air Flow CFM	静压 Static Pressure mmH <sub>2</sub> O	噪音 Noise dB(A)
YEH133AGA2-A01	230	50/60	0.22	48	4500	202	45	63

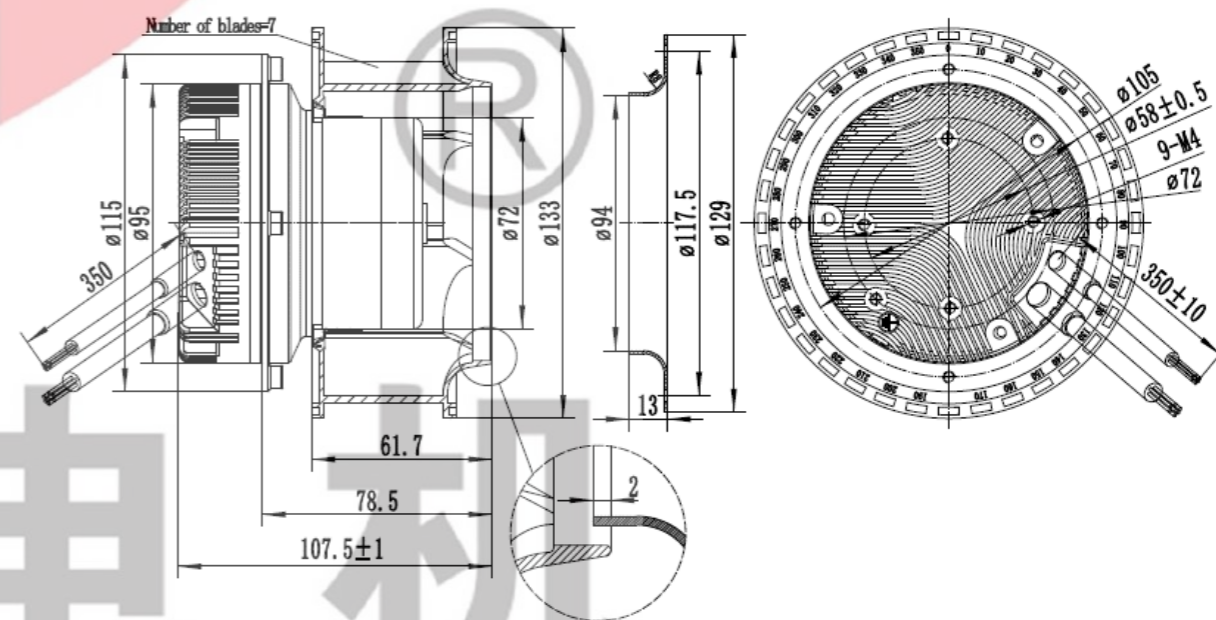

九 龙 电 机

AC Axial Fan  
AC轴流风机

AC All-Metal Axial Fan  
AC全金属轴流风扇

DC Axial Fan  
DC轴流风机

DC Centrifugal Fan  
DC离心风机

EC Axial Fan  
EC轴流风机

EC Centrifugal Fan  
EC离心风机

AC Centrifugal Fan  
AC离心风机

Fan Accessories  
风机配件



JULONG MOTOR  
AC/DC FANS COOLING FANS

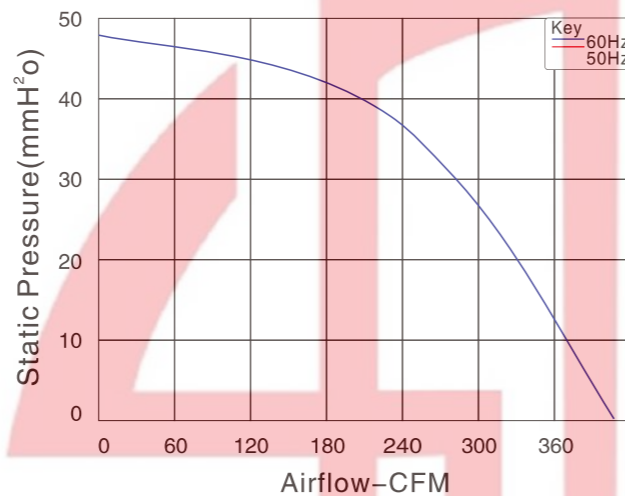

尺寸 Size: Ø175mmX65mm  
 风量 Airflow: 400.5CFM  
 噪音 Noise: 68dB(A)  
 风叶 Impeller Material: PA66  
 工作方式 Operation mode: S1  
 温度范围 Operating Temperature: -10°C~+65°C  
 防护等级 Type of protection: IP44  
 绝缘等级 Insulation class: "B"

产品型号 Model	电压 Voltage VAC	频率 Freq. Hz	电流 Current A	功率 Power W	转速 Speed RPM	风量 Air Flow CFM	静压 Static Pressure mmH <sub>2</sub> O	噪音 Noise dB(A)
YEH175AGA2-A01	230	50/60	0.2	43	3500	400.5	48.3	68

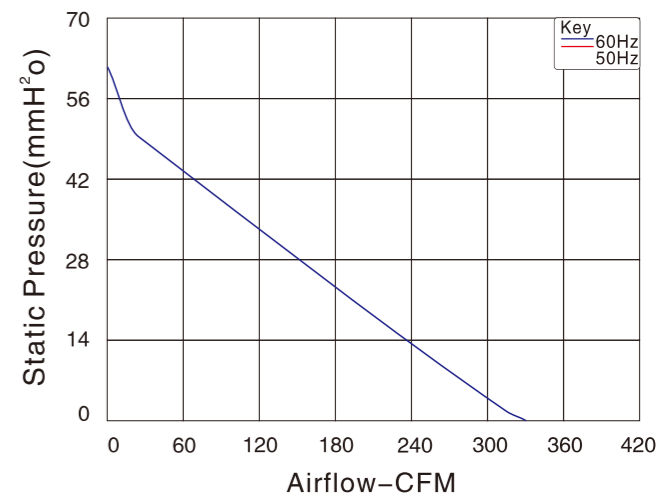
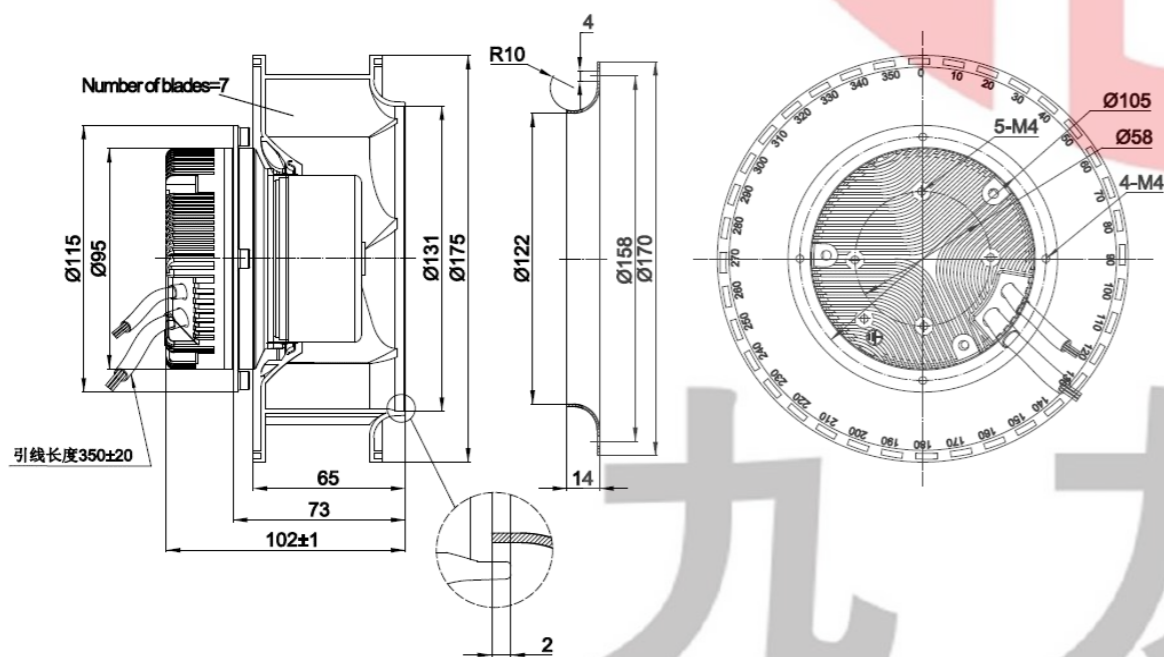

尺寸 Size: Ø180mmX69mm  
 风量 Airflow: 340CFM  
 噪音 Noise: 61dB(A)  
 风叶 Impeller Material: ABS+GF  
 工作方式 Operation mode: S1  
 温度范围 Operating Temperature: -10°C~+65°C  
 防护等级 Type of protection: IP44  
 绝缘等级 Insulation class: "B"

产品型号 Model	电压 Voltage VAC	频率 Freq. Hz	电流 Current A	功率 Power W	转速 Speed RPM	风量 Air Flow CFM	静压 Static Pressure mmH <sub>2</sub> O	噪音 Noise dB(A)
YEH180AGA2-A01	230	50/60	0.45	58	2800	340	62.7	61

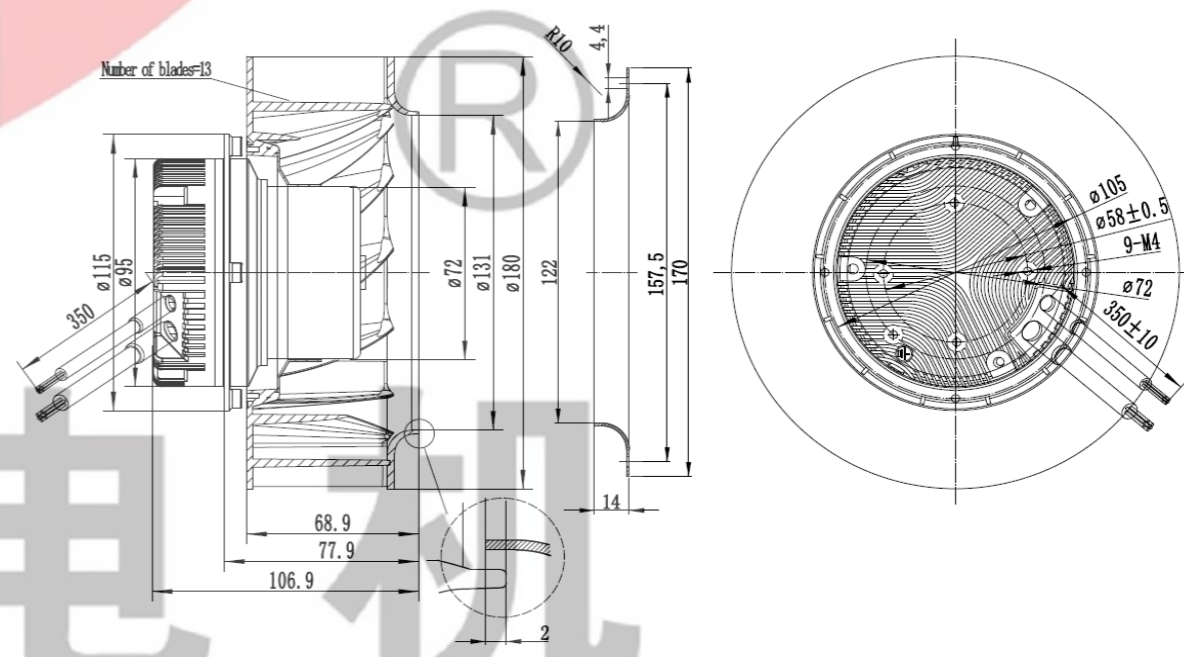

Http://www.xtgygs.cn



JULONG MOTOR  
AC/DC FANS COOLING FANS



UL  
E248719



本样图仅供参考，具体以实物为准。  
This sample book is for reference only. Please refer to the specification for details.  
如需特殊电压也可根据需求提供。本公司保留技术知识产权。  
Special voltage may be provided flexibly according to the requirement. All technical modification rights reserved.

Http://www.xtgygs.cn

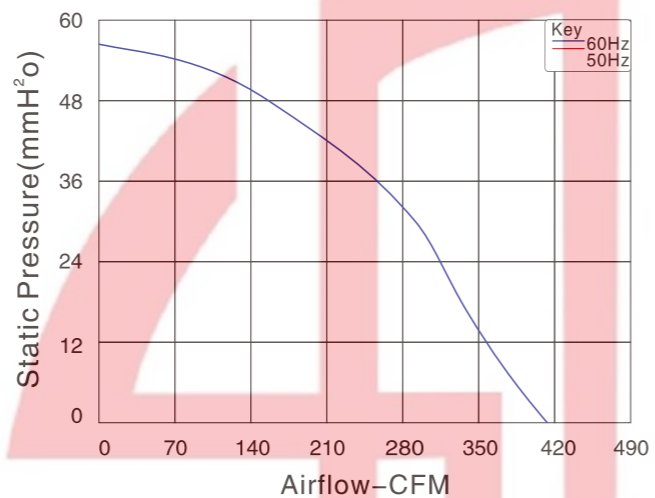

尺寸 Size: Ø190mmX61mm  
风量 Airflow: 414.8CFM  
噪音 Noise: 66.7dB(A)  
风叶 Impeller Material: PA66  
工作方式 Operation mode: S1  
温度范围 Operating Temperature: -10°C~+65°C  
防护等级 Type of protection: IP44  
绝缘等级 Insulation class: "B"

产品型号 Model	电压 Voltage VAC	频率 Freq. Hz	电流 Current A	功率 Power W	转速 Speed RPM	风量 Air Flow CFM	静压 Static Pressure mmH <sub>2</sub> O	噪音 Noise dB(A)
YEH190BGA2-A01	230	50/60	0.63	85	3400	414.8	56.5	66.7

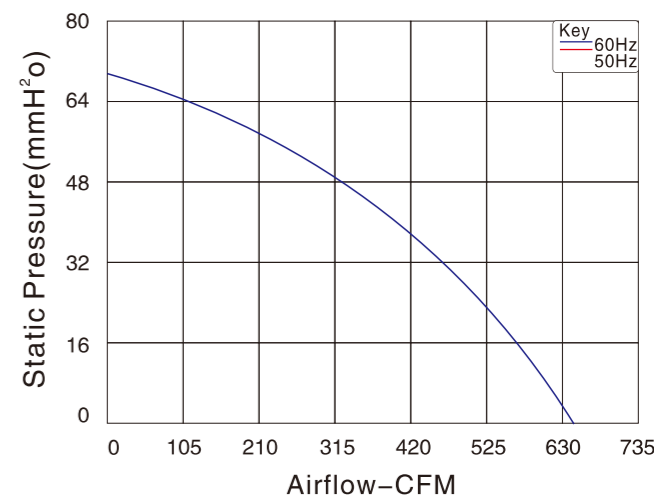

尺寸 Size: Ø220mmX65mm  
风量 Airflow: 645.5CFM  
噪音 Noise: 77.2dB(A)  
风叶 Impeller Material: PA66  
工作方式 Operation mode: S1  
温度范围 Operating Temperature: -10°C~+65°C  
防护等级 Type of protection: IP44  
绝缘等级 Insulation class: "B"

产品型号 Model	电压 Voltage VAC	频率 Freq. Hz	电流 Current A	功率 Power W	转速 Speed RPM	风量 Air Flow CFM	静压 Static Pressure mmH <sub>2</sub> O	噪音 Noise dB(A)
YEH220AGA2-A01	230	50/60	0.55	170	3100	645.5	70	77.2

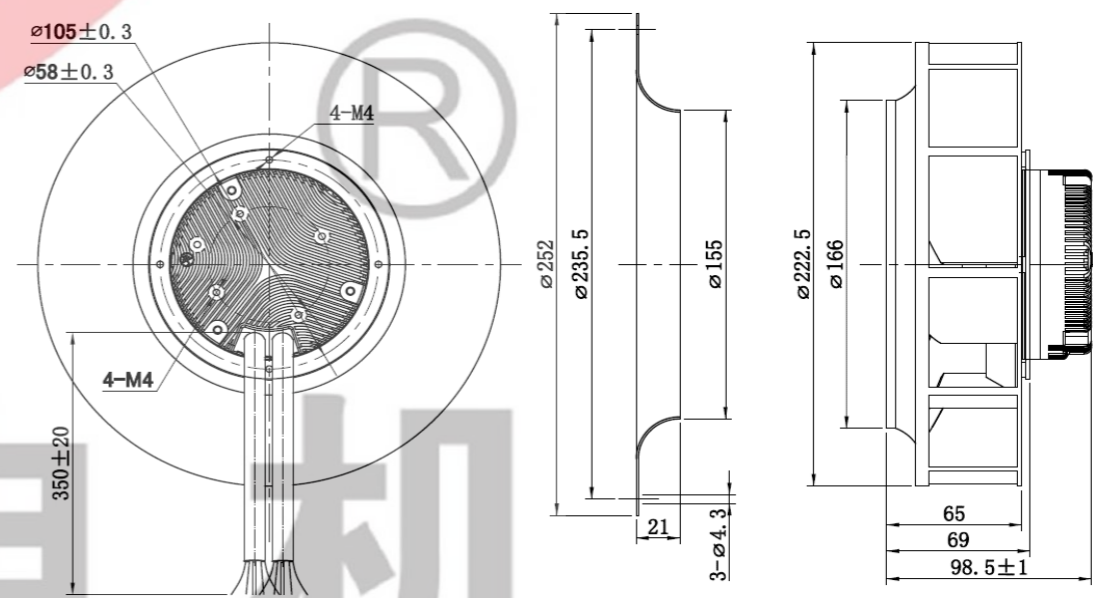
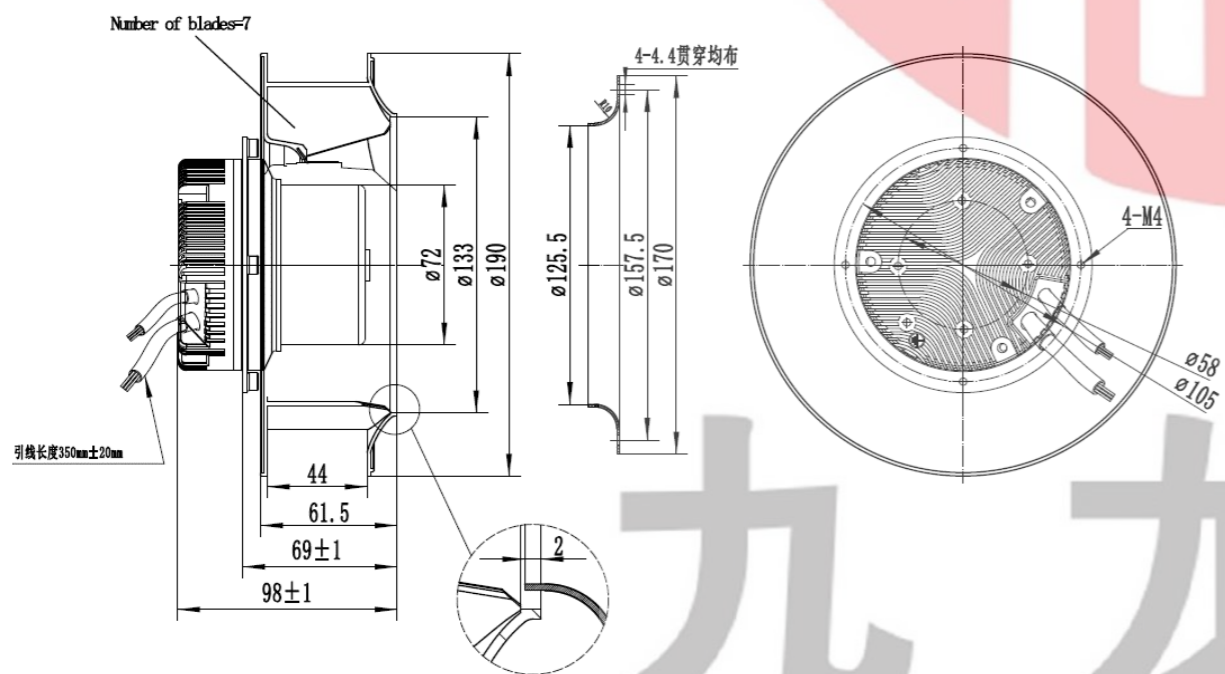

九 龙 电 机

AC Axial Fan  
AC轴流风机

AC All-Metal Axial Fan  
AC全金属轴流风扇

DC Axial Fan  
DC轴流风机

DC Centrifugal Fan  
DC离心风机

EC Axial Fan  
EC轴流风机

EC Centrifugal Fan  
EC离心风机

AC Centrifugal Fan  
AC离心风机

Fan Accessories  
风机配件



本样图仅供参考，具体以实物为准。  
This sample book is for reference only. Please refer to the specification for details.  
如需特殊电压也可根据需求提供。本公司保留技术更改权利。  
Special voltage may be provided flexibly according to the enquiry. All technical modification rights reserved.

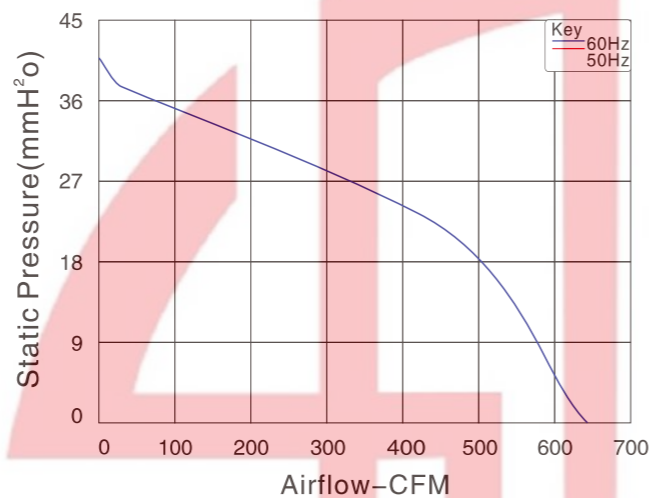

尺寸 Size: Ø220mmX93mm  
 风量 Airflow: 597.4CFM  
 噪音 Noise: 65.4dB(A)  
 风叶 Impeller Material: ABS+GF  
 工作方式 Operation mode: S1  
 温度范围 Operating Temperature: -10°C~+65°C  
 防护等级 Type of protection: IP44  
 绝缘等级 Insulation class: "B"

产品型号 Model	电压 Voltage VAC	频率 Freq. Hz	电流 Current A	功率 Power W	转速 Speed RPM	风量 Air Flow CFM	静压 Static Pressure mmH <sub>2</sub> O	噪音 Noise dB(A)
YE220BGA2-A01	230	50/60	0.58	100	2200	597.4	40.2	65.4

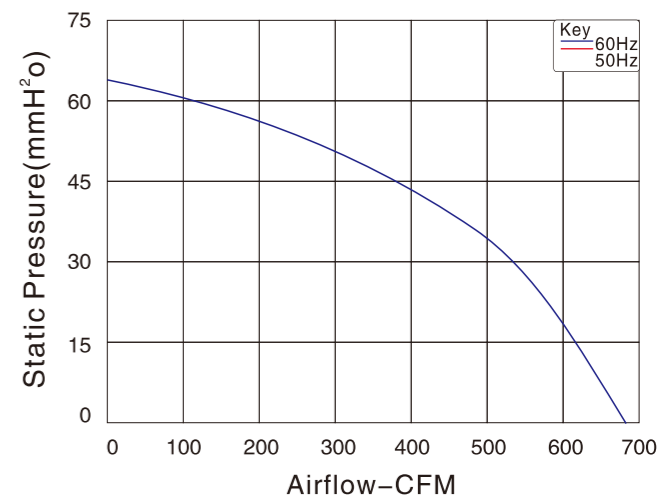

尺寸 Size: Ø225mmX75mm  
 风量 Airflow: 683CFM  
 噪音 Noise: 73dB(A)  
 风叶 Impeller Material: PA66  
 工作方式 Operation mode: S1  
 温度范围 Operating Temperature: -10°C~+65°C  
 防护等级 Type of protection: IP44  
 绝缘等级 Insulation class: "B"

产品型号 Model	电压 Voltage VAC	频率 Freq. Hz	电流 Current A	功率 Power W	转速 Speed RPM	风量 Air Flow CFM	静压 Static Pressure mmH <sub>2</sub> O	噪音 Noise dB(A)
YE225BGA2-A01	230	50/60	0.28	85	3000	683	66.3	73

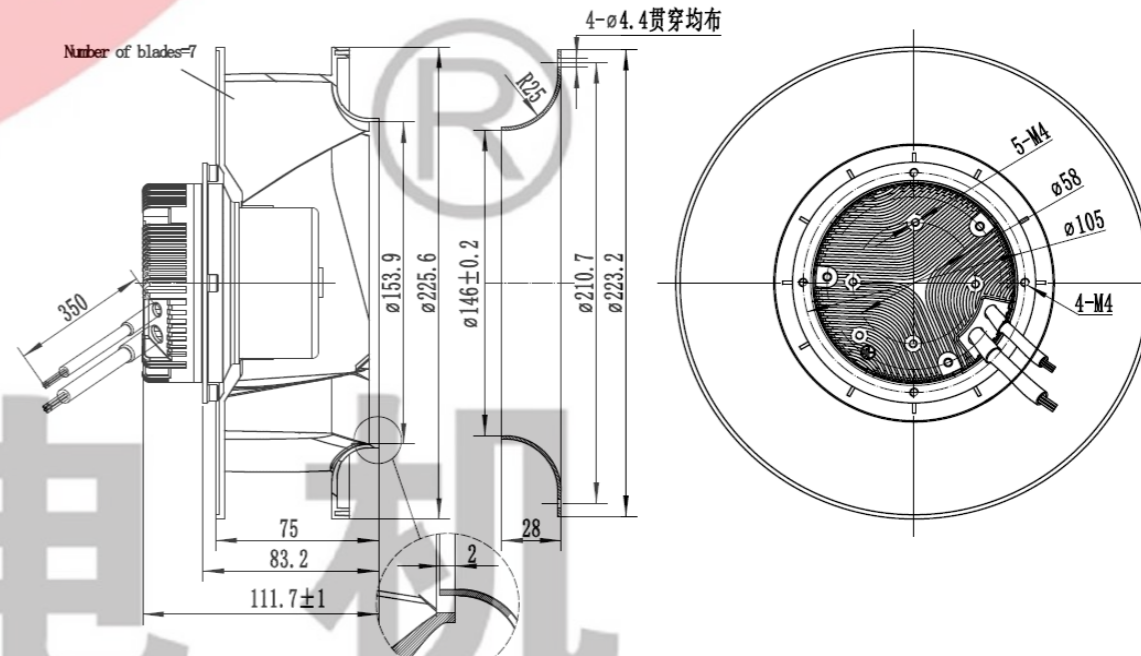
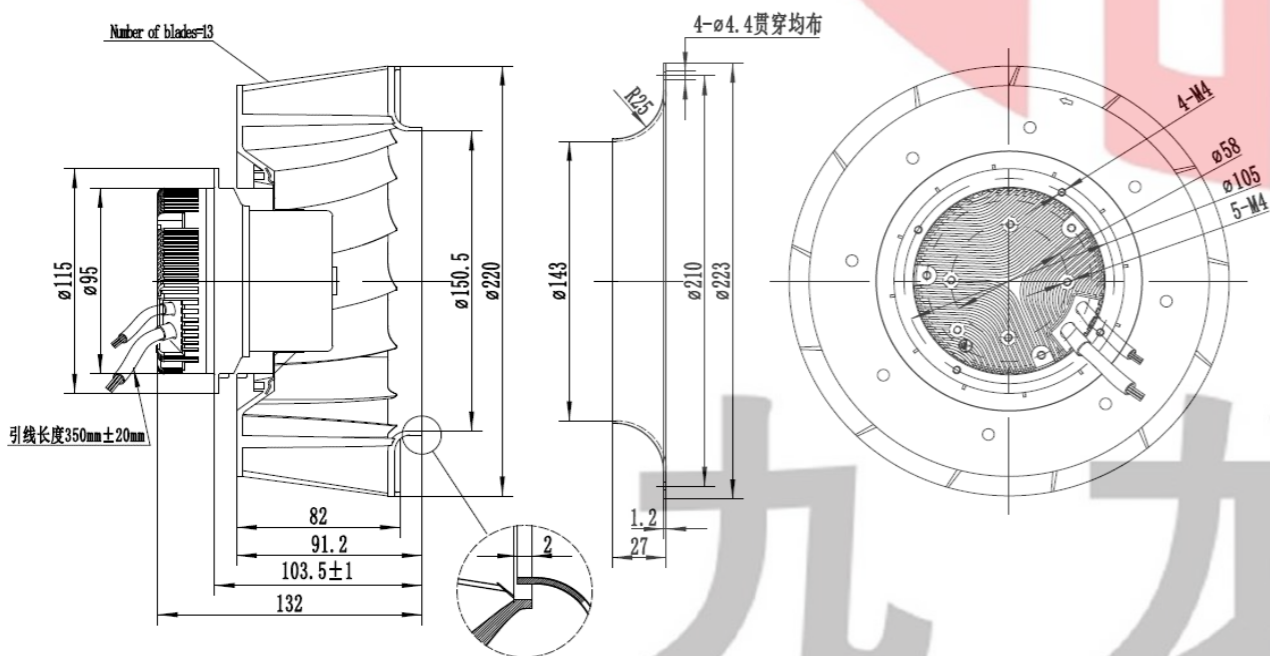



JIULONG MOTOR  
AC/DC FANS COOLING FANS



UL  
E248719



本样图仅供参考，具体以实物为准。  
This sample book is for reference only. Please refer to the specification for details.  
如需特殊电压也可单独定制提供。本公司保留技术知识产权。  
Special voltage may be provided flexibly according to the enquiry. All technical modification rights reserved.

Http://www.xtgygs.cn

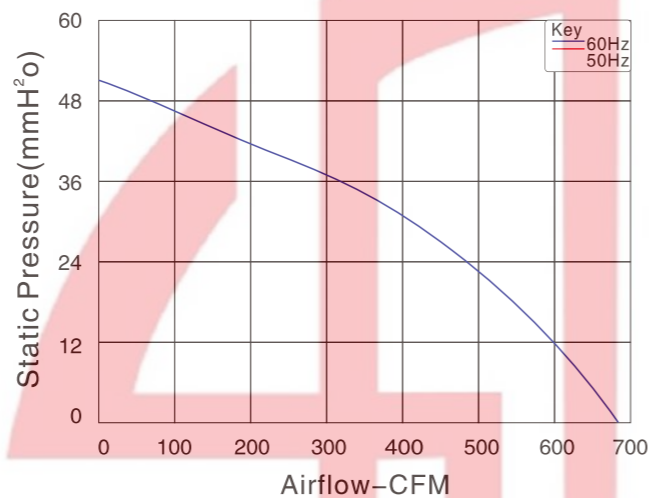

尺寸 Size:  $\varnothing 225\text{mm} \times 89\text{mm}$   
风量 Airflow: 678.8CFM  
噪音 Noise: 68.1dB(A)  
风叶 Impeller Material: PA66  
工作方式 Operation mode: S1  
温度范围 Operating Temperature:  $-10^{\circ}\text{C} \sim +65^{\circ}\text{C}$   
防护等级 Type of protection: IP44  
绝缘等级 Insulation class: "B"

产品型号 Model	电压 Voltage VAC	频率 Freq. Hz	电流 Current A	功率 Power W	转速 Speed RPM	风量 Air Flow CFM	静压 Static Pressure mmH <sub>2</sub> O	噪音 Noise dB(A)
YE H225CGA2-A01	230	50/60	0.55	120	2500	678.8	51.9	68.1

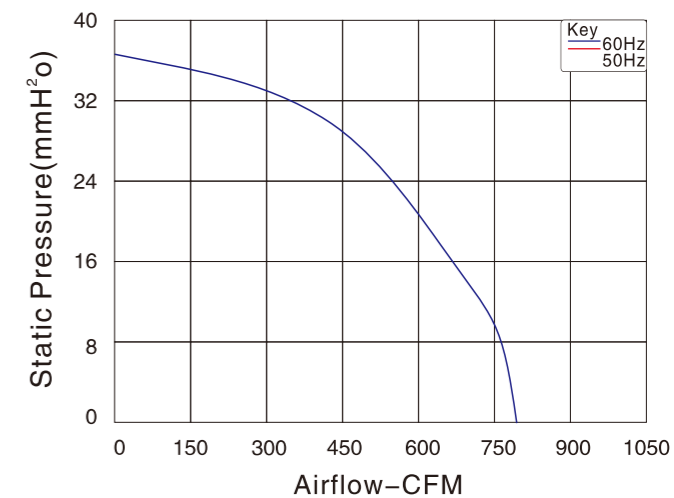

尺寸 Size:  $\varnothing 225\text{mm} \times 89\text{mm}$   
风量 Airflow: 814.6CFM  
噪音 Noise: 72.1dB(A)  
风叶 Impeller Material: PA66  
工作方式 Operation mode: S1  
温度范围 Operating Temperature:  $-10^{\circ}\text{C} \sim +65^{\circ}\text{C}$   
防护等级 Type of protection: IP44  
绝缘等级 Insulation class: "B"

产品型号 Model	电压 Voltage VAC	频率 Freq. Hz	电流 Current A	功率 Power W	转速 Speed RPM	风量 Air Flow CFM	静压 Static Pressure mmH <sub>2</sub> O	噪音 Noise dB(A)
YE H225CHA2-A01	230	50/60	0.85	140	3000	814.6	74.7	72.1

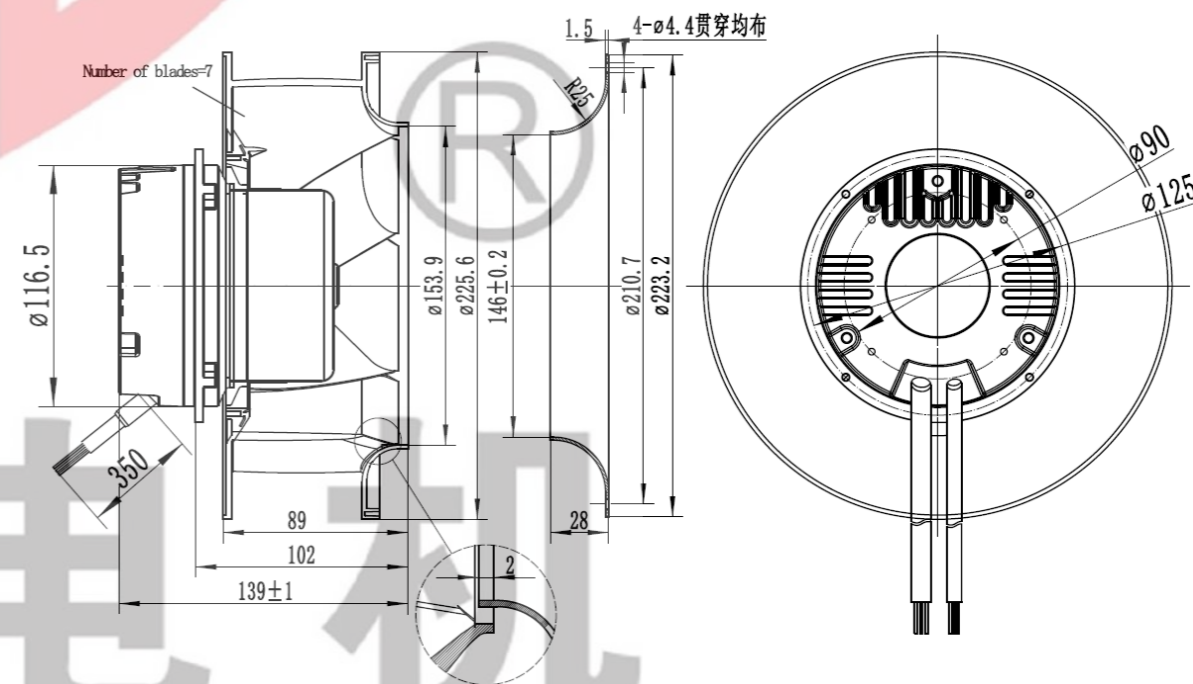
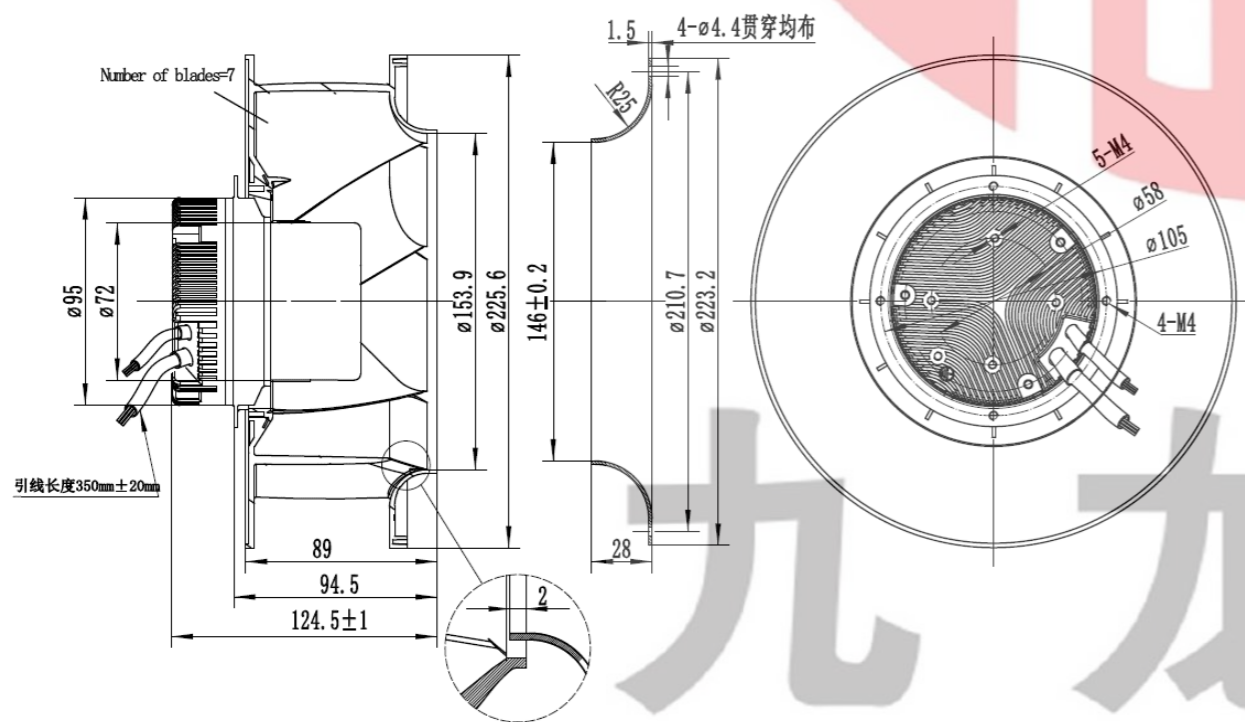

AC Axial Fan  
AC轴流风机

AC All-Metal Axial Fan  
AC全金属轴流风扇

DC Axial Fan  
DC轴流风机

DC Centrifugal Fan  
DC离心风机

EC Axial Fan  
EC轴流风机

EC Centrifugal Fan  
EC离心风机

AC Centrifugal Fan  
AC离心风机

Fan Accessories  
风机配件

270

269



JIULONG MOTOR  
AC/DC FANS COOLING FANS



UL  
E248719



本样机仅供参考，具体以实物为准。  
This sample book is for reference only. Please refer to the specification for details.  
如需特殊电压也可特别定制提供。本公司保留技术知识产权。  
Special voltage may be provided flexibly according to the enquiry. All technical modification rights reserved.

Http://www.xtgygs.cn

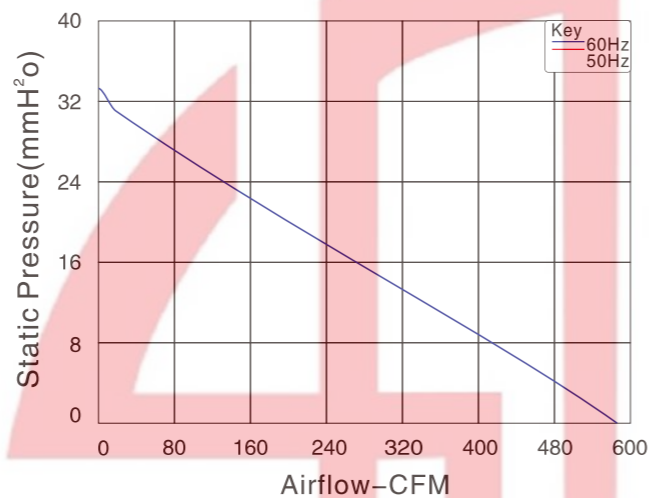

尺寸 Size: 225mmX93mm  
风量 Airflow: 543.1CFM  
噪音 Noise: 63dB(A)  
风叶 Impeller Material: ABS+GF  
工作方式 Operation mode: S1  
温度范围 Operating Temperature: -10°C~+65°C  
防护等级 Type of protection: IP44  
绝缘等级 Insulation class: "B"

产品型号 Model	电压 Voltage VAC	频率 Freq. Hz	电流 Current A	功率 Power W	转速 Speed RPM	风量 Air Flow CFM	静压 Static Pressure mmH <sub>2</sub> O	噪音 Noise dB(A)
YE225DGA2-01	230	50/60	0.26	80	2000	543.1	33.2	63

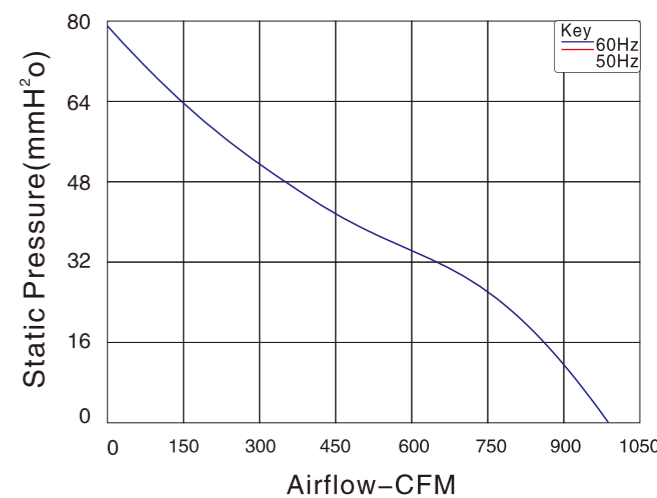

尺寸 Size: Ø250mmX81mm  
风量 Airflow: 985.4CFM  
噪音 Noise: 78.1dB(A)  
风叶 Impeller Material: Metal  
工作方式 Operation mode: S1  
温度范围 Operating Temperature: -10°C~+65°C  
防护等级 Type of protection: IP44  
绝缘等级 Insulation class: "B"

产品型号 Model	电压 Voltage VAC	频率 Freq. Hz	电流 Current A	功率 Power W	转速 Speed RPM	风量 Air Flow CFM	静压 Static Pressure mmH <sub>2</sub> O	噪音 Noise dB(A)
YE250AHA2-01	230	50/60	0.9	180	3000	985.4	78.7	78.1

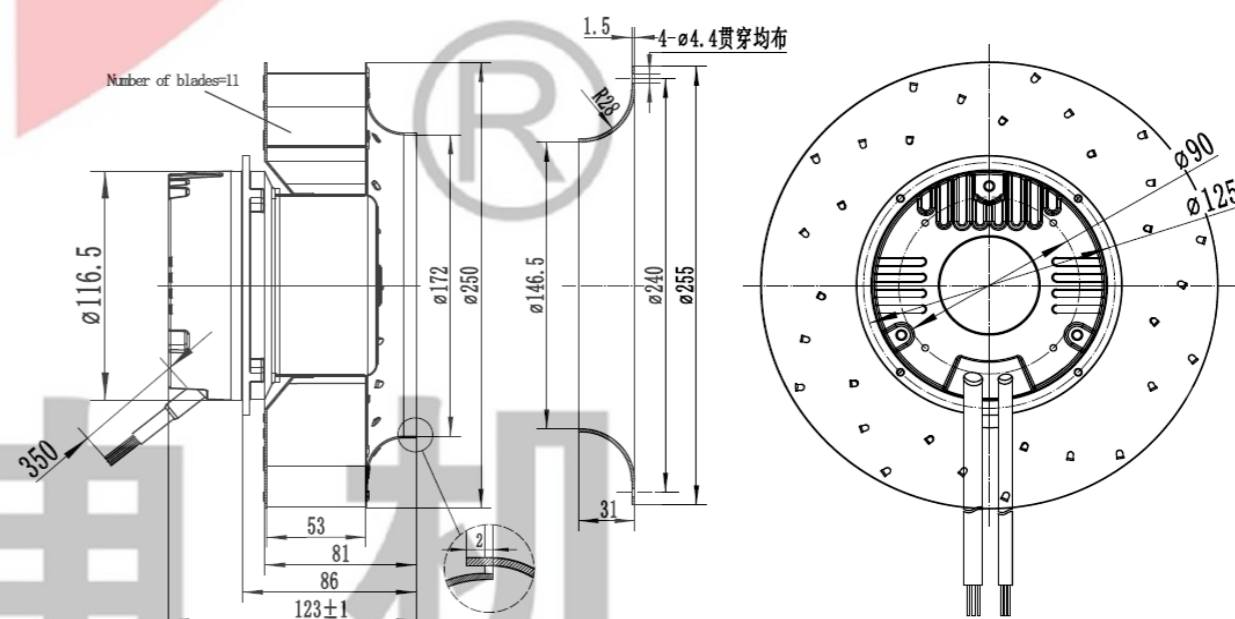
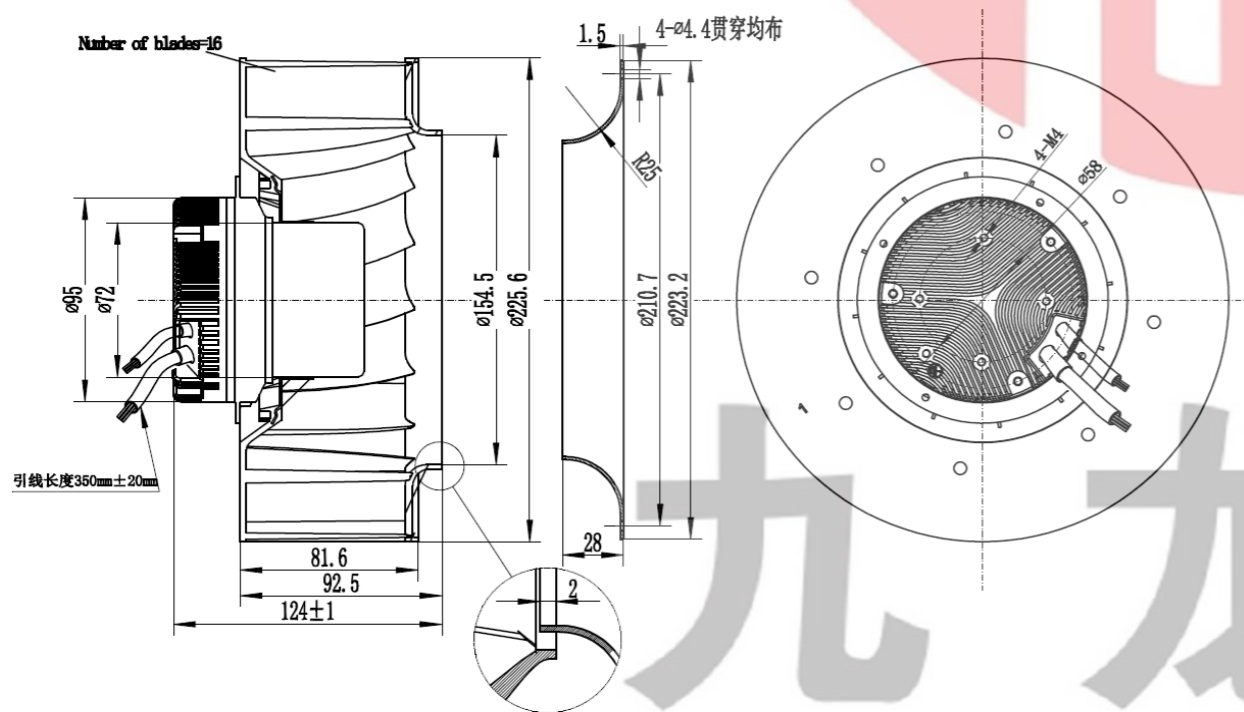

AC Axial Fan  
AC轴流风机

AC All-Metal Axial Fan  
AC全金属轴流风扇

DC Axial Fan  
DC轴流风机

DC Centrifugal Fan  
DC离心风机

EC Axial Fan  
EC轴流风机

EC Centrifugal Fan  
EC离心风机

AC Centrifugal Fan  
AC离心风机

Fan Accessories  
风机配件



JULONG MOTOR  
AC/DC FANS COOLING FANS



本样图仅供参考，具体以实物为准。  
This sample book is for reference only. Please refer to the specification for details.  
如需特殊电压也可单独定制提供。本公司保留技术知识产权。  
Special voltage may be provided flexibly according to the enquiry. All technical modification rights reserved.

Http://www.xtgygs.cn

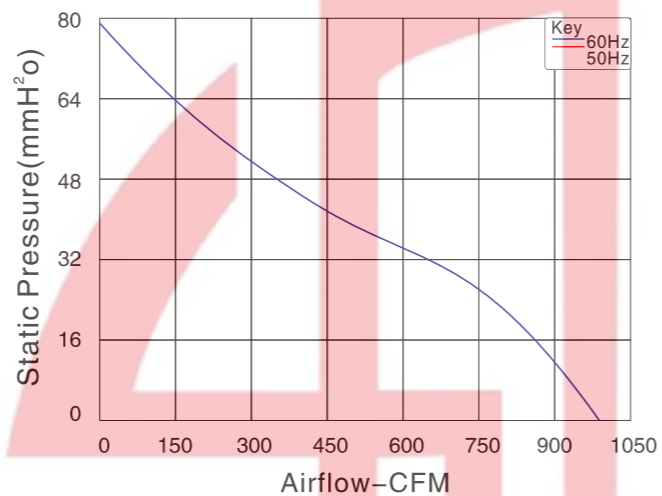

尺寸 Size: 250mmX86mm  
风量 Airflow: 985.4CFM  
噪音 Noise: 78.1dB(A)  
风叶 Impeller Material: PA66  
工作方式 Operation mode: S1  
温度范围 Operating Temperature: -10°C~+65°C  
防护等级 Type of protection: IP44  
绝缘等级 Insulation class: "B"

产品型号 Model	电压 Voltage VAC	频率 Freq. Hz	电流 Current A	功率 Power W	转速 Speed RPM	风量 Air Flow CFM	静压 Static Pressure mmH <sub>2</sub> O	噪音 Noise dB(A)
YEH250BHA2-A01	230	50/60	0.9	170	3000	985.4	78.7	78.1

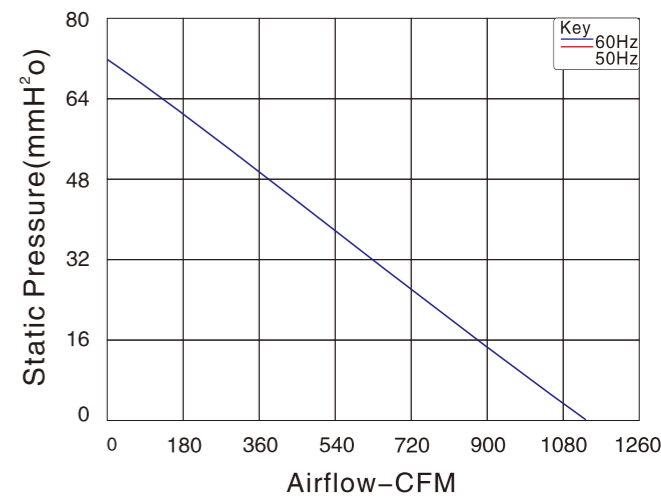
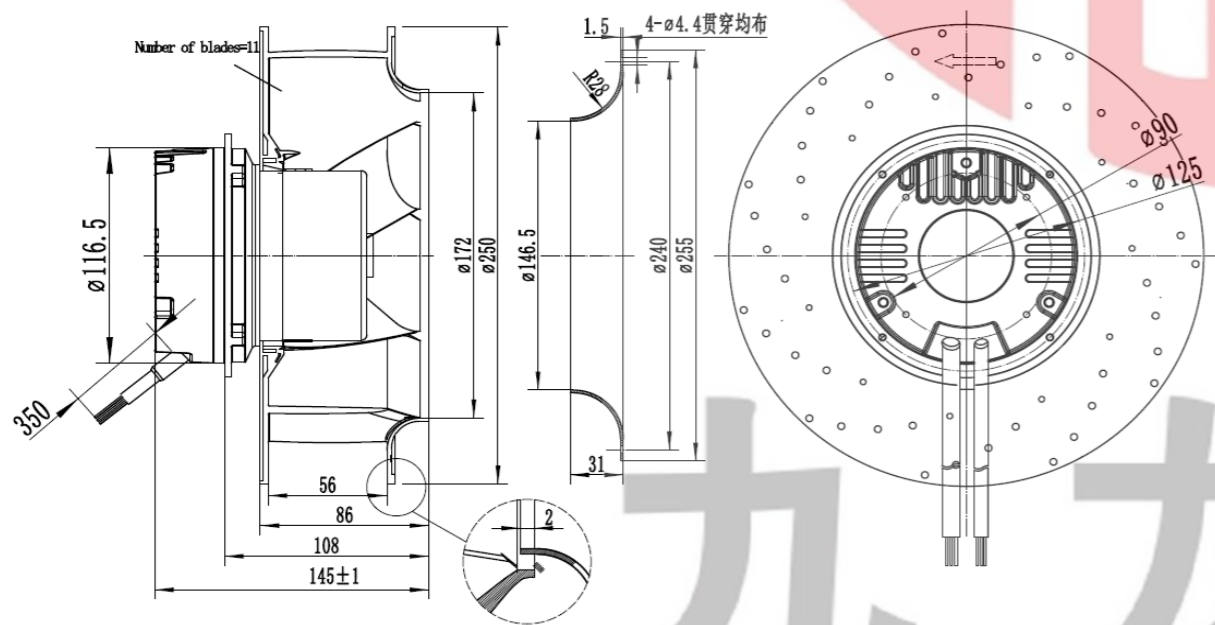

尺寸 Size: Ø280mmX81mm  
风量 Airflow: 1126CFM  
噪音 Noise: 74.6dB(A)  
风叶 Impeller Material: Metal  
工作方式 Operation mode: S1  
温度范围 Operating Temperature: -10°C~+65°C  
防护等级 Type of protection: IP44  
绝缘等级 Insulation class: "B"

产品型号 Model	电压 Voltage VAC	频率 Freq. Hz	电流 Current A	功率 Power W	转速 Speed RPM	风量 Air Flow CFM	静压 Static Pressure mmH <sub>2</sub> O	噪音 Noise dB(A)
YEH280AHA2-A01	230	50/60	0.85	150	2500	1126	71.5	74.6

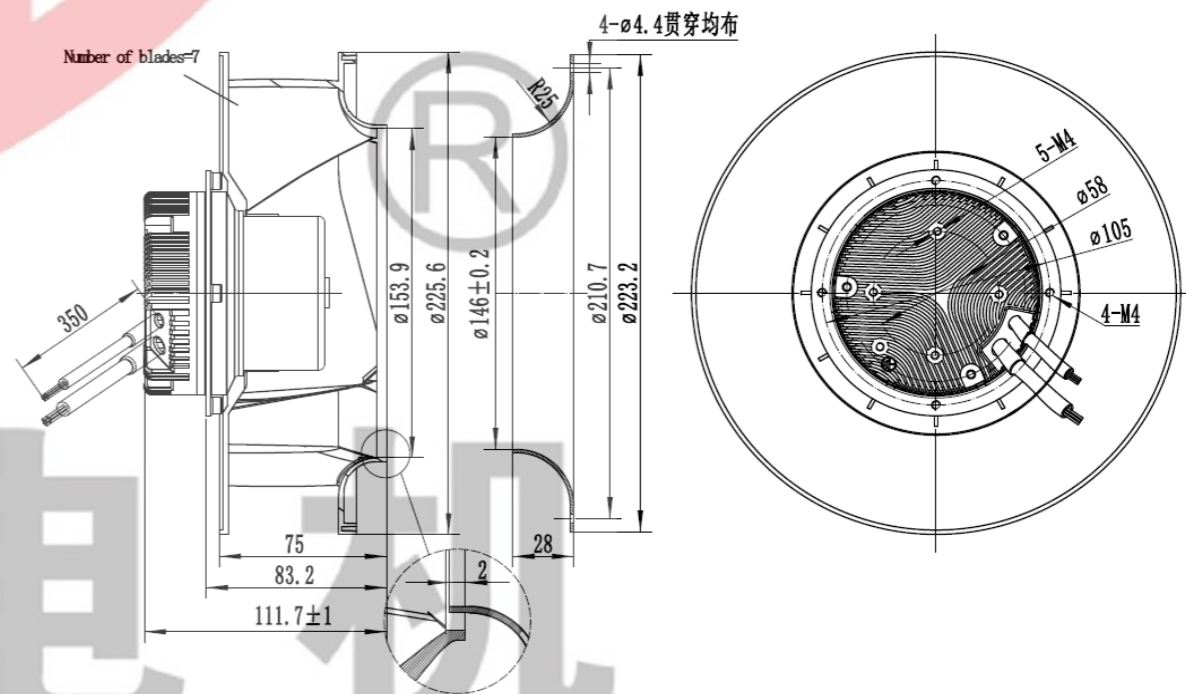

九 龙 电 机

AC Axial Fan  
AC轴流风机

AC All-Metal Axial Fan  
AC全金属轴流风扇

DC Axial Fan  
DC轴流风机

DC Centrifugal Fan  
DC离心风机

EC Axial Fan  
EC轴流风机

EC Centrifugal Fan  
EC离心风机

AC Centrifugal Fan  
AC离心风机

Fan Accessories  
风机配件



JIULONG MOTOR  
AC/DC FANS COOLING FANS



UL  
E248719



本样图仅供参考，具体以实物为准。  
This sample book is for reference only. Please refer to the specification for details.  
如需特殊电压也可根据需求提供。本公司保留技术知识产权。  
Special voltage may be provided according to the enquiry. All technical modification rights reserved.

Http://www.xtgygs.cn

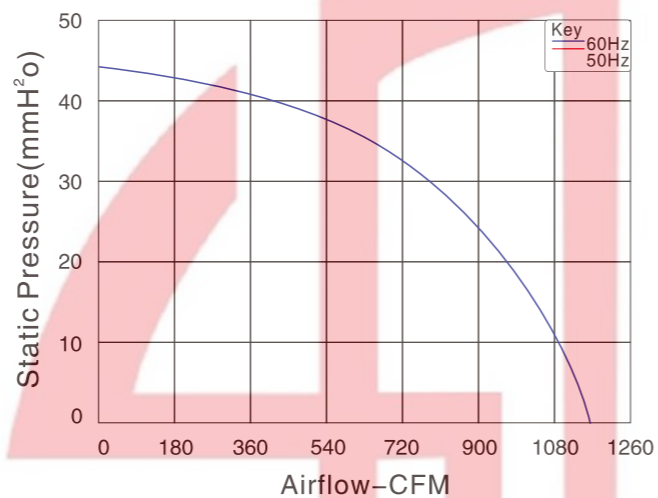

尺寸 Size: 280mmX112mm  
风量 Airflow: 1167CFM  
噪音 Noise: 45dB(A)  
风叶 Impeller Material: Metal  
工作方式 Operation mode: S1  
温度范围 Operating Temperature: -10°C~+65°C  
防护等级 Type of protection: IP44  
绝缘等级 Insulation class: "B"

产品型号 Model	电压 Voltage VAC	频率 Freq. Hz	电流 Current A	功率 Power W	转速 Speed RPM	风量 Air Flow CFM	静压 Static Pressure mmH <sub>2</sub> O	噪音 Noise dB(A)
YE H280BHA2-01	230	50/60	0.8	130	2000	1167	45	70.2

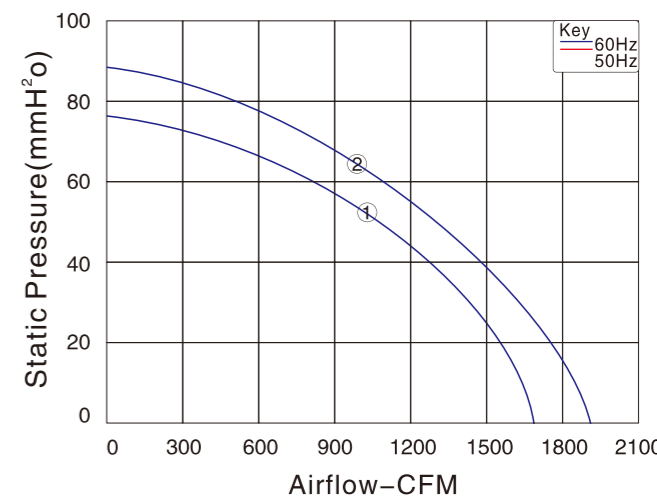
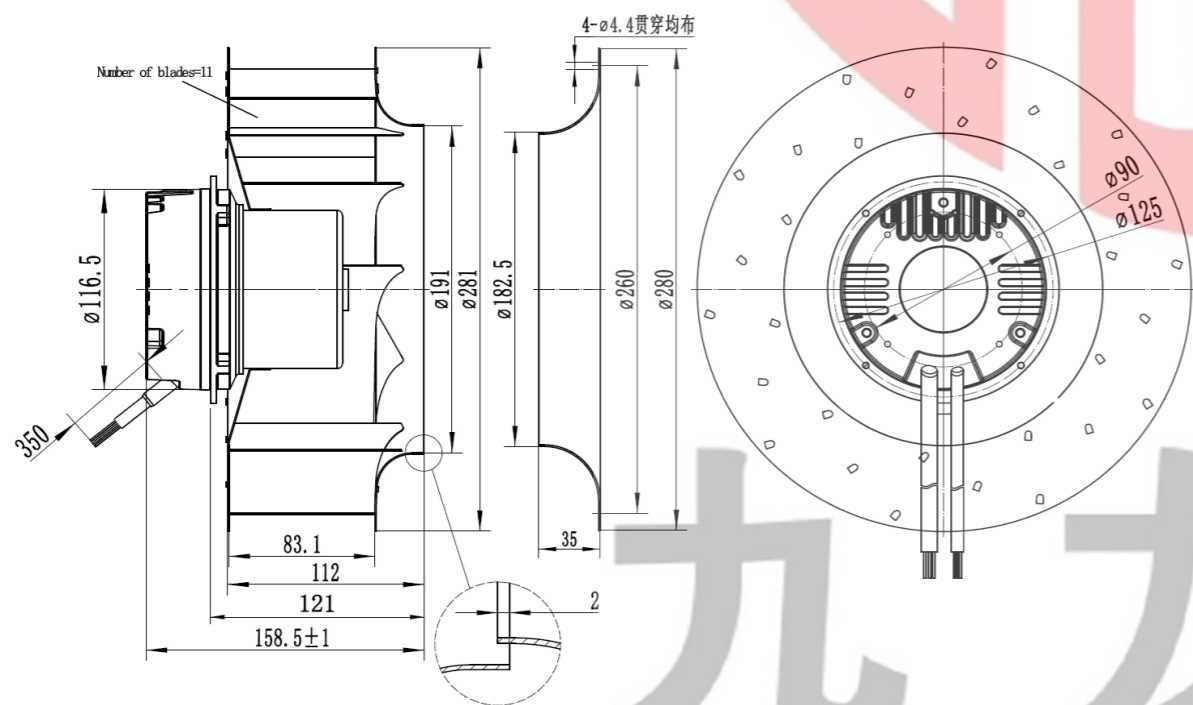

尺寸 Size: 320mmX108mm/140mm  
风量 Airflow: 1579CFM/1928CFM  
噪音 Noise: 72.9dB(A)/75.9dB(A)  
风叶 Impeller Material: Aluminium  
工作方式 Operation mode: S1  
温度范围 Operating Temperature: -10°C~+65°C  
防护等级 Type of protection: IP44  
绝缘等级 Insulation class: "B"

产品型号 Model	电压 Voltage VAC	频率 Freq. Hz	电流 Current A	功率 Power W	转速 Speed RPM	风量 Air Flow CFM	静压 Static Pressure mmH <sub>2</sub> O	噪音 Noise dB(A)
YE H320AIA2-A01 ①	230	50/60	1.4	300	2200	1579	77	72.9
YE H320BIA2-A01 ②	230	50/60	1.45	320	2200	1928	89.4	75.9

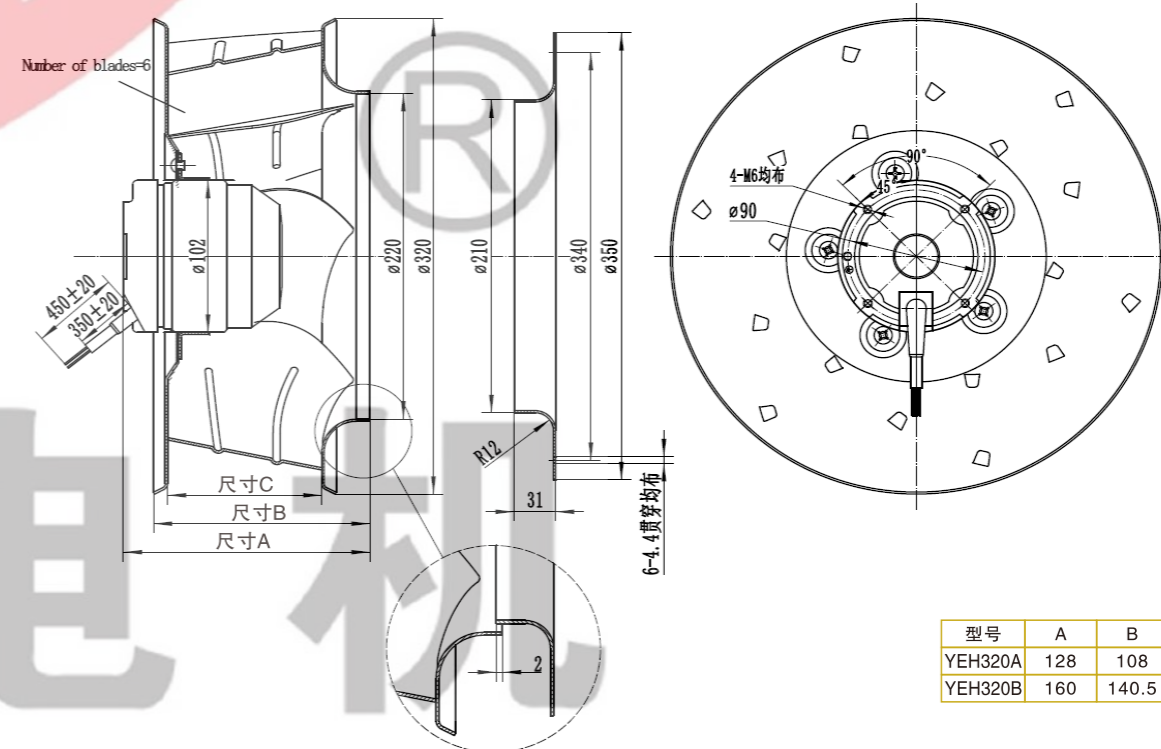

型号	A	B	C
YE H320A	128	108	70
YE H320B	160	140.5	100

九 龙 电 机



JIULONG MOTOR  
AC/DC FANS COOLING FANS



UL  
E248719



本样图仅供参考，具体以实物为准。  
This sample book is for reference only. Please refer to the specification for details.  
如需特殊电压也可相照应提供，本公司保留技术知识产权。  
Special voltage may be provided flexibly according to the enquiry, although technical modification is reserved.

Http://www.xtgygs.cn

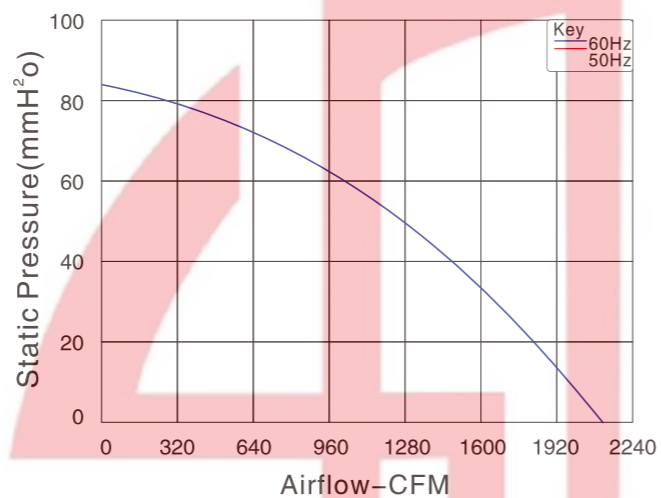

尺寸 Size: Ø335mmX147mm  
风量 Airflow: 2122CFM  
噪音 Noise: 73.4dB(A)  
风叶 Impeller Material: Aluminium  
工作方式 Operation mode: S1  
温度范围 Operating Temperature: -10°C~+65°C  
防护等级 Type of protection: IP44  
绝缘等级 Insulation class: "B"

产品型号 Model	电压 Voltage VAC	频率 Freq. Hz	电流 Current A	功率 Power W	转速 Speed RPM	风量 Air Flow CFM	静压 Static Pressure mmH <sub>2</sub> O	噪音 Noise dB(A)
YE335AIA2-A01	230	50/60	1.5	330	1900	2122	84.3	73.4

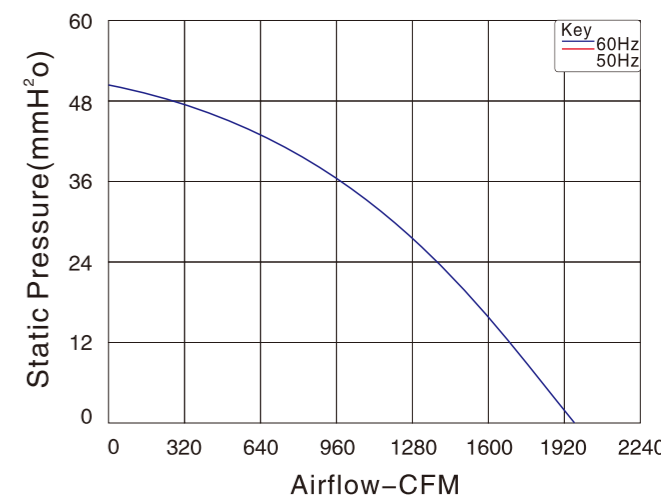
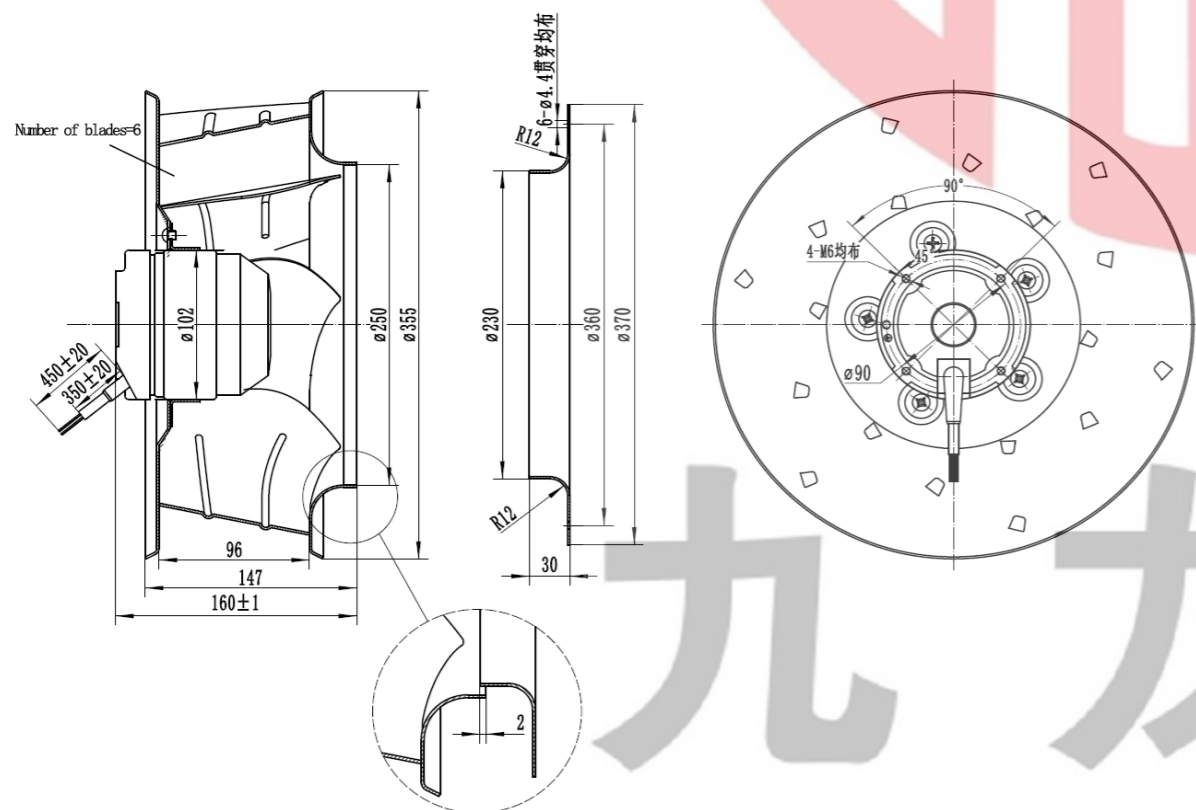

尺寸 Size: 400mmX140mm  
风量 Airflow: 1943CFM  
噪音 Noise: 68dB(A)  
风叶 Impeller Material: Aluminium  
工作方式 Operation mode: S1  
温度范围 Operating Temperature: -10°C~+65°C  
防护等级 Type of protection: IP44  
绝缘等级 Insulation class: "B"

产品型号 Model	电压 Voltage VAC	频率 Freq. Hz	电流 Current A	功率 Power W	转速 Speed RPM	风量 Air Flow CFM	静压 Static Pressure mmH <sub>2</sub> O	噪音 Noise dB(A)
YE400AIA2-A01	230	50/60	1.1	245	1450	1943	51	68

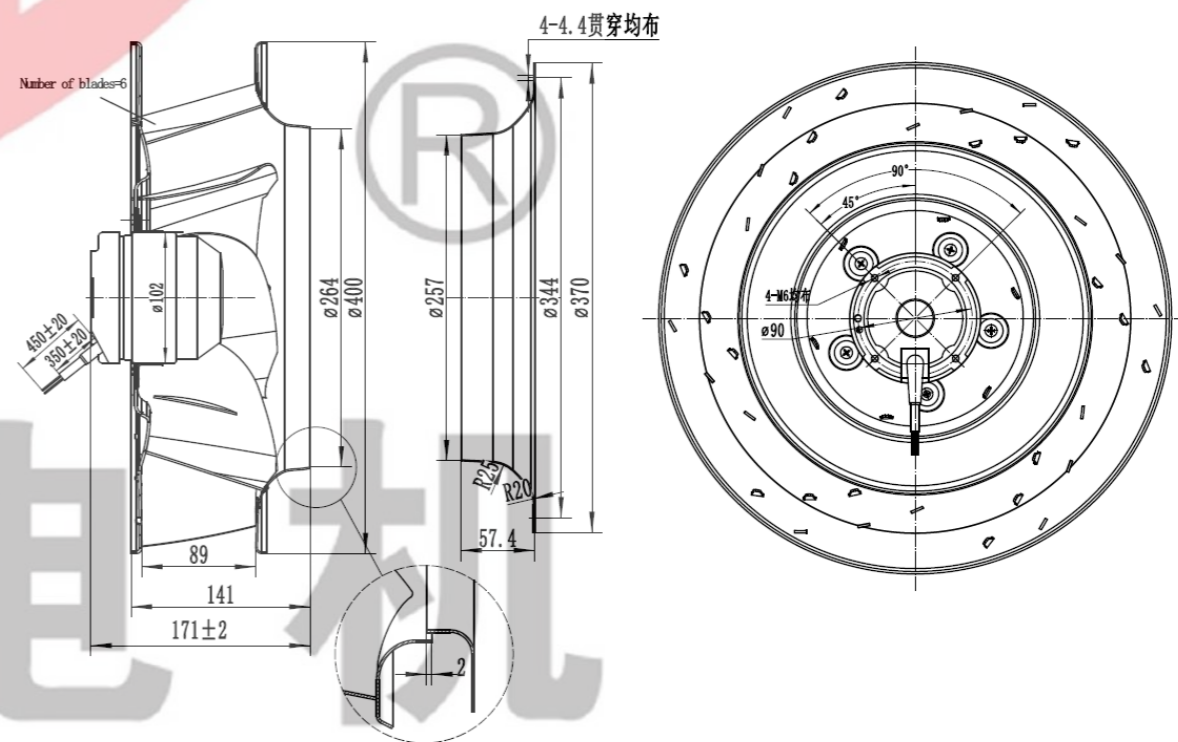

AC Axial Fan  
AC轴流风机

AC All-Metal Axial Fan  
AC全金属轴流风扇

DC Axial Fan  
DC轴流风机

DC Centrifugal Fan  
DC离心风机

EC Axial Fan  
EC轴流风机

EC Centrifugal Fan  
EC离心风机

AC Centrifugal Fan  
AC离心风机

Fan Accessories  
风机配件



尺寸 Size: 400mmX188mm  
风量 Airflow: 2355CFM  
噪音 Noise: 68dB(A)  
风叶 Impeller Material: Aluminium  
工作方式 Operation mode: S1  
温度范围 Operating Temperature: -10°C~+65°C  
防护等级 Type of protection: IP44  
绝缘等级 Insulation class: "B"

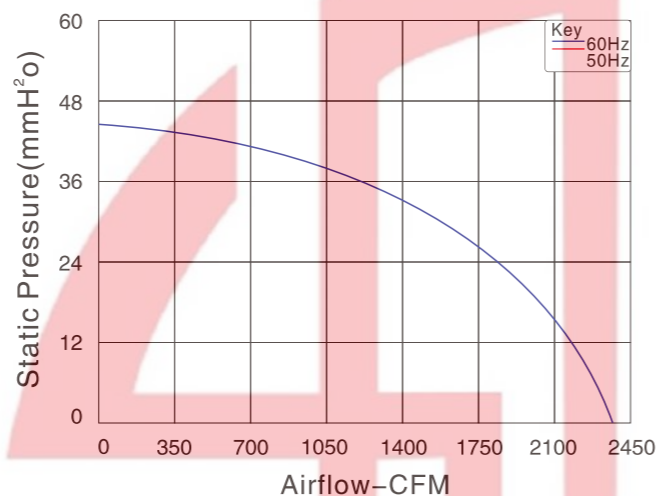

产品型号 Model	电压 Voltage VAC	频率 Freq. Hz	电流 Current A	功率 Power W	转速 Speed RPM	风量 Air Flow CFM	静压 Static Pressure mmH <sub>2</sub> O	噪音 Noise dB(A)
YE400BIA2-A01	230	50/60	1.5	320	1350	2355	44.8	68

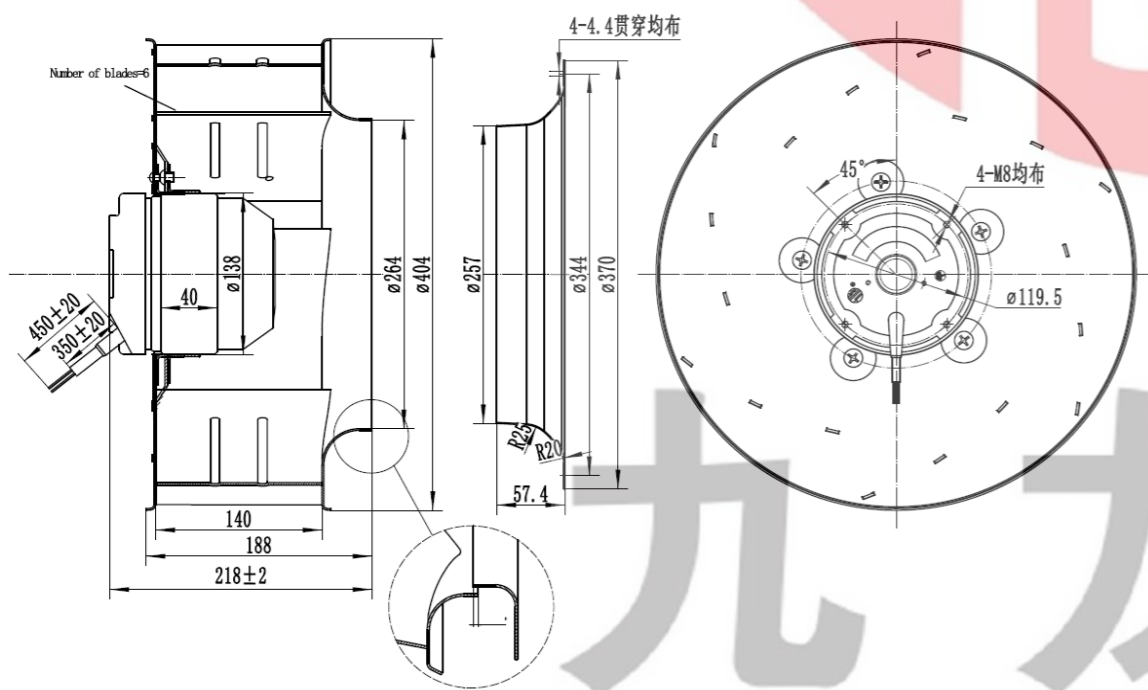

尺寸 Size: Ø133mmX190mm  
风量 Airflow: 427.8CFM  
噪音 Noise: 56.7dB(A)  
风叶 Impeller Material: Metal  
工作方式 Operation mode: S1  
温度范围 Operating Temperature: -10°C~+65°C  
防护等级 Type of protection: IP44  
绝缘等级 Insulation class: "B"

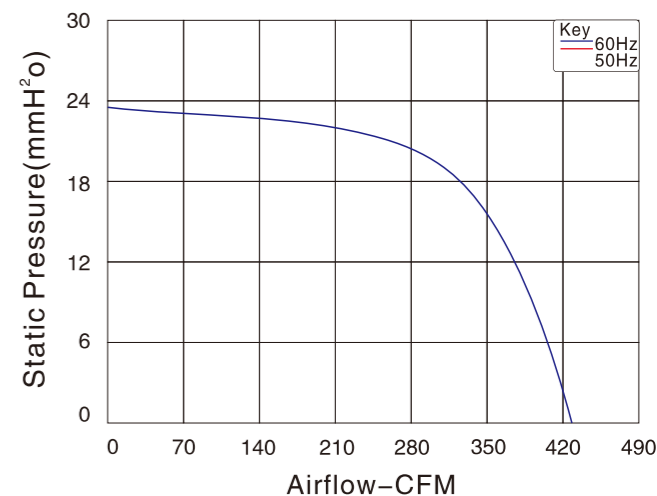

产品型号 Model	电压 Voltage VAC	频率 Freq. Hz	电流 Current A	功率 Power W	转速 Speed RPM	风量 Air Flow CFM	静压 Static Pressure mmH <sub>2</sub> O	噪音 Noise dB(A)
YES133BGA2-A01-W	230	50/60	0.75	108	1600	427.8	23.7	56.7

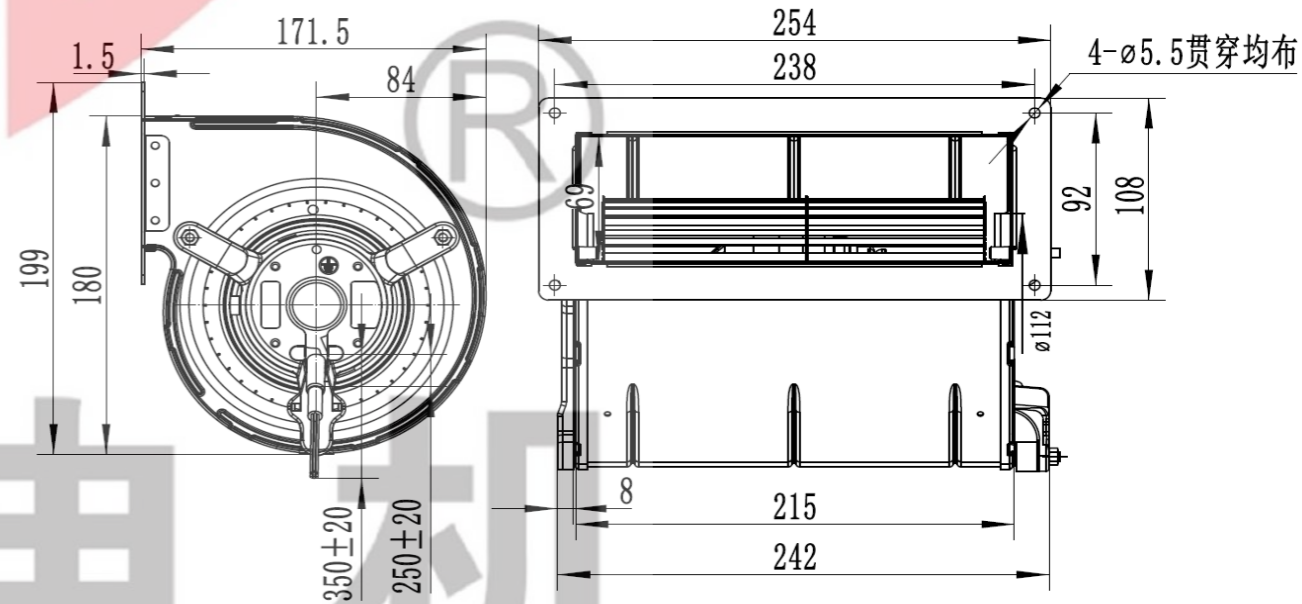

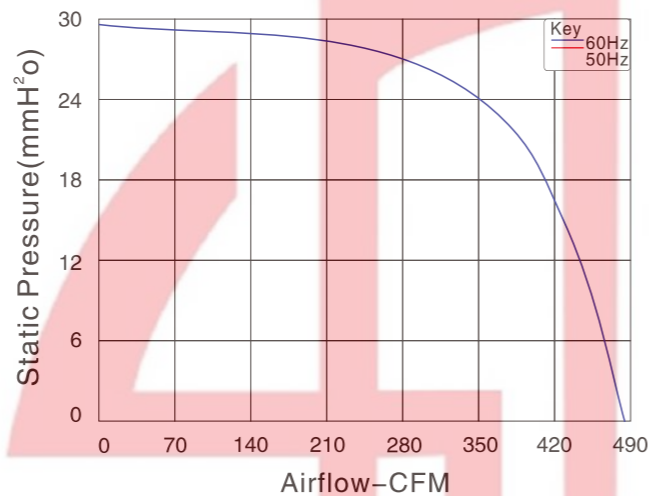

尺寸 Size: Ø133mmX190mm  
风量 Airflow: 481.3CFM  
噪音 Noise: 59.3dB(A)  
风叶 Impeller Material: Metal  
工作方式 Operation mode: S1  
温度范围 Operating Temperature: -10°C~+65°C  
防护等级 Type of protection: IP44  
绝缘等级 Insulation class: "B"

产品型号 Model	电压 Voltage VAC	频率 Freq. Hz	电流 Current A	功率 Power W	转速 Speed RPM	风量 Air Flow CFM	静压 Static Pressure mmH <sub>2</sub> O	噪音 Noise dB(A)
YES133BHA2-B01-W	230	50/60	0.8	158	1800	481.3	30	59.3

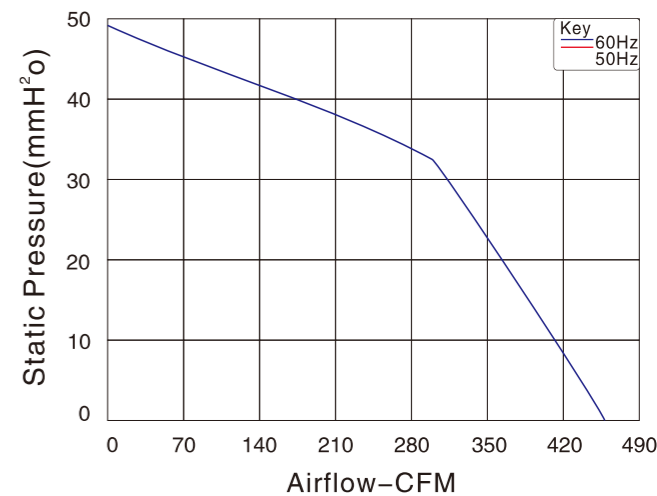
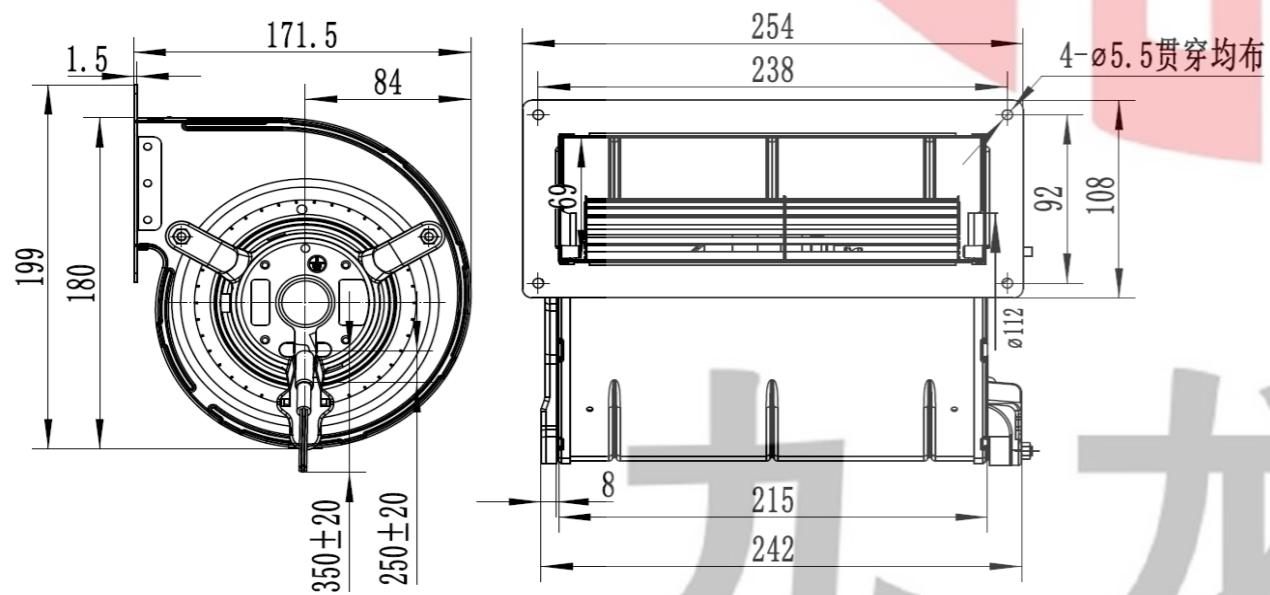

尺寸 Size: Ø146mmX150mm  
风量 Airflow: 459.6CFM  
噪音 Noise: 50.5dB(A)  
风叶 Impeller Material: PP  
工作方式 Operation mode: S1  
温度范围 Operating Temperature: -10°C~+65°C  
防护等级 Type of protection: IP44  
绝缘等级 Insulation class: "B"

产品型号 Model	电压 Voltage VAC	频率 Freq. Hz	电流 Current A	功率 Power W	转速 Speed RPM	风量 Air Flow CFM	静压 Static Pressure mmH <sub>2</sub> O	噪音 Noise dB(A)
YES146AGA2-B01-W	230	50/60	0.76	115	1600	459.6	49.6	50.5

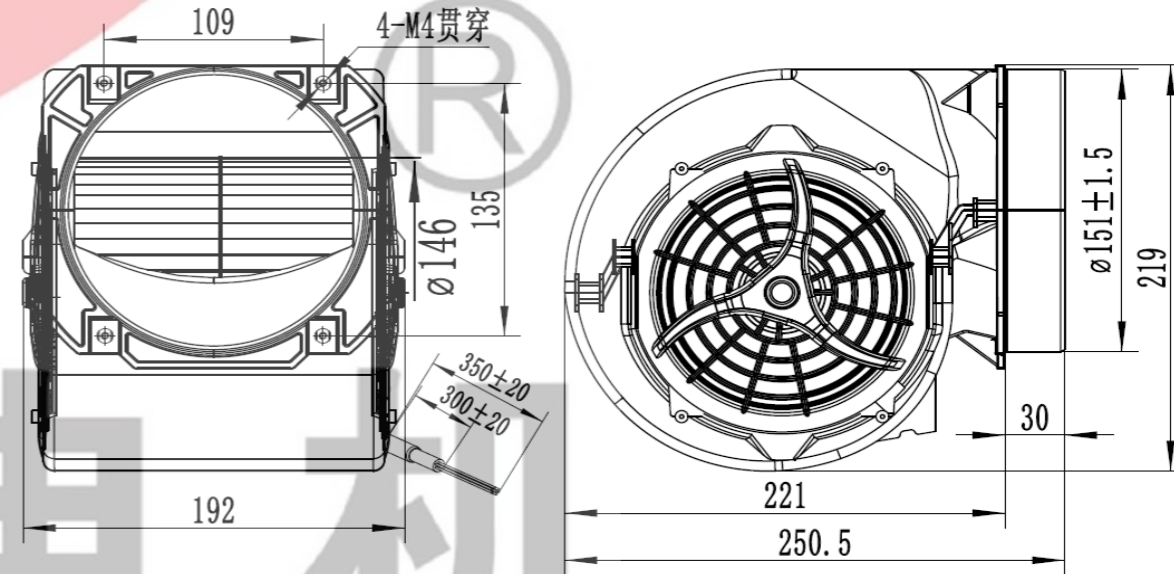

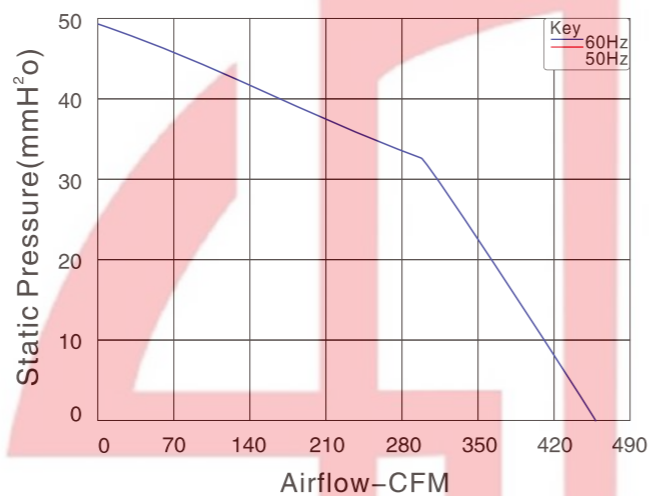

尺寸 Size: Ø146mmX150mm  
风量 Airflow: 671.2CFM  
噪音 Noise: 68dB(A)  
风叶 Impeller Material: PP  
工作方式 Operation mode: S1  
温度范围 Operating Temperature: -10°C~+65°C  
防护等级 Type of protection: IP44  
绝缘等级 Insulation class: "B"

产品型号 Model	电压 Voltage VAC	频率 Freq. Hz	电流 Current A	功率 Power W	转速 Speed RPM	风量 Air Flow CFM	静压 Static Pressure mmH <sub>2</sub> O	噪音 Noise dB(A)
YES146AHA2-A01-W	230	50/60	0.83	180	2000	671.2	45.9	68

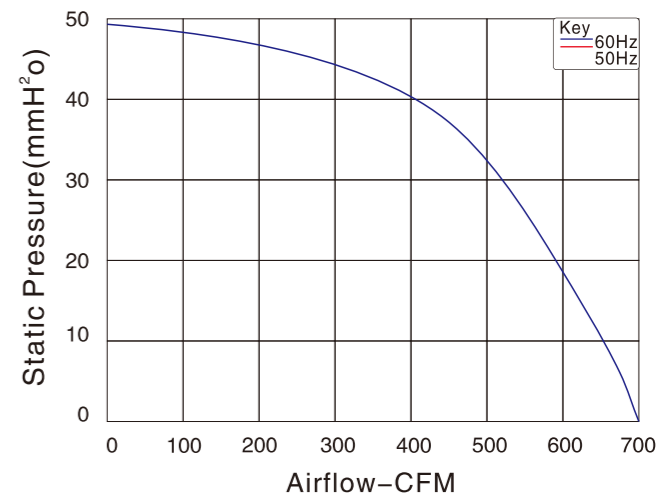
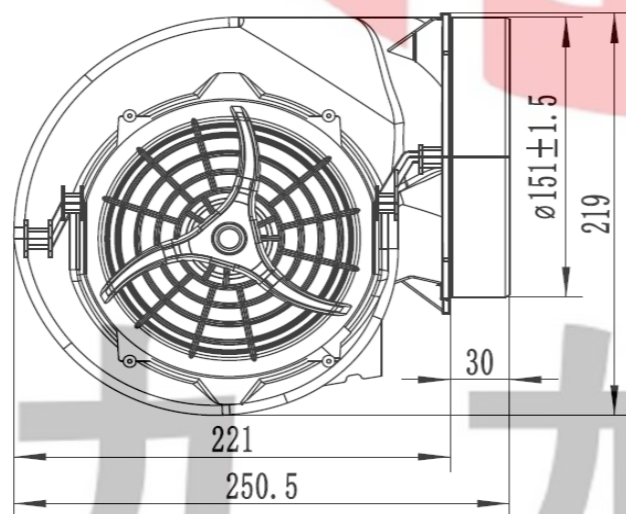
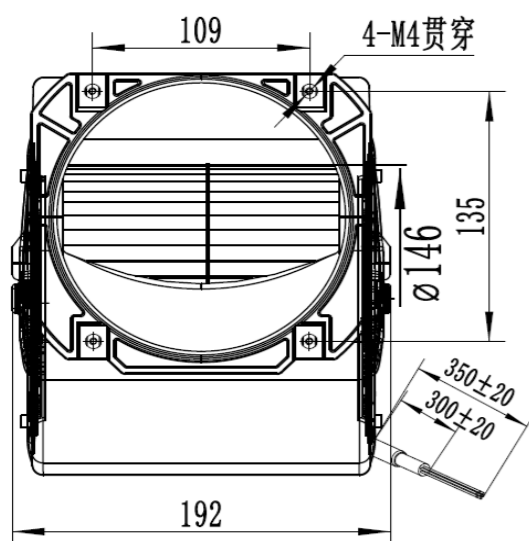

尺寸 Size: Ø146mmX190mm  
风量 Airflow: 700CFM  
噪音 Noise: 63.8dB(A)  
风叶 Impeller Material: Metal  
工作方式 Operation mode: S1  
温度范围 Operating Temperature: -10°C~+65°C  
防护等级 Type of protection: IP44  
绝缘等级 Insulation class: "B"

产品型号 Model	电压 Voltage VAC	频率 Freq. Hz	电流 Current A	功率 Power W	转速 Speed RPM	风量 Air Flow CFM	静压 Static Pressure mmH <sub>2</sub> O	噪音 Noise dB(A)
YES146BGA2-B01-W	230	50/60	0.9	170	1600	700	49.2	63.8

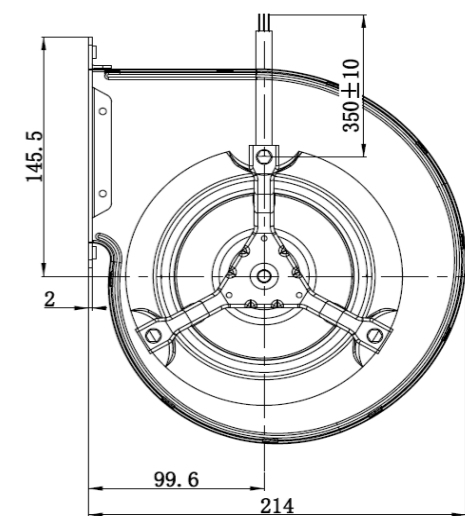
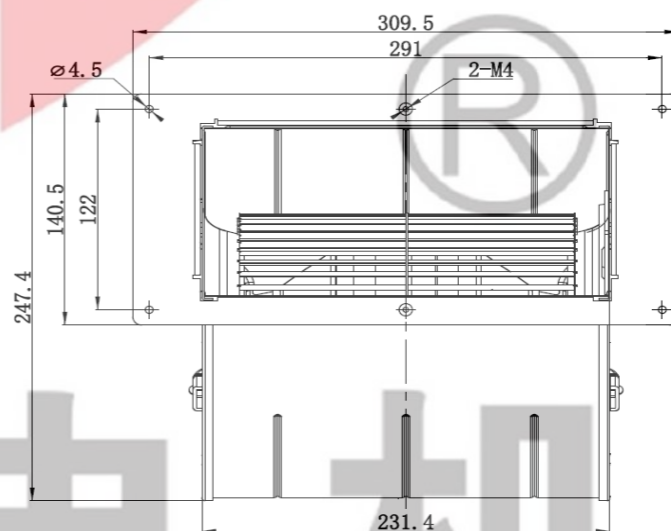

九 龙 电 机



JULONG MOTOR  
AC/DC FANS COOLING FANS



本样机仅供参考，具体以实物为准。  
This sample book is for reference only. Please refer to the specification for details.  
如需特殊电压也可单独定制提供。本公司保留技术更改权利。  
Special voltage may be provided (revised) according to the enquiry. All technical modification rights reserved.

Http://www.xtgygs.cn

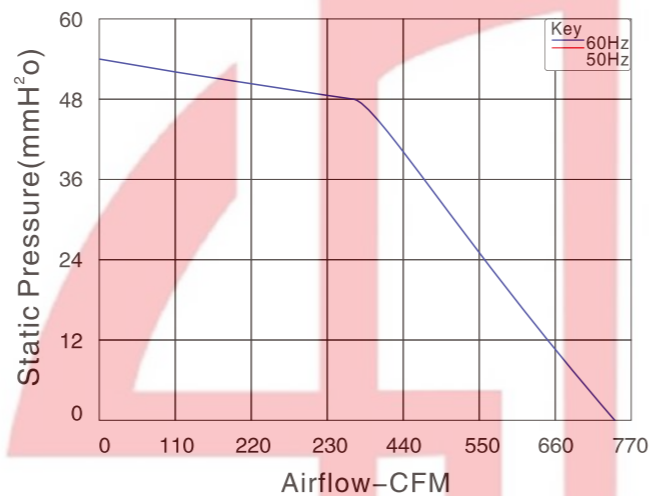

尺寸 Size: Ø146mmX190mm  
风量 Airflow: 742.8CFM  
噪音 Noise: 55.5dB(A)  
风叶 Impeller Material: Metal  
工作方式 Operation mode: S1  
温度范围 Operating Temperature: -10°C~+65°C  
防护等级 Type of protection: IP44  
绝缘等级 Insulation class: "B"

产品型号 Model	电压 Voltage VAC	频率 Freq. Hz	电流 Current A	功率 Power W	转速 Speed RPM	风量 Air Flow CFM	静压 Static Pressure mmH <sub>2</sub> O	噪音 Noise dB(A)
YES146BHA2-A01-W	230	50/60	1	200	1700	742.8	55.5	64.5

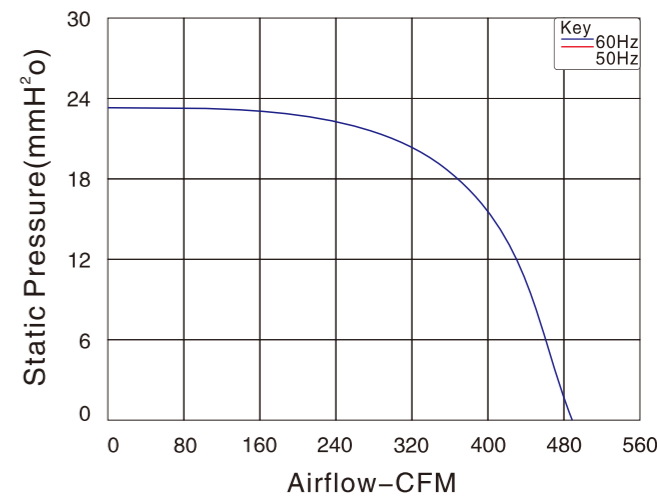
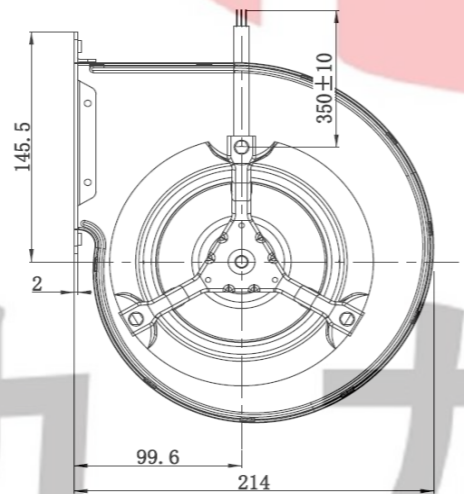
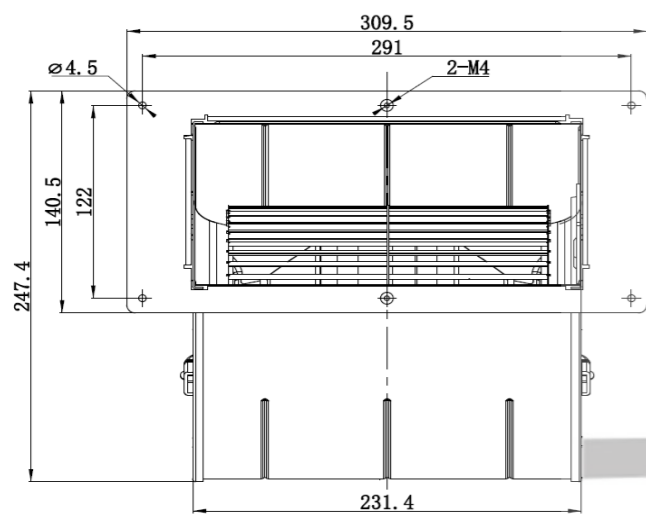

尺寸 Size: Ø151mmX195mm  
风量 Airflow: 481CFM  
噪音 Noise: 57.9dB(A)  
风叶 Impeller Material: Metal  
工作方式 Operation mode: S1  
温度范围 Operating Temperature: -10°C~+65°C  
防护等级 Type of protection: IP44  
绝缘等级 Insulation class: "B"

产品型号 Model	电压 Voltage VAC	频率 Freq. Hz	电流 Current A	功率 Power W	转速 Speed RPM	风量 Air Flow CFM	静压 Static Pressure mmH <sub>2</sub> O	噪音 Noise dB(A)
YES151AHA2-B01-W	230	50/60	0.54	118	1200	481	23	57.9

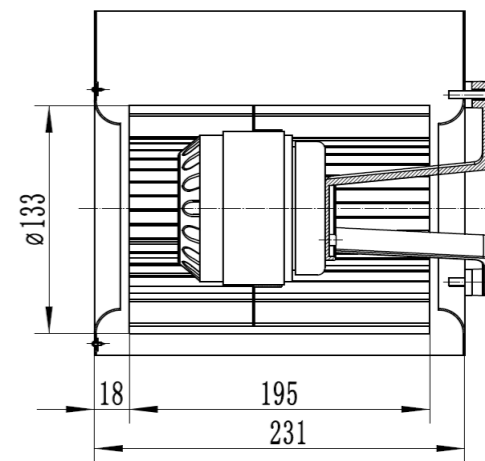
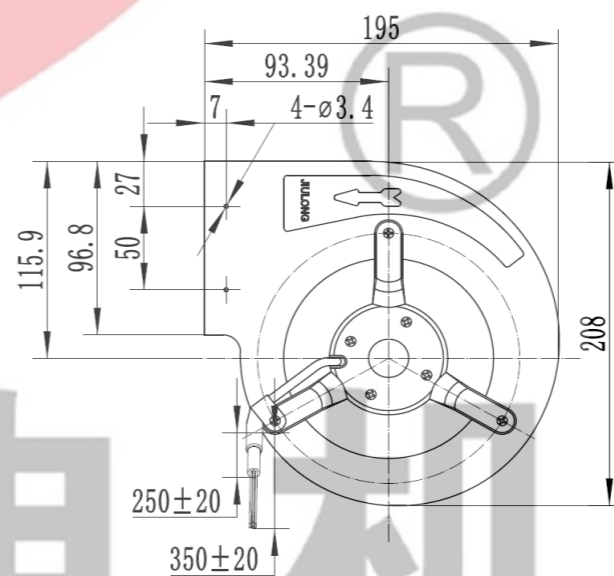

AC Axial Fan  
AC轴流风机

AC All-Metal Axial Fan  
AC全金属轴流风扇

DC Axial Fan  
DC轴流风机

DC Centrifugal Fan  
DC离心风机

EC Axial Fan  
EC轴流风机

EC Centrifugal Fan  
EC离心风机

AC Centrifugal Fan  
AC离心风机

Fan Accessories  
风机配件



JIULONG MOTOR  
AC/DC FANS COOLING FANS

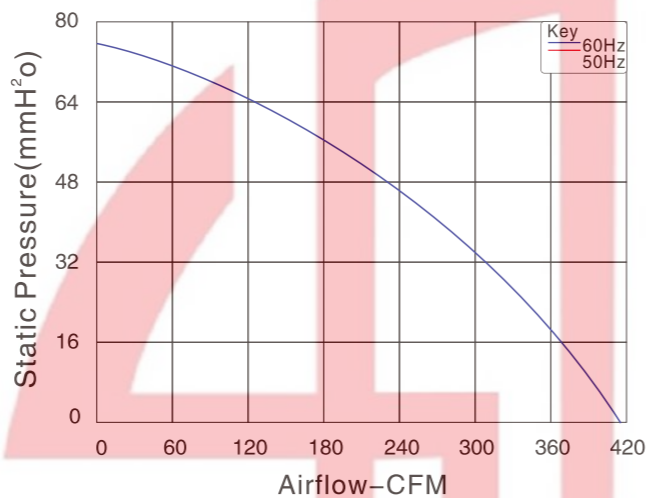

尺寸 Size: Ø160mmX75mm  
 风量 Airflow: 412.4CFM  
 噪音 Noise: 59.5dB(A)  
 风叶 Impeller Material: Metal  
 工作方式 Operation mode: S1  
 温度范围 Operating Temperature: -10°C~+65°C  
 防护等级 Type of protection: IP44  
 绝缘等级 Insulation class: "B"

产品型号 Model	电压 Voltage VAC	频率 Freq. Hz	电流 Current A	功率 Power W	转速 Speed RPM	风量 Air Flow CFM	静压 Static Pressure mmH <sub>2</sub> O	噪音 Noise dB(A)
YES160AHA2-B01-W	230	50/60	0.5	110	1400	412.4	75.4	59.5

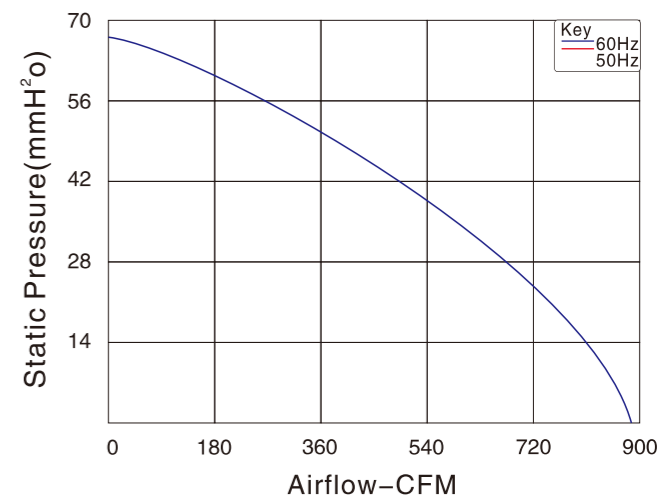

尺寸 Size: Ø160mmX250mm  
 风量 Airflow: 870CFM  
 噪音 Noise: 64dB(A)  
 风叶 Impeller Material: Metal  
 工作方式 Operation mode: S1  
 温度范围 Operating Temperature: -10°C~+65°C  
 防护等级 Type of protection: IP44  
 绝缘等级 Insulation class: "B"

产品型号 Model	电压 Voltage VAC	频率 Freq. Hz	电流 Current A	功率 Power W	转速 Speed RPM	风量 Air Flow CFM	静压 Static Pressure mmH <sub>2</sub> O	噪音 Noise dB(A)
YES160BIA2-A01-W	230	50/60	1.3	280	1400	870	68	64

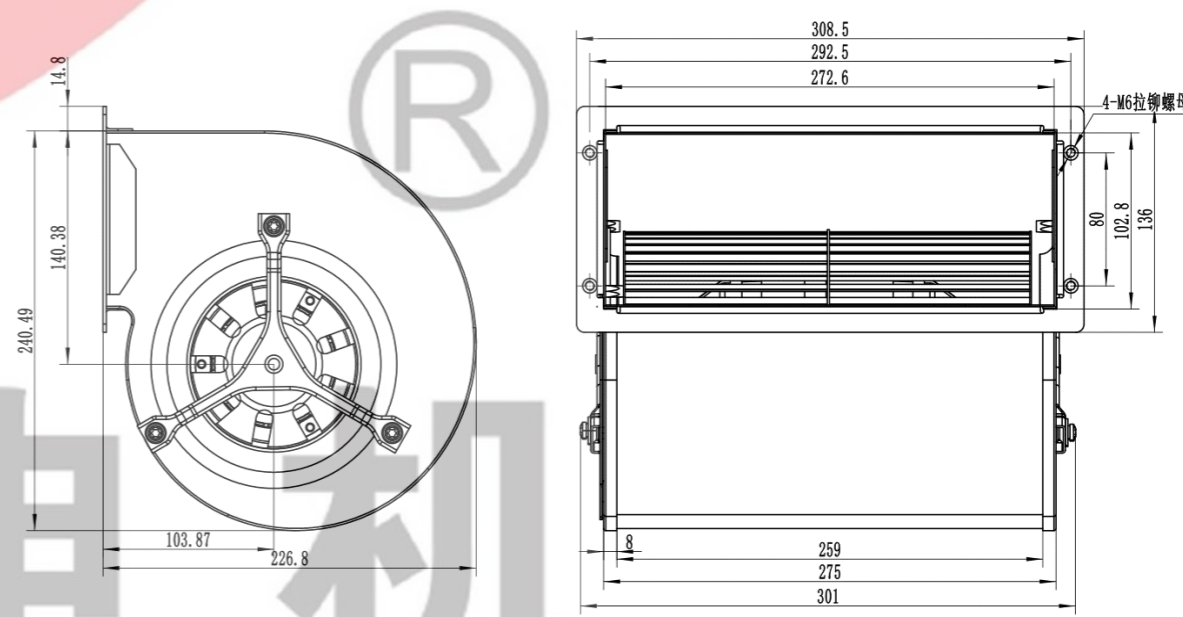
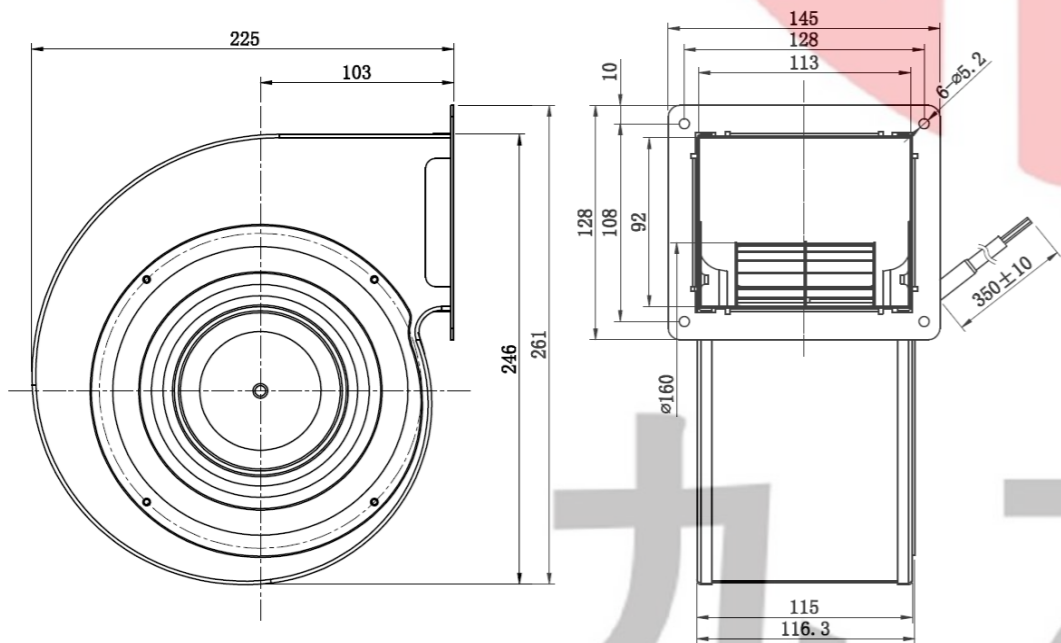

本样机仅供参考，具体以实物为准。  
 This sample book is for reference only, please refer to the specification for details.  
 如需特殊电压也可根据需要提供。本公司保留技术知识产权。  
 special voltage may be provided flexibly according to the enquiry, although technical modification is reserved.

Http://www.xtgygs.cn

# MODEL EXPLAIN

## 产品型号及结构图

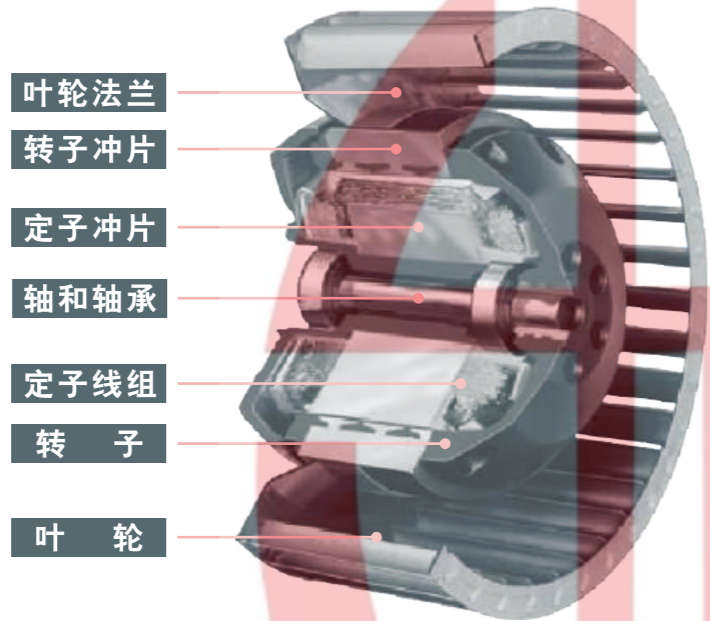

- 叶轮法兰
- 转子冲片
- 定子冲片
- 轴和轴承
- 定子线组
- 转 子
- 叶 轮

J H 225 A 2E 02 - W

- W: 蜗壳式Volute;
- 输入电压Input Voltage: A1: 115VAC;  
A2: 230VAC; A3、A4、A6: 380VAC
- 磁极数Magnetic Pole Number: 两极: 2E;  
四极: 4E; 六极: 6E. . . . .
- 设计序列号Design No.: A: No. 1; B: No. 2. . . . .
- 叶轮尺寸Impeller Size
- H: 后向式离心风机 Centrifugal fan backward curved;
- D: 单进口离心风机 Centrifugal fan single inlet
- S: 双进口离心风机 Centrifugal blower dual inlet
- G: 圆形管道风机 Circular duct fan
- 九龙风机Jiulong Fan

G 12038 H A2 B L-D

- D: 单法兰Single flange;
- C: 电容式Capacitor-Run AC;
- L: 引线式LEAD WIRE; T: 插座式;
- B: 滚珠轴承Ball Bearing;
- S: 含油轴承Sleeve Bearing;
- 输入电压Input Voltage: A1: 115VAC;  
A2: 230VAC; A3、A4、A6: 380VAC
- H: 高速High Speed; M: 中速Middle Speed;
- L: 低速Low Speed
- 外框尺寸Frame Size
- 九龙风机Jiulong Fan

# CONTENTS 目录

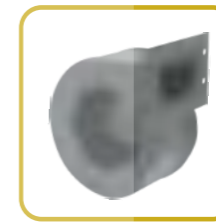

**289/299**  
**交流单进口离心风机**  
AC centrifugal fan single inlet

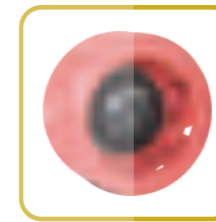

**300/319**  
**交流后向式离心风机**  
AC centrifugal fan backward curved



**320/329**  
**交流双进口离心风机**  
AC centrifugal blower dual inlet



**330/336**  
**交流圆形管道风机**  
AC circular duct fan

# 九龙电机

本样册仅做选型参考,具体以规格书为准。  
This sample book is for reference only. Please refer to the specification for details.  
如需特殊电压也可根据洽询提供, 本公司保留技术改动权利。  
Special voltage may be provided if necessary according to the inquiry. Jiulong all technical modification rights reserved.



JIULONG MOTOR  
AC/DC FANS COOLING FANS

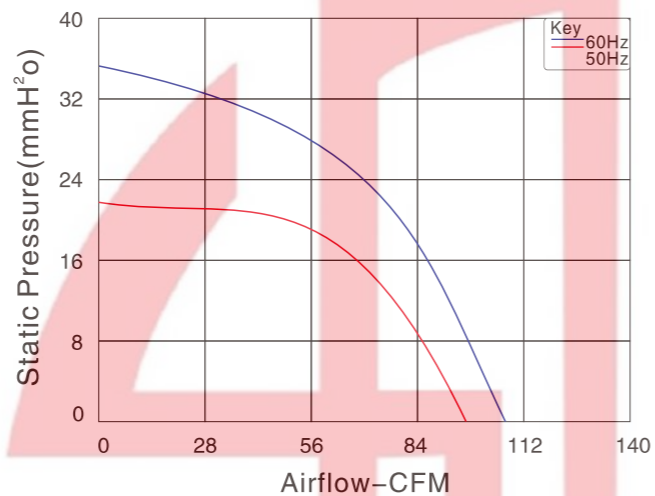

尺寸 Size: Ø108mm × 50mm  
重量 Weight: 1500g  
风叶 Impeller Material: Metal  
马达 Motor: Capacitor-Run And External Rotor Induction Motor  
引线 Lead Wire: Teflon 22# UL 1332(Optional)  
温度范围 Operating Temperature: -10°C~+65°C  
防护等级 Type of protection: IP20  
绝缘等级 Insulation class: "F"

产品型号 Model	电压 Voltage VAC	频率 Freq. Hz	电流 Current A	功率 Power W	转速 Speed RPM	噪音 Noise dBA	电容 Capacitor μF/VAC	风量 Air Flow CFM
JD108A2E02-W	230	50/60	0.18/0.25	33/35	1850/2200	56/59	1/500	94/105

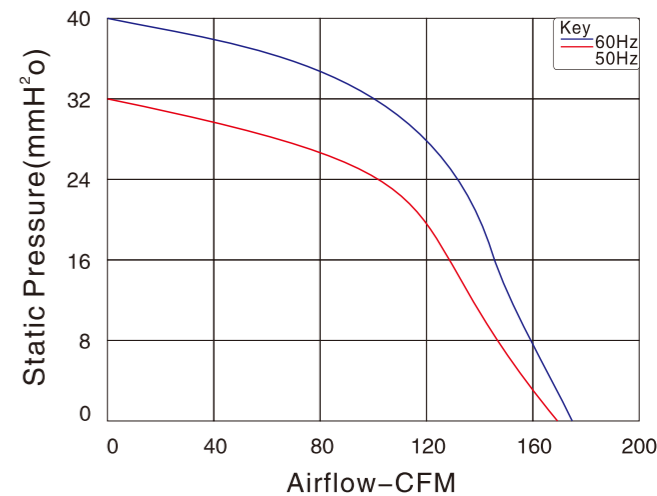
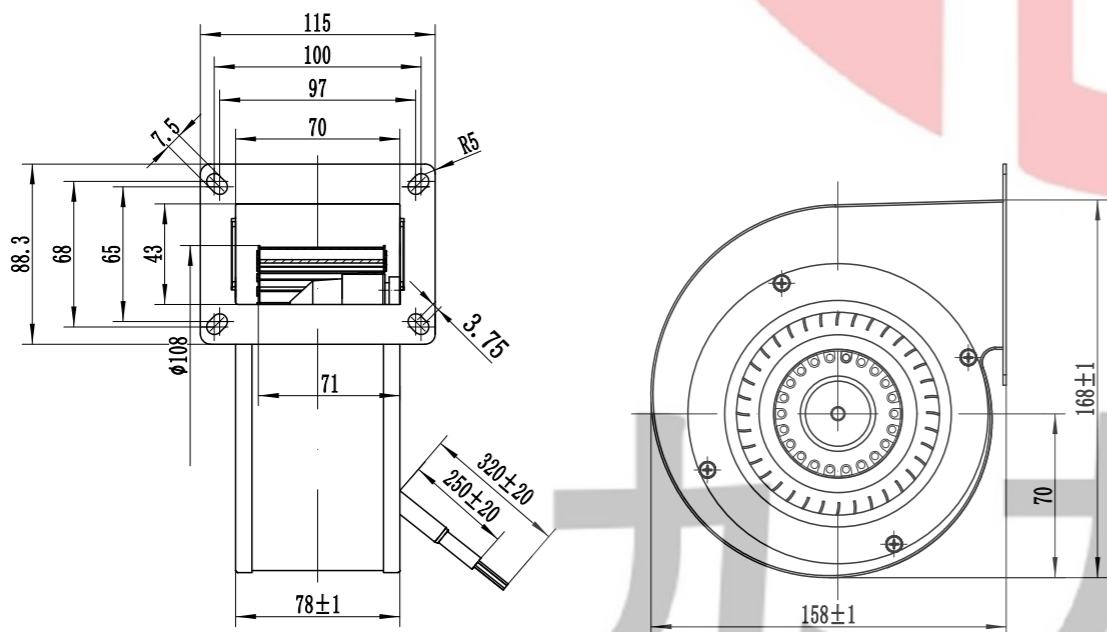

尺寸 Size: Ø120mm × 62mm  
重量 Weight: 2500g  
风叶 Impeller Material: Metal  
马达 Motor: Capacitor-Run And External Rotor Induction Motor  
引线 Lead Wire: Teflon 22# UL 1332(Optional)  
温度范围 Operating Temperature: -10°C~+65°C  
防护等级 Type of protection: IP44  
绝缘等级 Insulation class: "F"

产品型号 Model	电压 Voltage VAC	频率 Freq. Hz	电流 Current A	功率 Power W	转速 Speed RPM	噪音 Noise dBA	电容 Capacitor μF/VAC	风量 Air Flow CFM
JD120A2E01-W	115	50/60	0.7/0.8	76/95	2400/2500	56/60	8/250	178/185
JD120A2E02-W	230	50/60	0.42/0.48	80/100	2400/2500	56/60	2.2/500	178/185
JD120A2E03-W	380	50	0.3	105	2400	56	/	185
JD120A2E06-W	380	50	0.3	105	2400	56	1/500	185

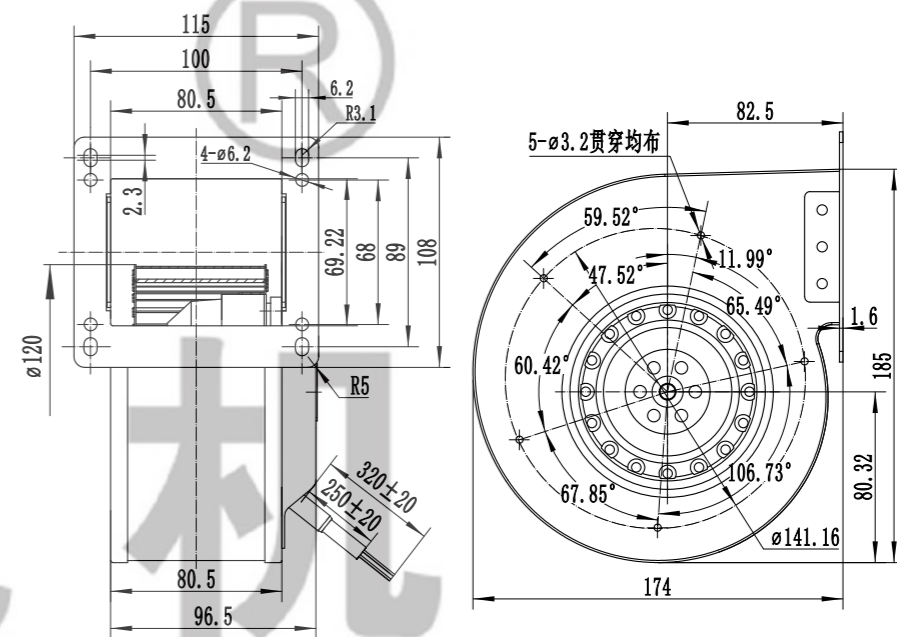

本样机仅供参考，具体以规格书为准。  
This sample book is for reference only, please refer to the specification for details.  
如需特殊电压也可根据规格书提供。本公司保留技术知识产权。  
Special voltage may be provided according to the enquiry, although technical modification is reserved.

Http://www.xtgygs.cn



JULONG MOTOR  
AC/DC FANS COOLING FANS



本样图仅供参考，具体以实物为准。  
This sample book is for reference only. Please refer to the specification for details.  
如需特殊电压也可根据需要提供。本公司保留技术更改权利。  
Special voltage may be provided if necessary according to the enquiry. All technical modification rights reserved.

Http://www.xtgygs.cn

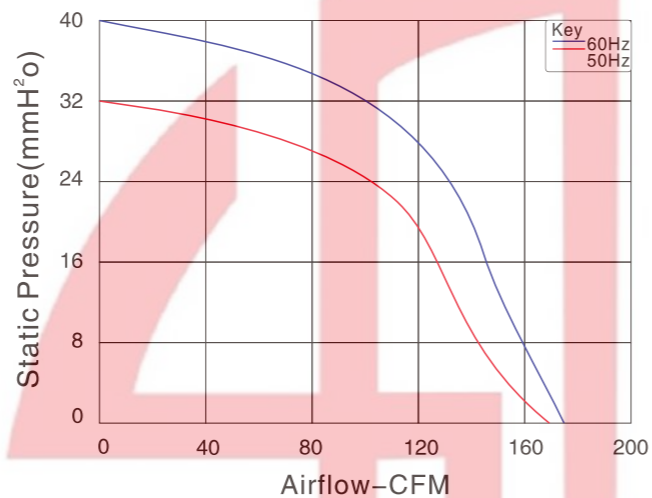

尺寸 Size: Ø120mm × 62mm  
重量 Weight: 2500g  
风叶 Impeller Material: Metal  
马达 Motor: Capacitor-Run And External Rotor Induction Motor  
引线 Lead Wire: Teflon 22# UL 1332(Optional)  
温度范围 Operating Temperature: -10°C~+65°C  
防护等级 Type of protection: IP44  
绝缘等级 Insulation class: "F"

产品型号 Model	电压 Voltage VAC	频率 Freq. Hz	电流 Current A	功率 Power W	转速 Speed RPM	噪音 Noise dB(A)	电容 Capacitor µF/VAC	风量 Air Flow CFM
JD120B2E01-W	115	50/60	0.7/0.8	80/90	2500/2600	56/60	8/250	178/185
JD120B2E02-W	230	50/60	0.42/0.48	80/100	2500/2600	56/60	2.2/630	178/185
JD120B2E03-W	380	50	0.3	105	2400	56	/	185
JD120B2E06-W	380	50	0.3	105	2400	56	1/630	185

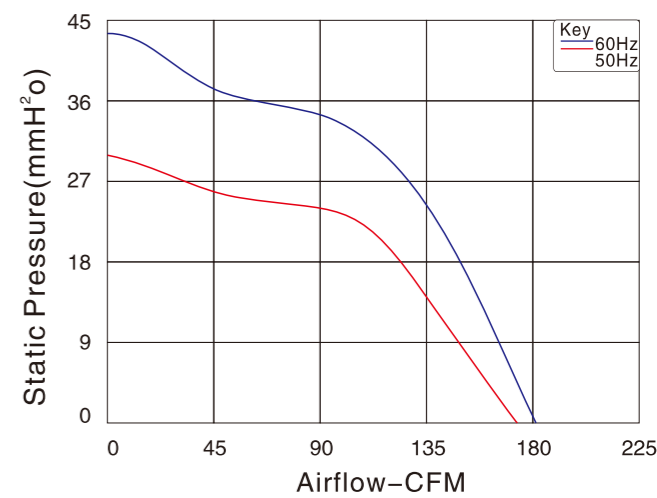
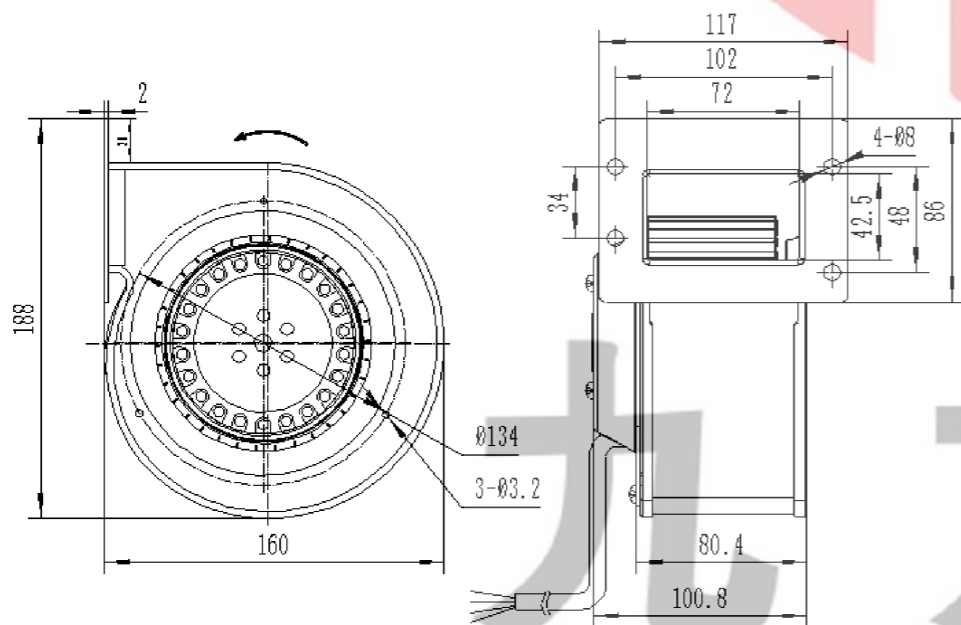

尺寸 Size: Ø133mm × 50mm  
重量 Weight: 2150g  
风叶 Impeller Material: Metal  
马达 Motor: Capacitor-Run And External Rotor Induction Motor  
引线 Lead Wire: Teflon 22# UL 1332(Optional)  
温度范围 Operating Temperature: -10°C~+65°C  
防护等级 Type of protection: IP44  
绝缘等级 Insulation class: "F"

产品型号 Model	电压 Voltage VAC	频率 Freq. Hz	电流 Current A	功率 Power W	转速 Speed RPM	噪音 Noise dB(A)	电容 Capacitor µF/VAC	风量 Air Flow CFM
JD133A2E01-W	115	50/60	0.55/0.7	78/100	2400/2600	62/64	8/250	160/170
JD133A2E02-W	230	50/60	0.45/0.55	80/100	2400/2600	62/64	2.2/500	160/170
JD133A2E03-W	380	50	0.15	40	2400	62	/	160

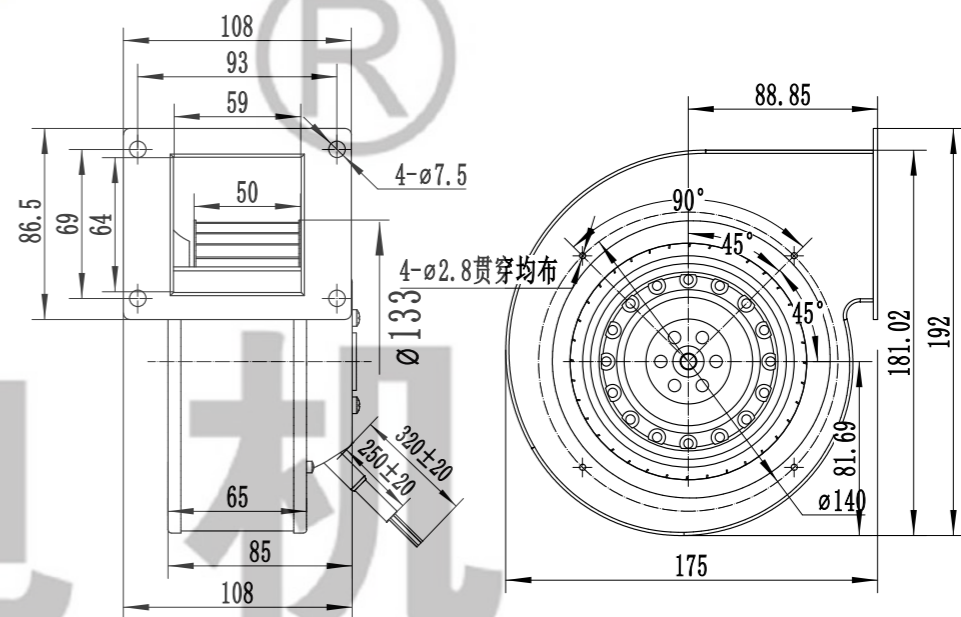

九 龙 电 机



本产品有正反蜗壳及叶轮可供选择

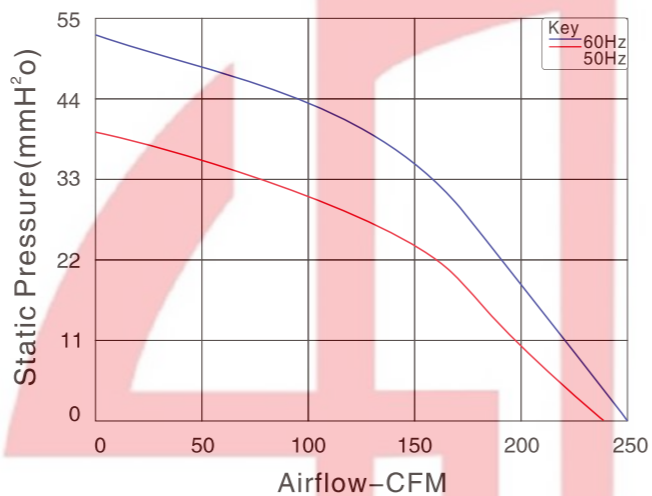

尺寸 Size: Ø133mm × 74mm  
重量 Weight: 2900g  
风叶 Impeller Material: Metal  
马达 Motor: Capacitor-Run And External Rotor Induction Motor  
引线 Lead Wire: Teflon 22# UL 1332(Optional)  
温度范围 Operating Temperature: -10°C~+65°C  
防护等级 Type of protection: IP44  
绝缘等级 Insulation class: "F"

产品型号 Model	电压 Voltage VAC	频率 Freq. Hz	电流 Current A	功率 Power W	转速 Speed RPM	噪音 Noise dB(A)	电容 Capacitor µF/VAC	风量 Air Flow CFM
JD133B2E01-W	110	50/60	1.5/1.7	140/170	2550/2750	61/63	10/500	240/250
JD133B2E02-W	230	50/60	0.5/0.6	110/130	2550/2750	61/63	4/500	240/230

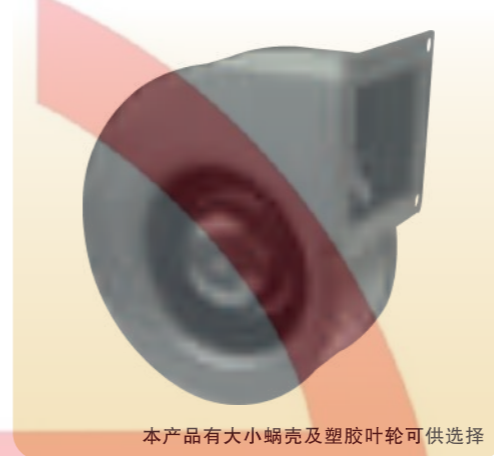
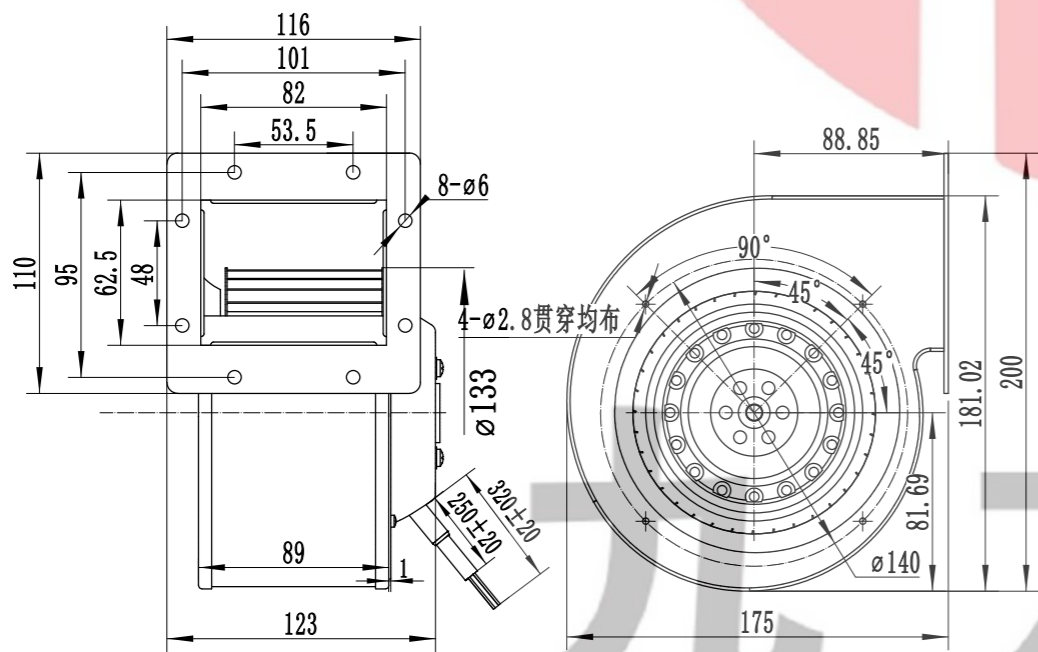

本产品有大小蜗壳及塑胶叶轮可供选择

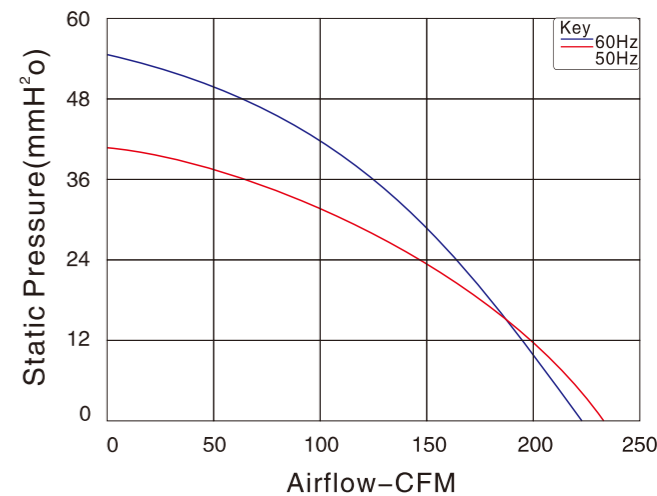

尺寸 Size: Ø140mm × 61mm  
重量 Weight: 3500g  
风叶 Impeller Material: Metal  
马达 Motor: Capacitor-Run And External Rotor Induction Motor  
引线 Lead Wire: Teflon 22# UL 1332(Optional)  
温度范围 Operating Temperature: -10°C~+65°C  
防护等级 Type of protection: IP44  
绝缘等级 Insulation class: "F"

产品型号 Model	电压 Voltage VAC	频率 Freq. Hz	电流 Current A	功率 Power W	转速 Speed RPM	噪音 Noise dB(A)	电容 Capacitor µF/VAC	风量 Air Flow CFM
JD140A2E02-W	230	50/60	0.52/0.56	160/190	1750/1610	60/59	4/500	234/220

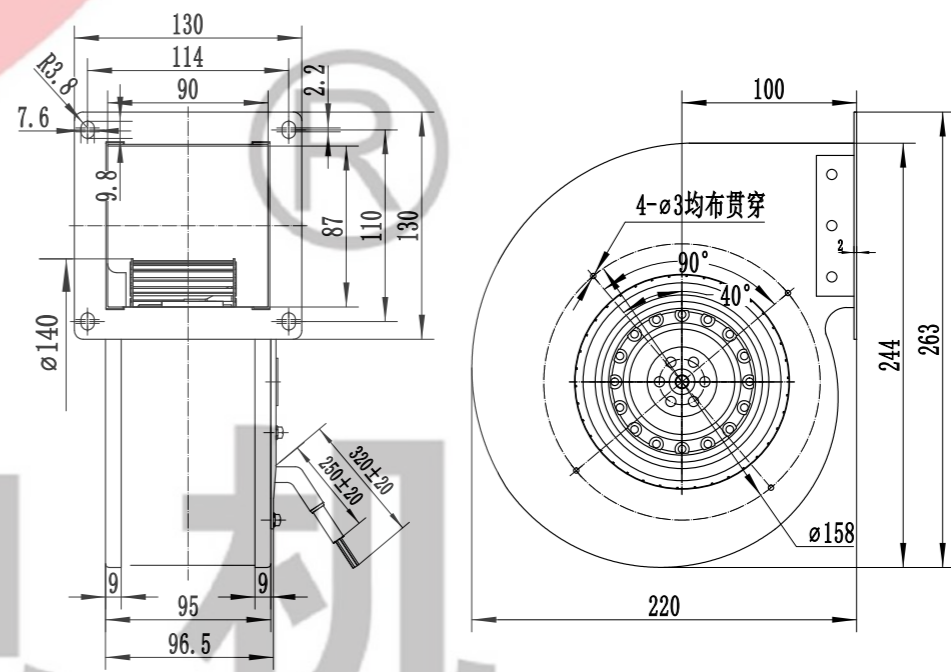

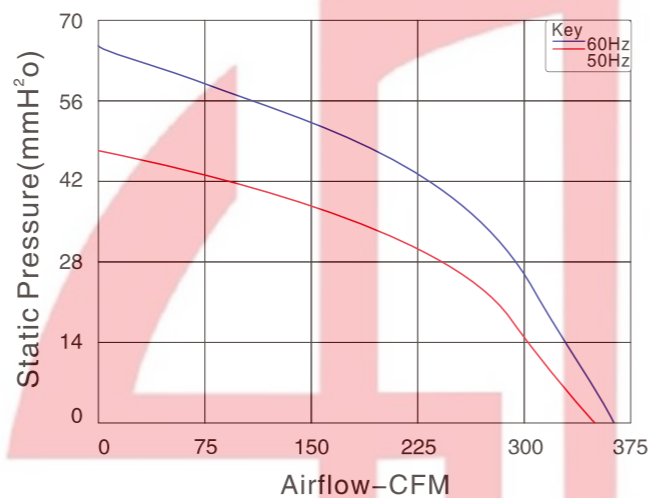

尺寸 Size: Ø150mm × 72mm  
重量 Weight: 3300g  
风叶 Impeller Material: Metal  
马达 Motor: Capacitor-Run And External Rotor Induction Motor  
引线 Lead Wire: Teflon 22# UL 1332(Optional)  
温度范围 Operating Temperature: -10°C~+65°C  
防护等级 Type of protection: IP44  
绝缘等级 Insulation class: "F"

产品型号 Model	电压 Voltage VAC	频率 Freq. Hz	电流 Current A	功率 Power W	转速 Speed RPM	噪音 Noise dB(A)	电容 Capacitor µF/VAC	风量 Air Flow CFM
JD150A2E01-W	115	50/60	1.68/2.0	180/220	2400/2500	68/70	20/250	335/350
JD150A2E02-W	230	50/60	0.68/0.9	150/200	2400/2500	68/70	4/500	335/350
JD150A2E03-W	380	50/60	1.1/1.2	132/246	2400/2500	68/70	4/500	335/350

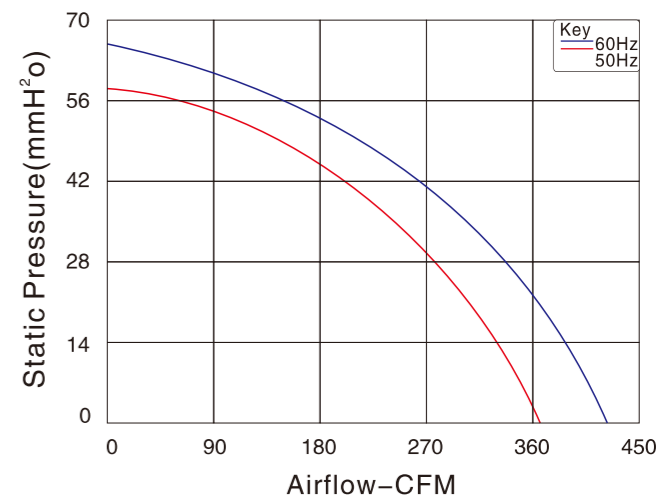
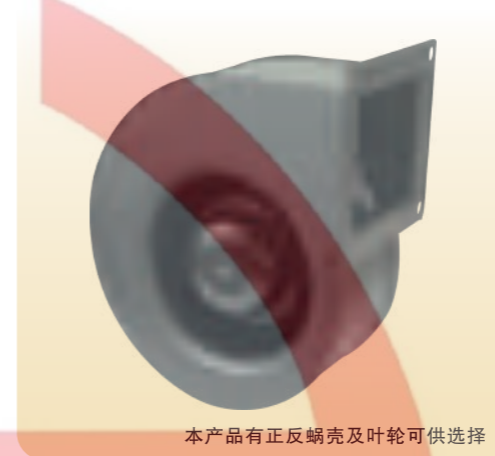
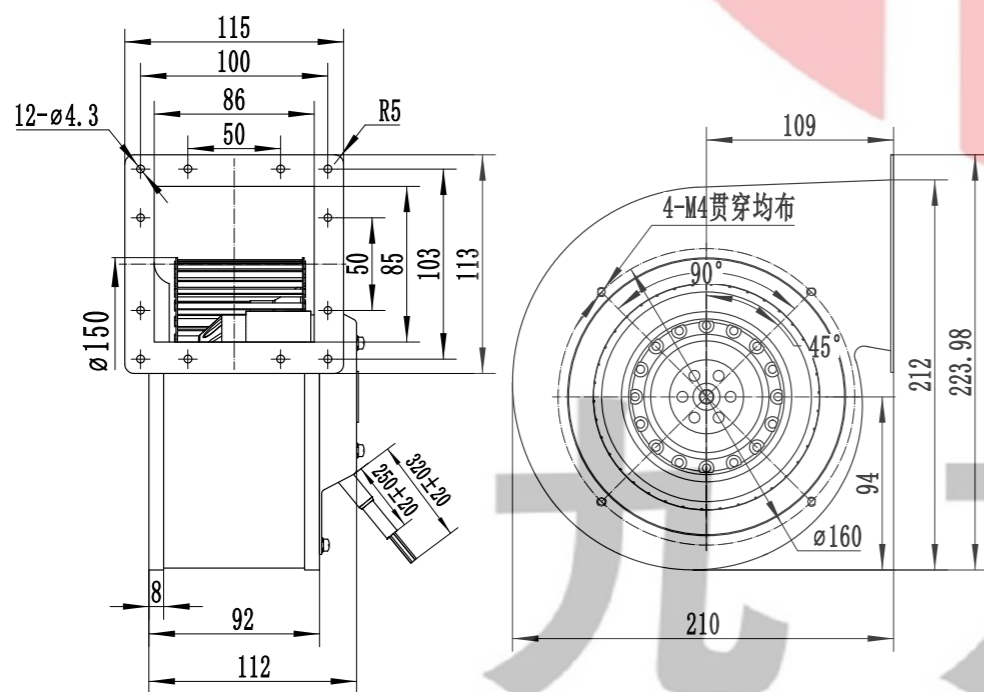

尺寸 Size: Ø160mm × 61mm  
重量 Weight: 3500g  
风叶 Impeller Material: Metal  
马达 Motor: Capacitor-Run And External Rotor Induction Motor  
引线 Lead Wire: Teflon 22# UL 1332(Optional)  
温度范围 Operating Temperature: -10°C~+65°C  
防护等级 Type of protection: IP44  
绝缘等级 Insulation class: "F"

产品型号 Model	电压 Voltage VAC	频率 Freq. Hz	电流 Current A	功率 Power W	转速 Speed RPM	噪音 Noise dB(A)	电容 Capacitor µF/VAC	风量 Air Flow CFM
JD160A2E01-W	115	50/60	1.3/1.57	170/207	1800/2200	65/68	20/250	363/424
JD160A2E02-W	230	50/60	0.63/0.73	130/175	1800/2200	65/68	4/630	363/424

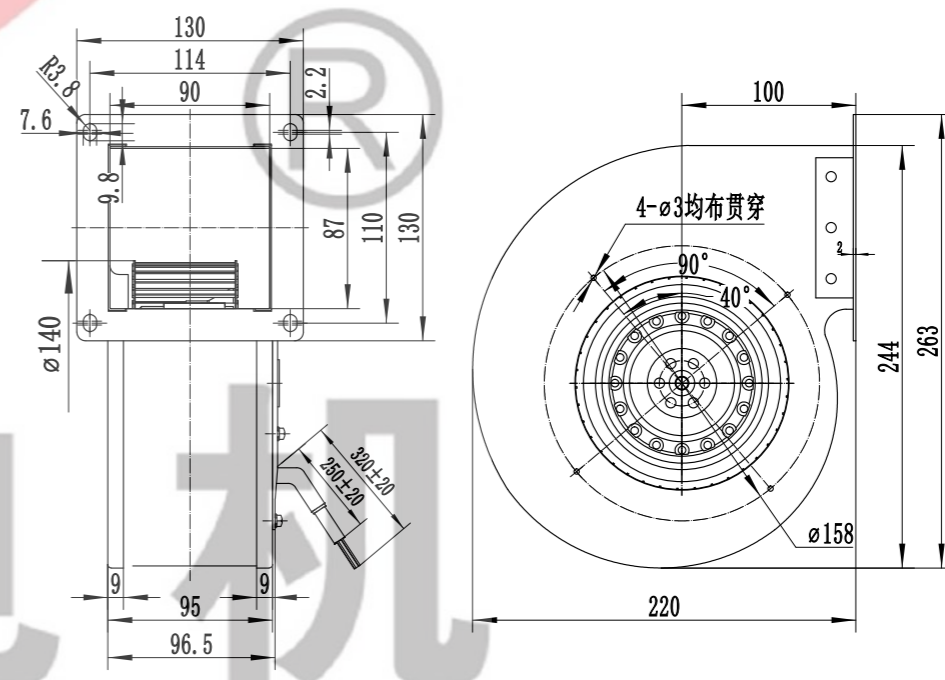



JULONG MOTOR  
AC/DC FANS COOLING FANS

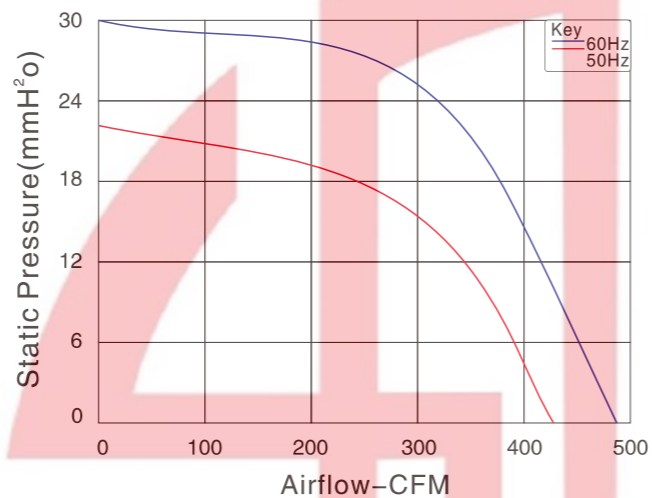

尺寸 Size: Ø180mm × 92mm  
重量 Weight: 5100g  
风叶 Impeller Material: Metal  
马达 Motor: Capacitor-Run And External Rotor Induction Motor  
引线 Lead Wire: Teflon 22# UL 1332(Optional)  
温度范围 Operating Temperature: -10°C~+65°C  
防护等级 Type of protection: IP44  
绝缘等级 Insulation class: "F"

产品型号 Model	电压 Voltage VAC	频率 Freq. Hz	电流 Current A	功率 Power W	转速 Speed RPM	噪音 Noise dB(A)	电容 Capacitor μF/VAC	风量 Air Flow CFM
JD180A4E01-W	115	50/60	1.7/1.4	130/160	1350/1550	65/67	20/450	426/471
JD180A4E02-W	230	50/60	0.6/0.9	135/180	1350/1550	65/67	5/500	426/471
JD180A4E03-W	380	50	0.3/0.25	135/155	1350/1550	65/67	/	426/471

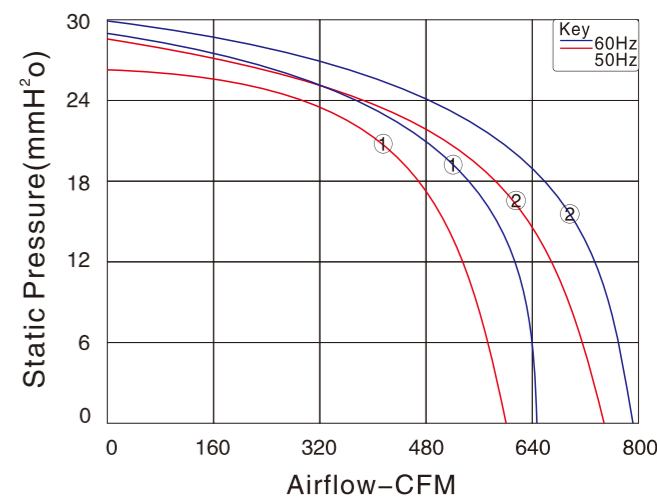
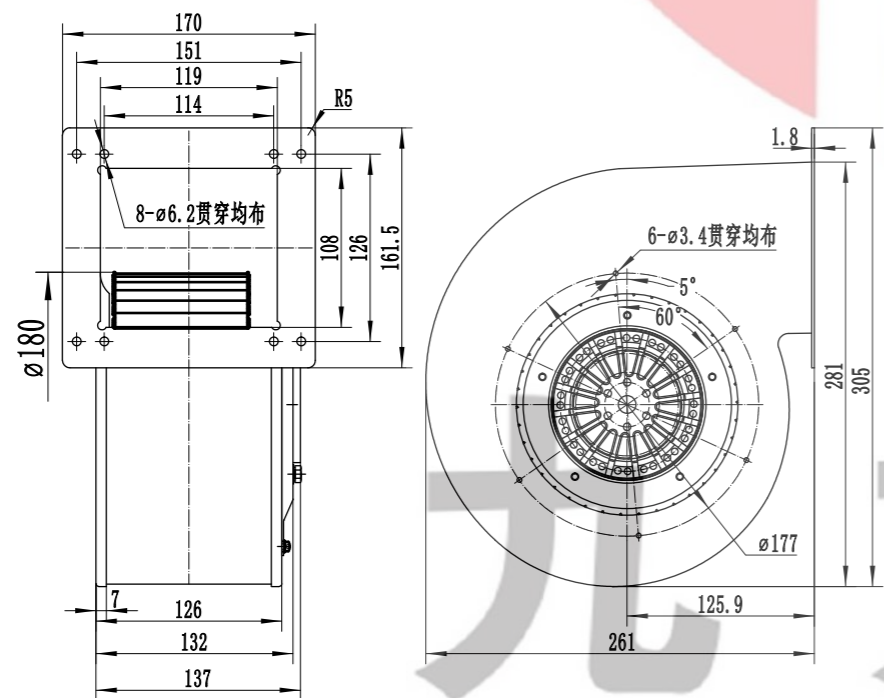

尺寸 Size: Ø200mm × 54/81/104mm  
重量 Weight: 2500g  
风叶 Impeller Material: Metal  
马达 Motor: Capacitor-Run And External Rotor Induction Motor  
引线 Lead Wire: Teflon 22# UL 1332(Optional)  
温度范围 Operating Temperature: -10°C~+65°C  
防护等级 Type of protection: IP44  
绝缘等级 Insulation class: "F"

产品型号 Model	电压 Voltage VAC	频率 Freq. Hz	电流 Current A	功率 Power W	转速 Speed RPM	噪音 Noise dB(A)	电容 Capacitor μF/VAC	风量 Air Flow CFM
JD200A4E01 ①	115	50/60	0.9/1.1	110/120	1300/1500	58/62	20/250	589/648
JD200A4E02 ①	230	50/60	0.4/0.5	85/100	1300/1500	58/62	4/630	589/648
JD200B4E01 ②	115	60	0.9	110	1300	53	20/250	719
JD200B4E02 ②	230	50/60	0.5/0.65	110/120	1300/1500	53/57	4/630	719/795

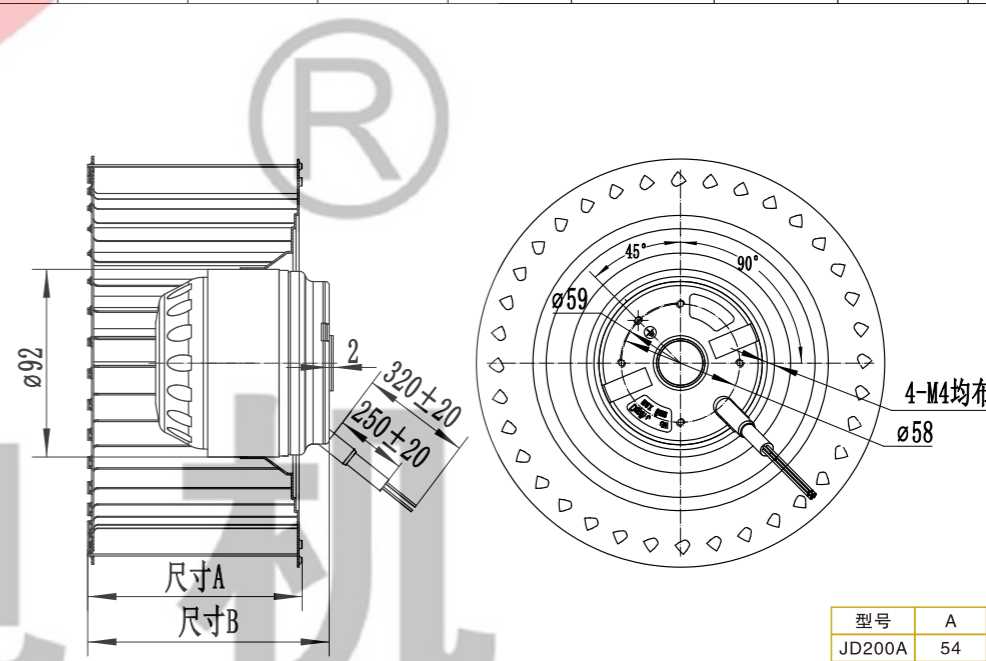

型号	A	B
JD200A	54	81
JD200B	81	94.5



JULONG MOTOR  
AC/DC FANS COOLING FANS



本样图仅供参考，具体以实物为准。  
This sample book is for reference only, please refer to the specification for details.  
如需特殊电压也可根据需求提供，本公司保留技术知识产权。  
Special voltage may be provided flexibly according to the requirement, although technical modification is reserved.

Http://www.xtgygs.cn



本产品Ø102电机可供选择

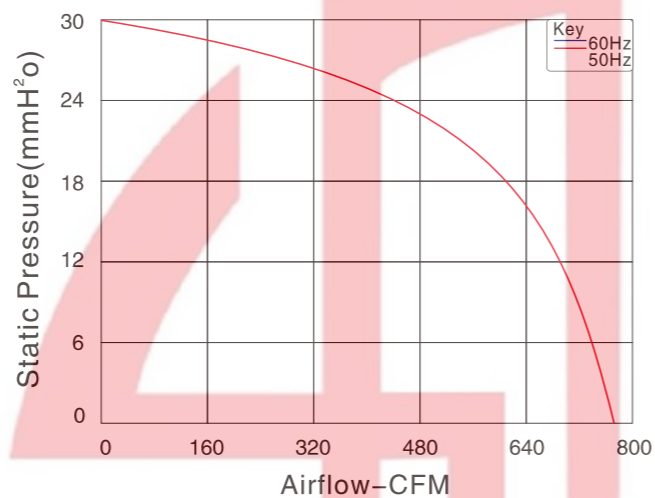

尺寸 Size: Ø200mm × 54/81/104mm  
重量 Weight: 2500g  
风叶 Impeller Material: Metal  
马达 Motor: Capacitor-Run And External Rotor Induction Motor  
引线 Lead Wire: Teflon 22# UL 1332(Optional)  
温度范围 Operating Temperature: -10°C~+65°C  
防护等级 Type of protection: IP44  
绝缘等级 Insulation class: "F"

产品型号 Model	电压 Voltage VAC	频率 Freq. Hz	电流 Current A	功率 Power W	转速 Speed RPM	噪音 Noise dB(A)	电容 Capacitor µF/VAC	风量 Air Flow CFM
JD200C4E02	230	50	0.9	190	1350	53	5/630	795
JD200C4E06	380	50	0.5	190	1350	53	/	795

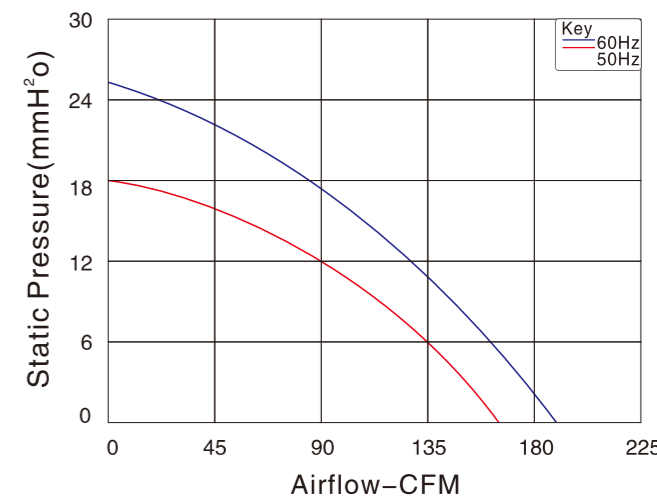
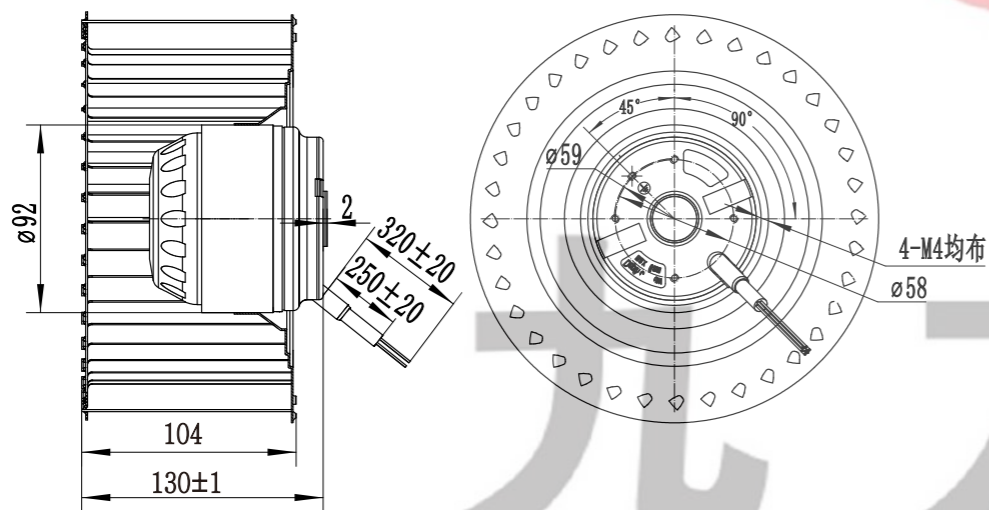

尺寸 Size: Ø133mm × 61mm  
重量 Weight: 800g  
风叶 Impeller Material: PA66  
马达 Motor: Shaded Pole And External Rotor Induction Motor  
引线 Lead Wire: Teflon 22# UL 1332(Optional)  
温度范围 Operating Temperature: -10°C~+65°C  
防护等级 Type of protection: IP22  
绝缘等级 Insulation class: "F"

产品型号 Model	电压 Voltage VAC	频率 Freq. Hz	电流 Current A	功率 Power W	转速 Speed RPM	噪音 Noise dB(A)	电容 Capacitor µF/VAC	风量 Air Flow CFM
JH133A2E01	115	50/60	0.55/0.48	42/40	2750/3000	54/57	/	165/188
JH133A2E02	230	50/60	0.3/0.26	42/40	2750/3000	54/57	/	165/188

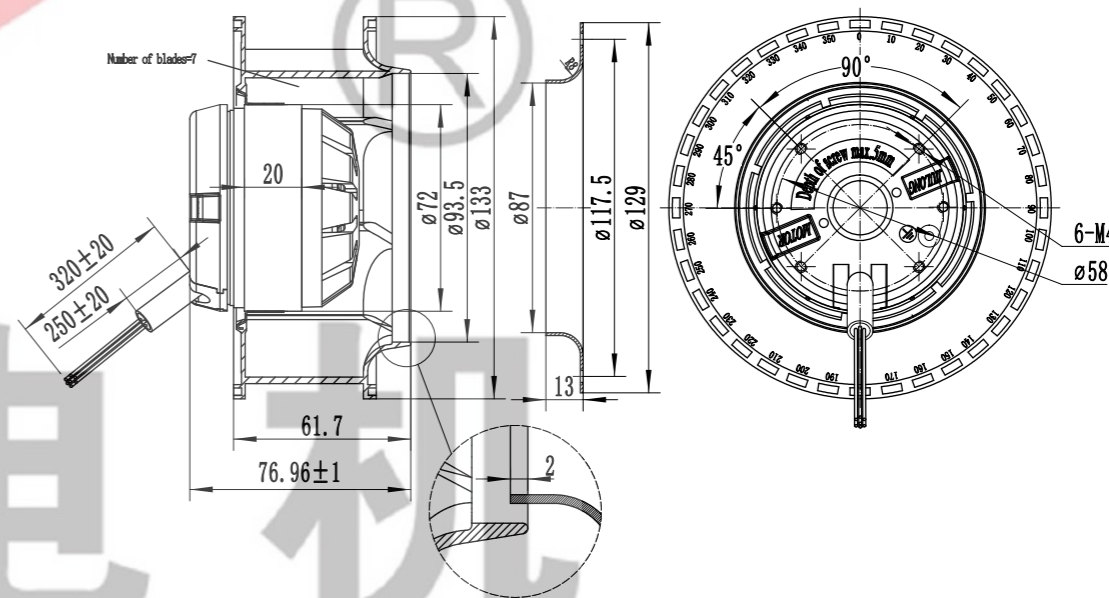

九 龙 电 机

AC Axial Fan  
AC轴流风机

AC All-Metal Axial Fan  
AC全金属轴流风扇

DC Axial Fan  
DC轴流风机

DC Centrifugal Fan  
DC离心风机

EC Axial Fan  
EC轴流风机

EC Centrifugal Fan  
EC离心风机

AC Centrifugal Fan  
AC离心风机

Fan Accessories  
风机配件



JULONG MOTOR  
AC/DC FANS COOLING FANS



本样图仅供参考，具体以实物为准。  
This sample book is for reference only, please refer to the specification for details.  
如需特殊电压也可根据需求提供，本公司保留技术改动权利。  
Special voltage may be provided according to the requirement, although technical modification rights reserved.

Http://www.xtgygs.cn

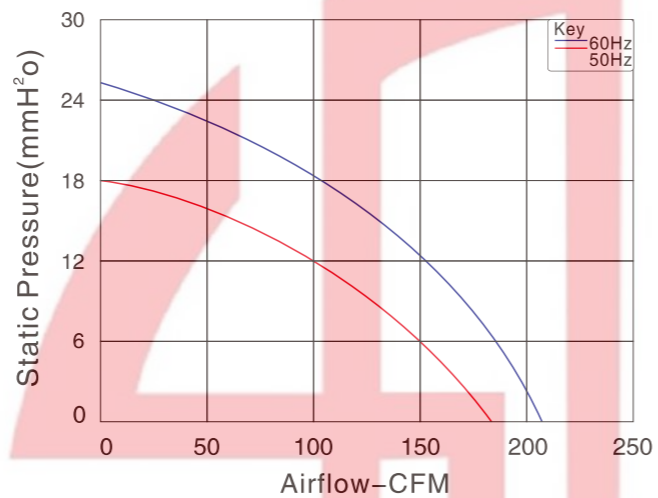

尺寸 Size: Ø133mm × 61mm  
重量 Weight: 800g  
风叶 Impeller Material: PA66  
马达 Motor: Capacitor-Run And External Rotor Induction Motor  
引线 Lead Wire: Teflon 22# UL 1332(Optional)  
温度范围 Operating Temperature: -10°C~+65°C  
防护等级 Type of protection: IP44  
绝缘等级 Insulation class: "F"

产品型号 Model	电压 Voltage VAC	频率 Freq. Hz	电流 Current A	功率 Power W	转速 Speed RPM	噪音 Noise dB(A)	电容 Capacitor μF/VAC	风量 Air Flow CFM
JH133B2E01	115	50/60	0.34/0.3	35/33	2600/3100	51/56	3.3/500	171/203
JH133B2E02	230	50/60	0.15/0.13	33/30	2600/3100	51/56	1/500	171/203

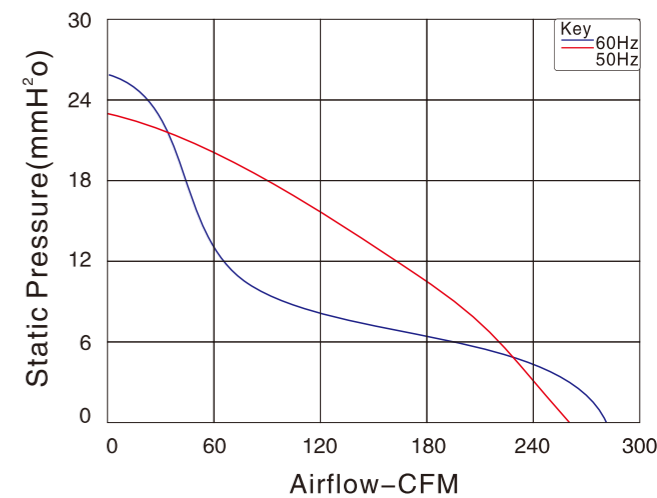
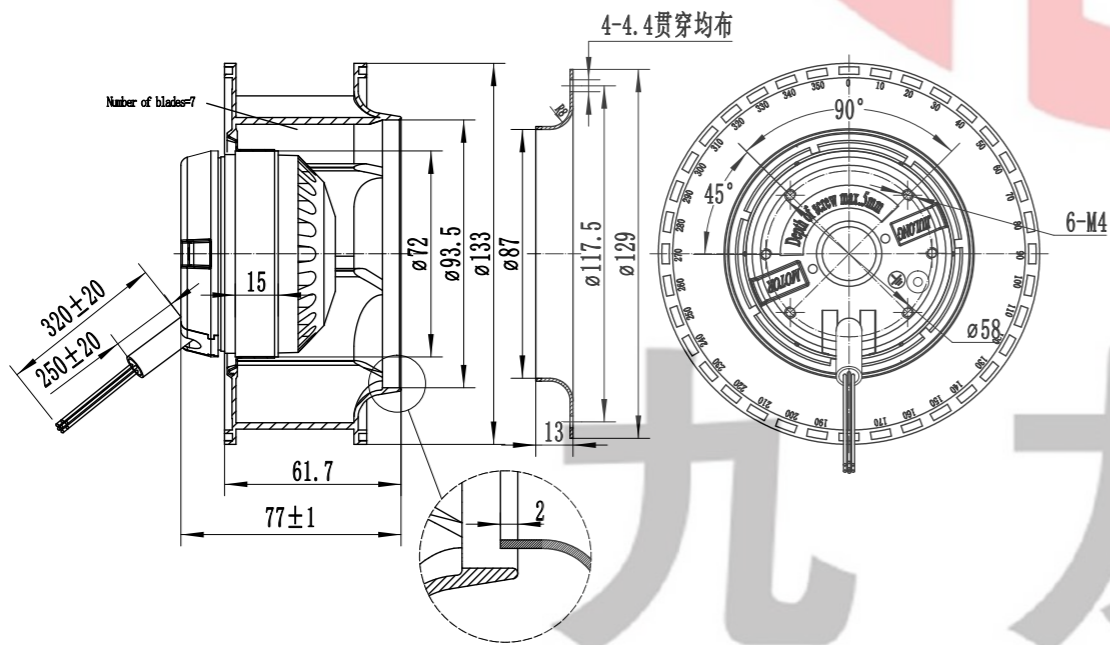

尺寸 Size: Ø175mm × 61mm  
重量 Weight: 1000g  
风叶 Impeller Material: PA66  
马达 Motor: Shaded Pole And External Rotor Induction Motor  
引线 Lead Wire: Teflon 22# UL 1332(Optional)  
温度范围 Operating Temperature: -10°C~+65°C  
防护等级 Type of protection: IP20  
绝缘等级 Insulation class: "F"

产品型号 Model	电压 Voltage VAC	频率 Freq. Hz	电流 Current A	功率 Power W	转速 Speed RPM	噪音 Noise dB(A)	电容 Capacitor μF/VAC	风量 Air Flow CFM
JH175A2E01	115	50/60	0.6/0.5	55/53	2400/2350	60/59	/	259/269
JH175A2E02	230	50/60	0.36/0.42	55/53	2400/2350	60/59	/	259/269

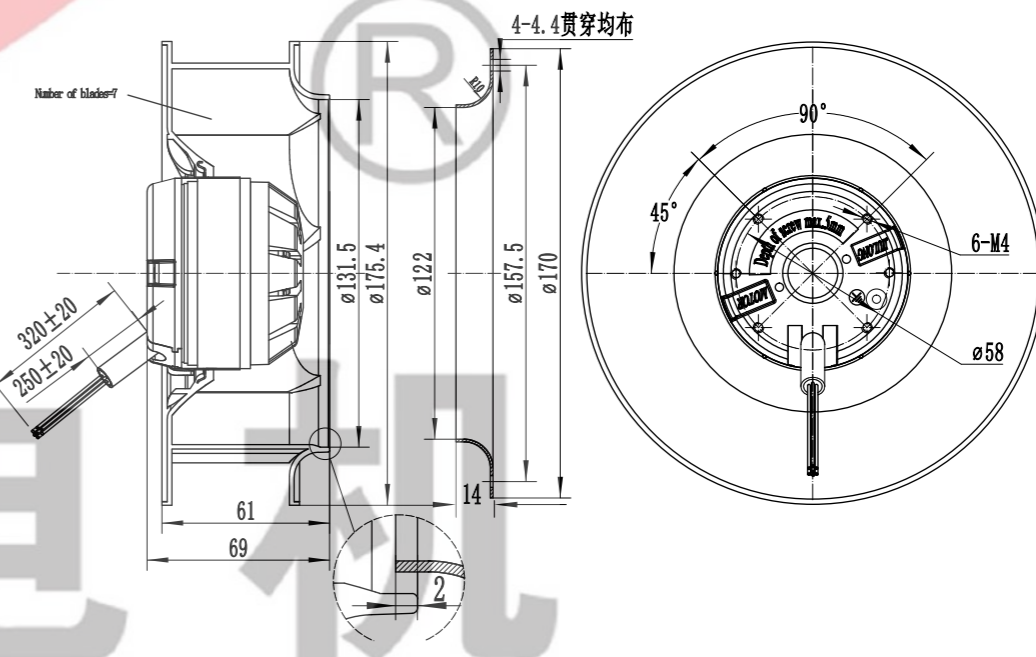

九 龙 电 机





JULONG MOTOR  
AC/DC FANS COOLING FANS

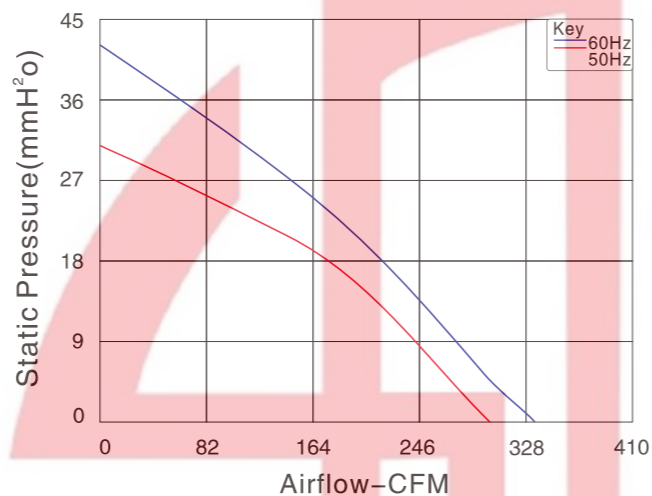

尺寸 Size: Ø190mm × 61mm  
重量 Weight: 1200g  
风叶 Impeller Material: Metal  
马达 Motor: Capacitor-Run And External Rotor Induction Motor  
引线 Lead Wire: Teflon 22# UL 1332(Optional)  
温度范围 Operating Temperature: -10°C~+65°C  
防护等级 Type of protection: IP44  
绝缘等级 Insulation class: "F"

产品型号 Model	电压 Voltage VAC	频率 Freq. Hz	电流 Current A	功率 Power W	转速 Speed RPM	噪音 Noise dB(A)	电容 Capacitor µF/VAC	风量 Air Flow CFM
JH190A2E01	115	50/60	0.57/0.75	62/78	2600/2950	64/69	8/500	302/338
JH190A2E02	230	50/60	0.45/0.49	80/88	2600/2950	64/69	2.2/500	302/338
JH190A2E03	380	50/60	0.38/0.31	122/132	2600/2950	64/69	/	302/338
JH190A2E06	380	50	0.15	60	2600	64	1/500	302

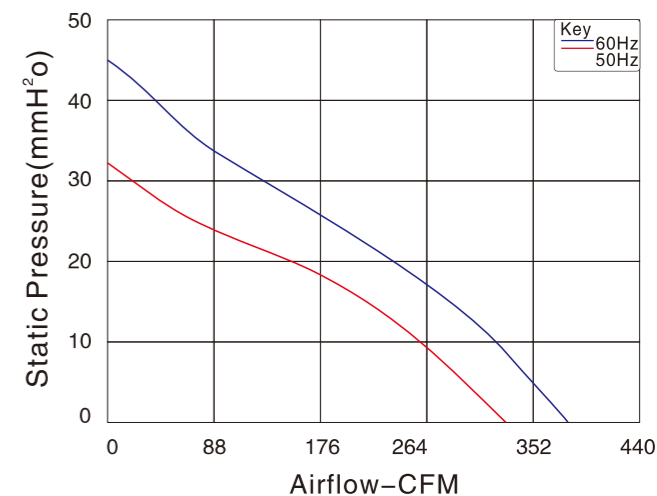
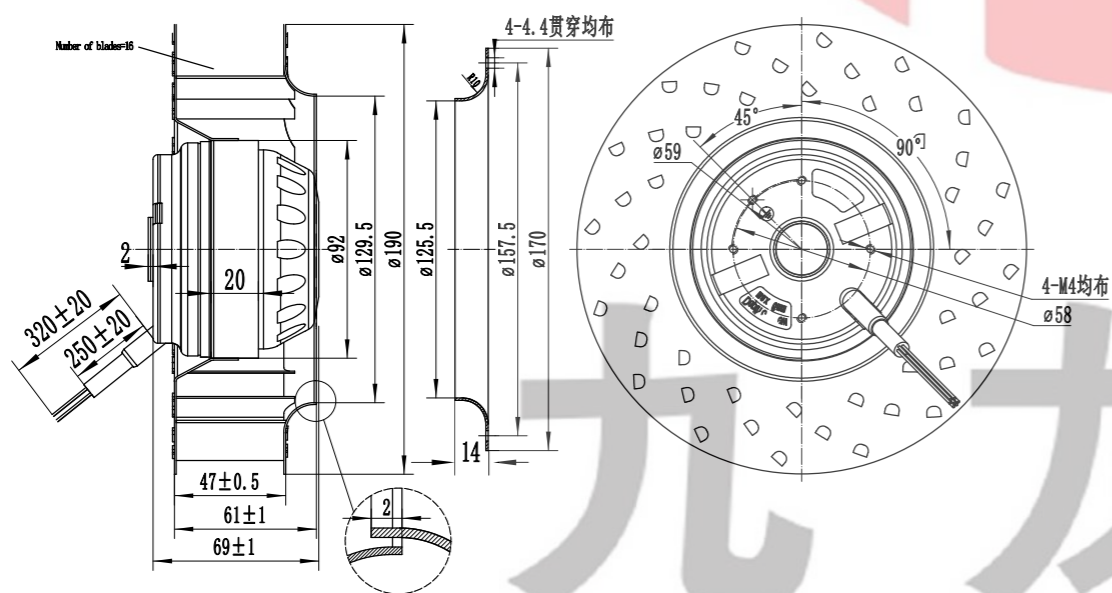

尺寸 Size: Ø190mm × 61mm  
重量 Weight: 1200g  
风叶 Impeller Material: PA66  
马达 Motor: Capacitor-Run And External Rotor Induction Motor  
引线 Lead Wire: Teflon 22# UL 1332(Optional)  
温度范围 Operating Temperature: -10°C~+65°C  
防护等级 Type of protection: IP44  
绝缘等级 Insulation class: "F"

产品型号 Model	电压 Voltage VAC	频率 Freq. Hz	电流 Current A	功率 Power W	转速 Speed RPM	噪音 Noise dB(A)	电容 Capacitor µF/VAC	风量 Air Flow CFM
JH190B2E01	115	50/60	0.6/0.7	62/78	2600/2950	58/68	8/500	336/356
JH190B2E02	230	50/60	0.45/0.49	78/80	2600/2950	58/68	2.2/500	336/356
JH190B2E03	380	50/60	0.38/0.31	122/132	2600/2950	58/68	/	336
JH190B2E06	380	50	0.15	60	2600	58	1/500	336

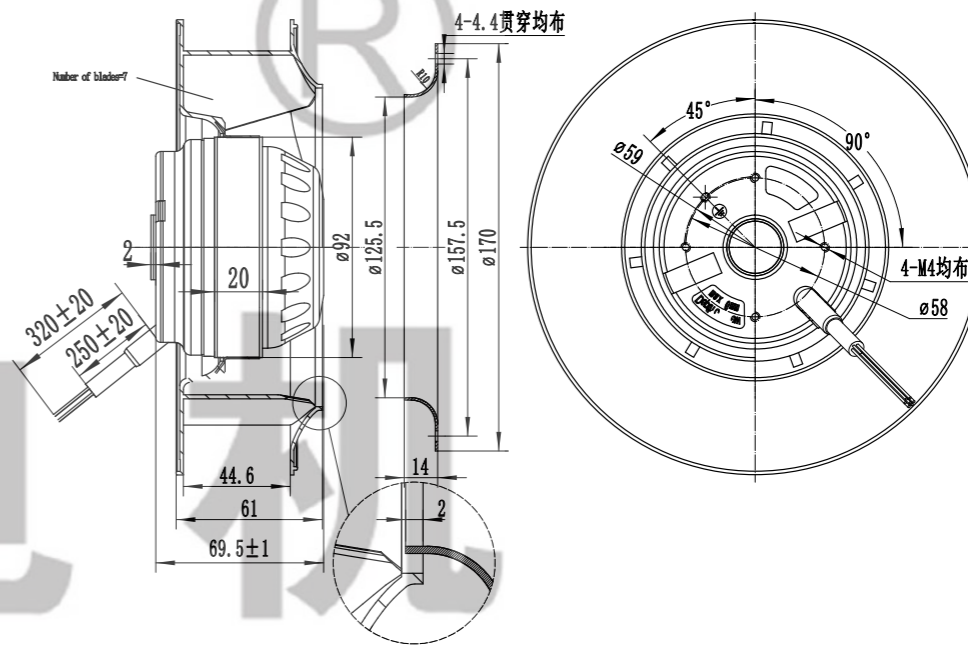



JULONG MOTOR  
AC/DC FANS COOLING FANS



本样图仅供参考，具体以实物为准。  
This sample book is for reference only. Please refer to the specification for details.  
如需特殊电压也可根据需求提供。本公司保留技术知识产权。  
Special voltage may be provided flexibly according to the query. All technical modification rights reserved.

Http://www.xtgygs.cn

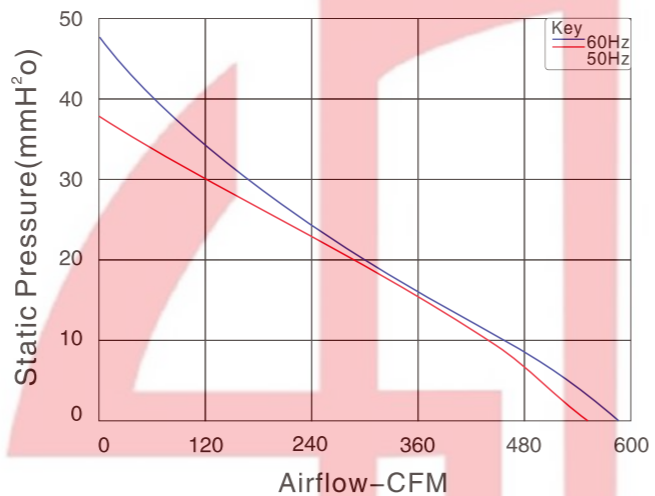

尺寸 Size: Ø220mm × 61mm  
重量 Weight: 1700g  
风叶 Impeller Material: PA66  
马达 Motor: Capacitor-Run And External Rotor Induction Motor  
引线 Lead Wire: Teflon 22# UL 1332(Optional)  
温度范围 Operating Temperature: -10°C~+65°C  
防护等级 Type of protection: IP44  
绝缘等级 Insulation class: "F"

产品型号 Model	电压 Voltage VAC	频率 Freq. Hz	电流 Current A	功率 Power W	转速 Speed RPM	噪音 Noise dB(A)	电容 Capacitor µF/VAC	风量 Air Flow CFM
JH220A2E01	115	50/60	0.74/0.85	80/95	2400/2600	72/75	8/250	524/583
JH220A2E02	230	50/60	0.45/0.46	80/95	2400/2600	72/75	4/500	524/583

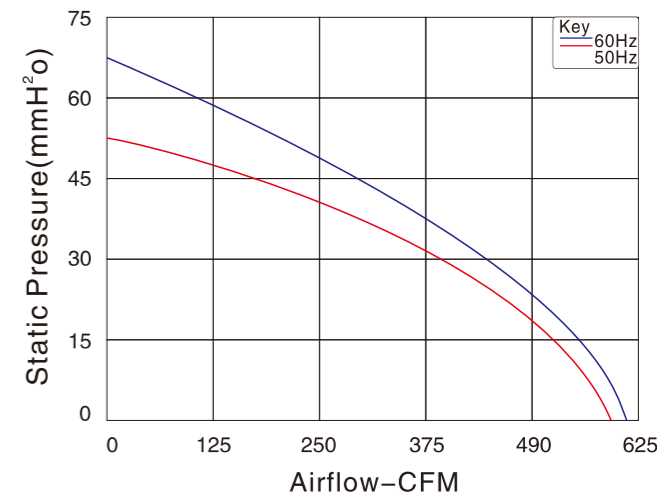
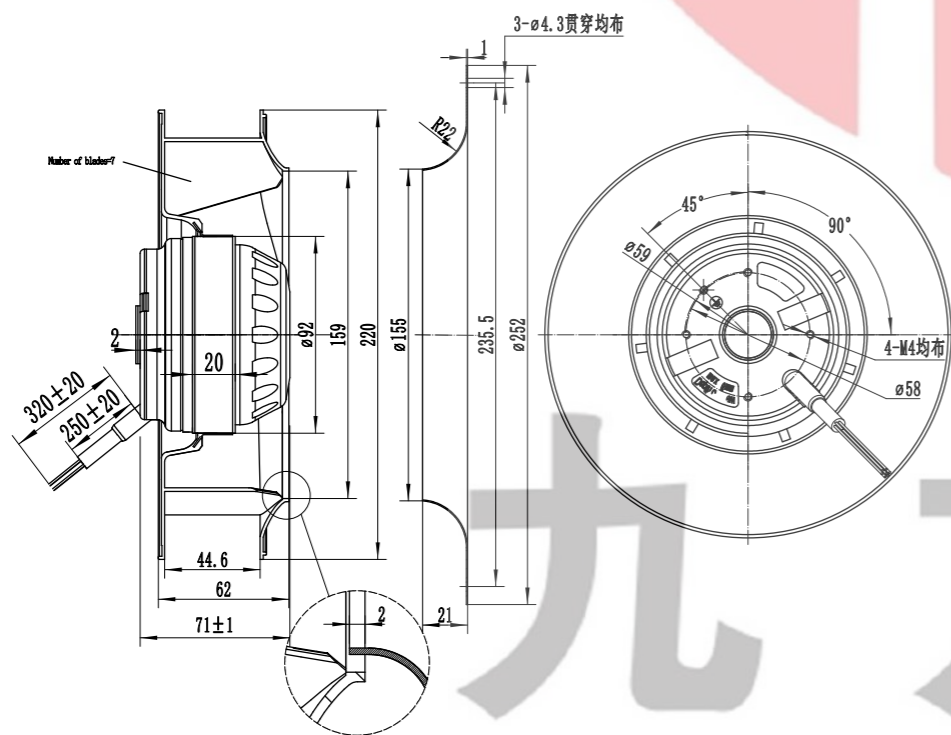

尺寸 Size: Ø225mm × 75mm  
重量 Weight: 2700g  
风叶 Impeller Material: Metal  
马达 Motor: Capacitor-Run And External Rotor Induction Motor  
引线 Lead Wire: Teflon 22# UL 1332(Optional)  
温度范围 Operating Temperature: -10°C~+65°C  
防护等级 Type of protection: IP44  
绝缘等级 Insulation class: "F"

产品型号 Model	电压 Voltage VAC	频率 Freq. Hz	电流 Current A	功率 Power W	转速 Speed RPM	噪音 Noise dB(A)	电容 Capacitor µF/VAC	风量 Air Flow CFM
JH225A2E02	230	50/60	0.57/0.8	100/135	2550/2750	72/75	4/500	592/603
JH225A2E03	380	50/60	0.32/0.33	145/180	2550/2750	72/75	/	592/603

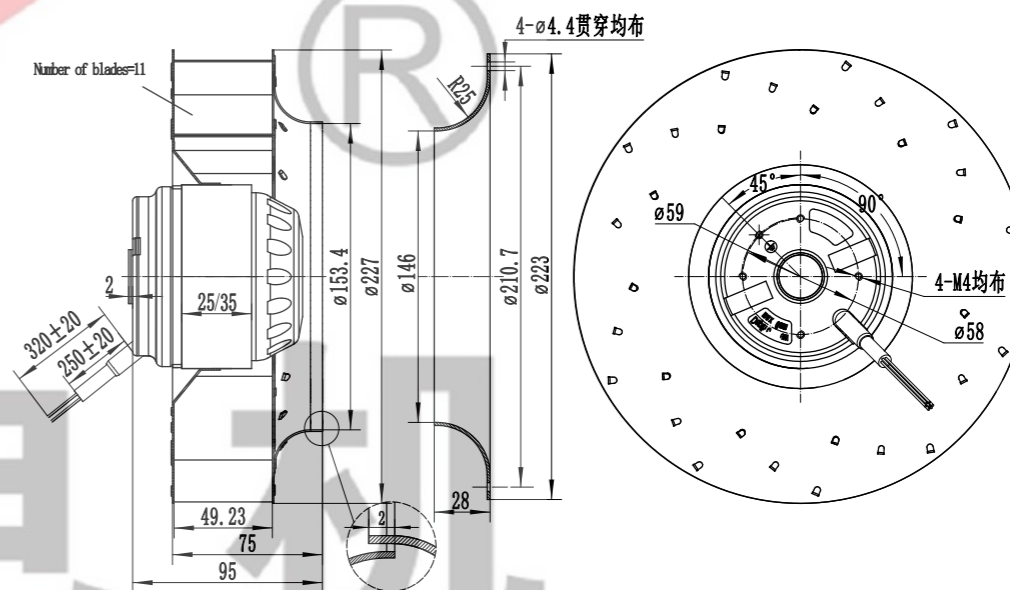

九 龙 电 机

AC Axial Fan  
AC轴流风机

AC All-Metal Axial Fan  
AC全金属轴流风扇

DC Axial Fan  
DC轴流风机

DC Centrifugal Fan  
DC离心风机

EC Axial Fan  
EC轴流风机

EC Centrifugal Fan  
EC离心风机

AC Centrifugal Fan  
AC离心风机

Fan Accessories  
风机配件



JIULONG MOTOR  
AC/DC FANS COOLING FANS

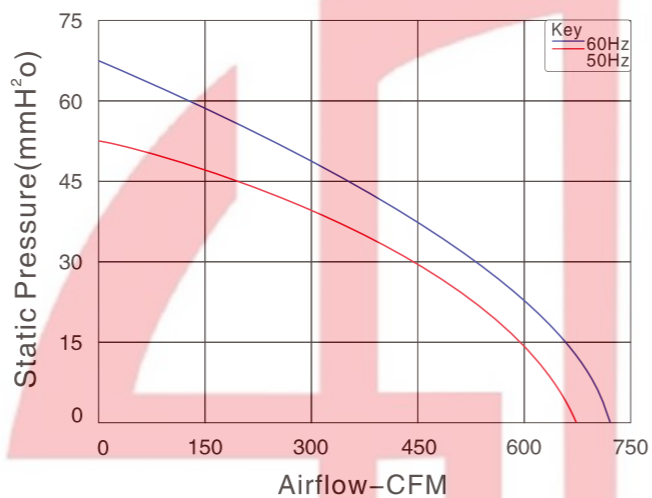

尺寸 Size: Ø225mm × 75mm  
重量 Weight: 2700g  
风叶 Impeller Material: PA66  
马达 Motor: Capacitor-Run And External Rotor Induction Motor  
引线 Lead Wire: Teflon 22# UL 1332(Optional)  
温度范围 Operating Temperature: -10°C~+65°C  
防护等级 Type of protection: IP44  
绝缘等级 Insulation class: "F"

产品型号 Model	电压 Voltage VAC	频率 Freq. Hz	电流 Current A	功率 Power W	转速 Speed RPM	噪音 Noise dB(A)	电容 Capacitor μF/VAC	风量 Air Flow CFM
JH225B2E02	230	50/60	0.57/0.8	100/135	2550/2750	72/75	4/500	618/683
JH225B2E03	380	50/60	0.32/0.33	145/180	2550/2750	72/75	/	618/683

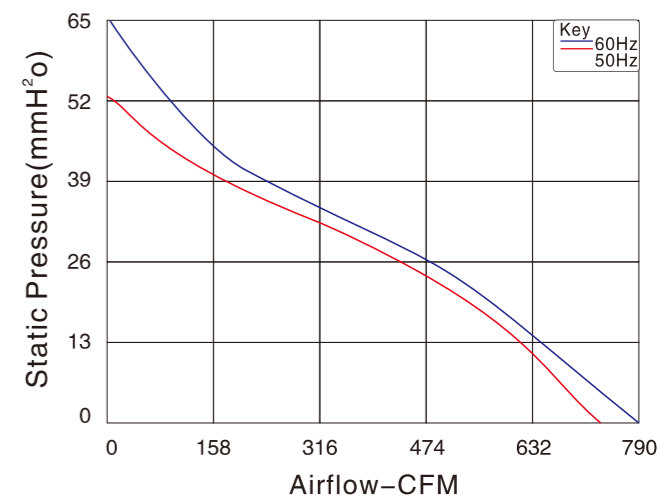
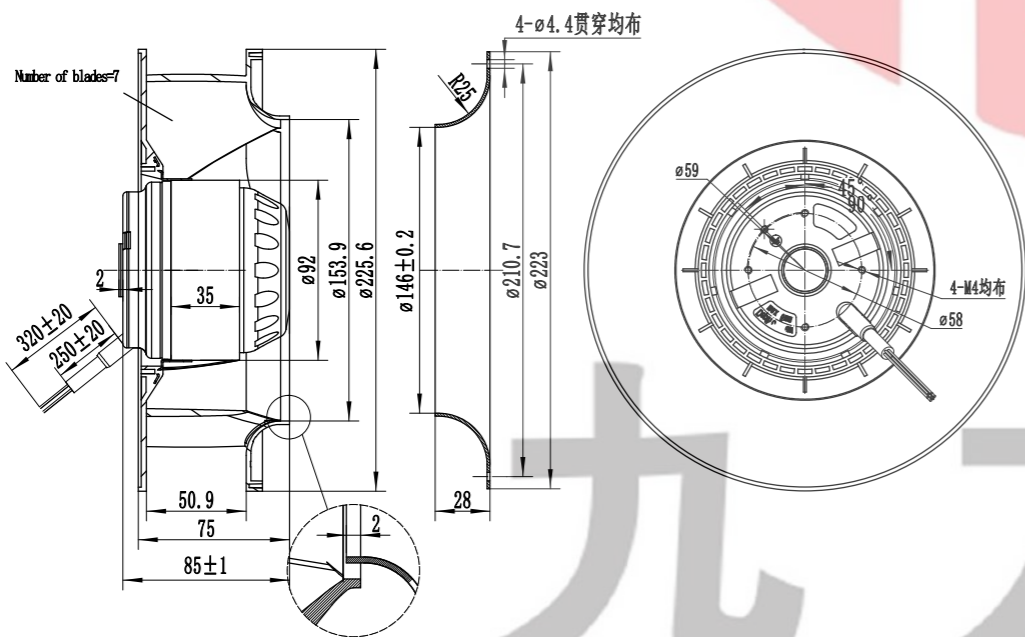

尺寸 Size: Ø225mm × 89mm  
重量 Weight: 2350g  
风叶 Impeller Material: PA66  
马达 Motor: Capacitor-Run And External Rotor Induction Motor  
引线 Lead Wire: Teflon 22# UL 1332(Optional)  
温度范围 Operating Temperature: -10°C~+65°C  
防护等级 Type of protection: IP44  
绝缘等级 Insulation class: "F"

产品型号 Model	电压 Voltage VAC	频率 Freq. Hz	电流 Current A	功率 Power W	转速 Speed RPM	噪音 Noise dB(A)	电容 Capacitor μF/VAC	风量 Air Flow CFM
JH225C2E01	115	50/60	1.3/1.7	150/195	2600/2900	69/71	20/250	706/789
JH225C2E02	230	50/60	0.62/0.83	135/180	2600/2900	69/71	4/500	706/789

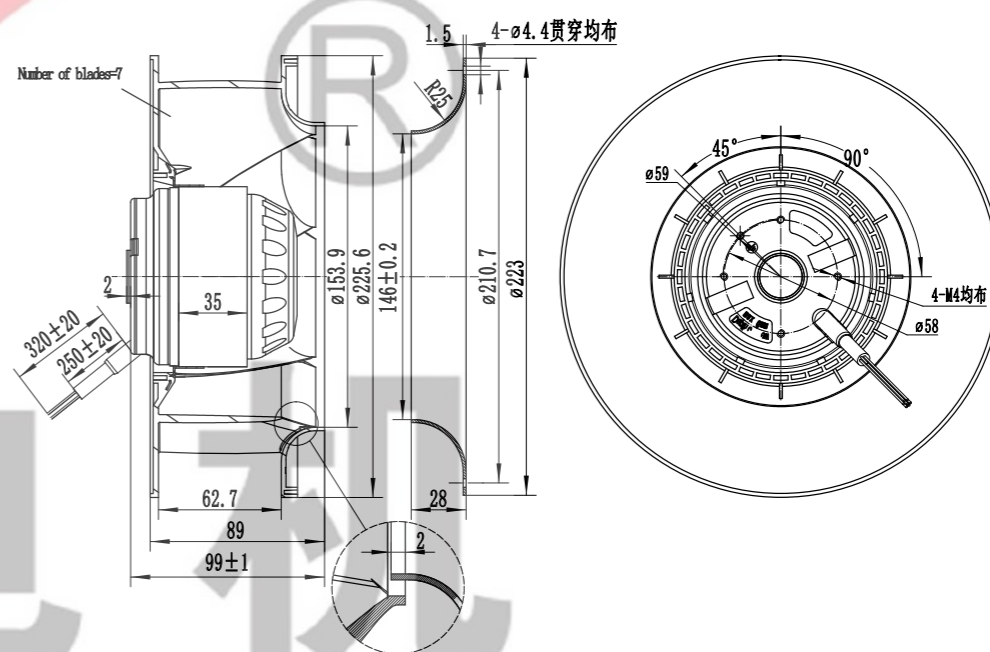

Http://www.xtgygs.cn



JULONG MOTOR  
AC/DC-FANS COOLING FANS



本样机仅做选型参考，具体以规格书为准。  
This sample book is for reference only. Please refer to the specification for details.  
如需特殊电压也可根据需求提供，本公司保留技术更改权利。  
Special voltage may be provided according to the enquiry, although technical modification is reserved.

Http://www.xtgygs.cn

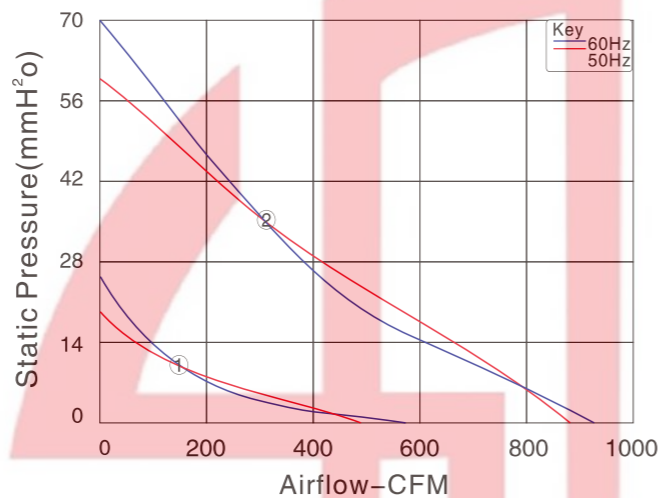

尺寸 Size: Ø250mm × 81mm  
重量 Weight: 2700g  
风叶 Impeller Material: Metal  
马达 Motor: Capacitor-Run And External Rotor Induction Motor  
引线 Lead Wire: Teflon 22# UL 1332(Optional)  
温度范围 Operating Temperature: -10°C~+65°C  
防护等级 Type of protection: IP44  
绝缘等级 Insulation class: "F"

产品型号 Model	电压 Voltage VAC	频率 Freq. Hz	电流 Current A	功率 Power W	转速 Speed RPM	噪音 Noise dB(A)	电容 Capacitor μF/VAC	风量 Air Flow CFM
JH250A2E01 ②	115	50/60	1.3/1.8	152/207	2600/2900	75/78	20/450	854/878
JH250A2E02 ②	230	50/60	0.65/0.85	152/210	2600/2900	75/78	4/500	854/878
JH250A2E03 ②	380	50/60	0.6/0.65	240/280	2600/2900	75/78	/	854/878
JH250A4E02 ①	230	50/60	0.31/0.29	68/63	1450/1650	61/64	4/500	477/548

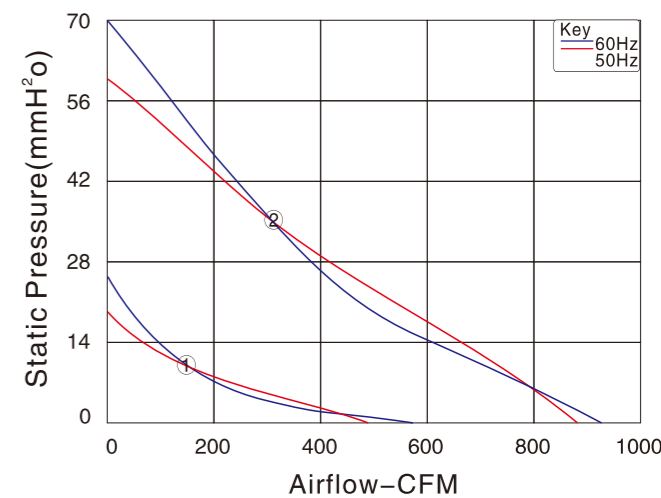

尺寸 Size: Ø250mm × 86mm  
重量 Weight: 2700g  
风叶 Impeller Material: PA66+Metal  
马达 Motor: Capacitor-Run And External Rotor Induction Motor  
引线 Lead Wire: Teflon 22# UL 1332(Optional)  
温度范围 Operating Temperature: -10°C~+65°C  
防护等级 Type of protection: IP44  
绝缘等级 Insulation class: "F"

产品型号 Model	电压 Voltage VAC	频率 Freq. Hz	电流 Current A	功率 Power W	转速 Speed RPM	噪音 Noise dB(A)	电容 Capacitor μF/VAC	风量 Air Flow CFM
JH250B2E01 ②	115	50/60	1.3/1.8	152/207	2600/2900	74/76	20/450	854/878
JH250B2E02 ②	230	50/60	0.65/0.85	152/210	2600/2900	74/76	4/500	854/878
JH250B2E03 ②	380	50/60	0.6/0.65	240/280	2600/2900	74/76	/	854/878
JH250B4E02 ①	230	50/60	0.31/0.29	68/63	1450/1650	61/64	4/500	385/438

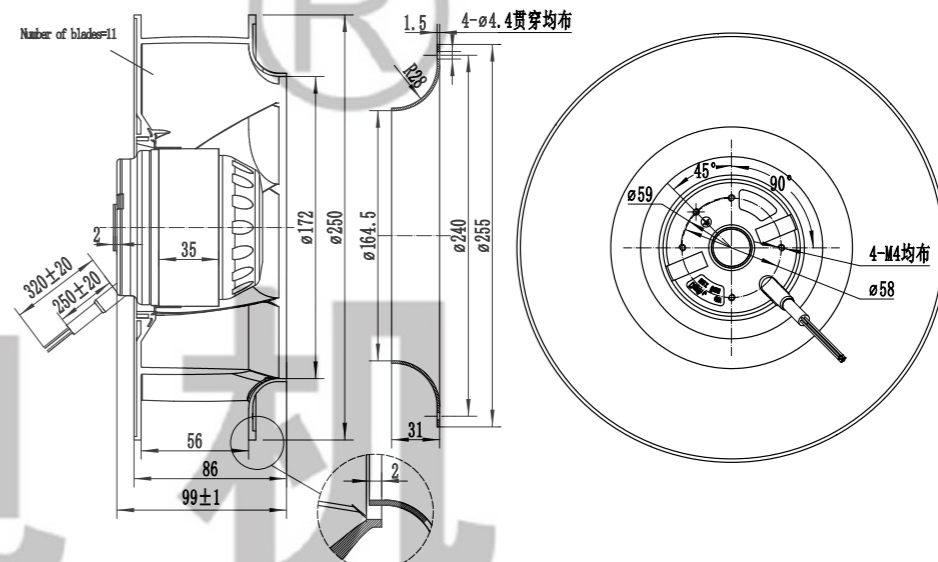
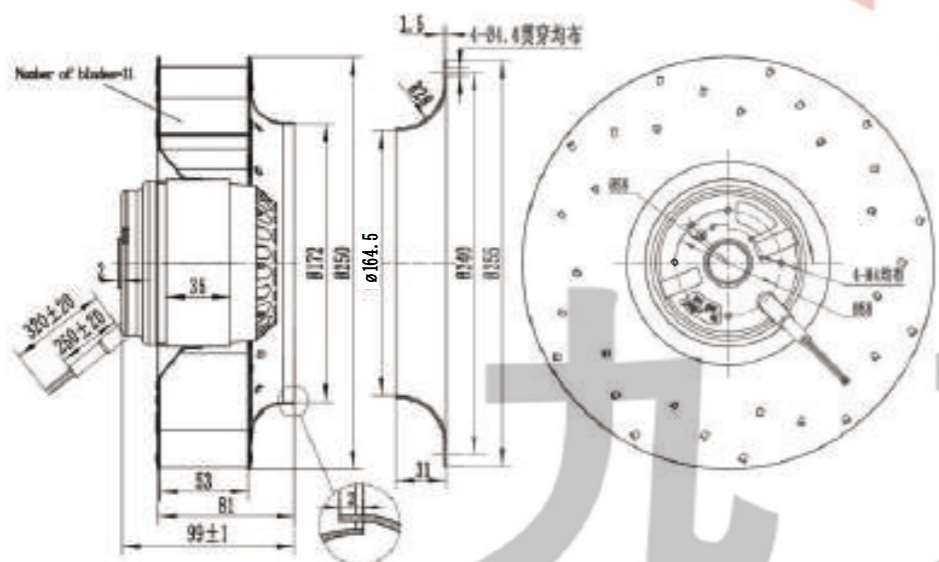

九 龙 电 视

AC Axial Fan  
AC轴流风机

AC All-Metal Axial Fan  
AC全金属轴流风扇

DC Axial Fan  
DC轴流风机

DC Centrifugal Fan  
DC离心风机

EC Axial Fan  
EC轴流风机

EC Centrifugal Fan  
EC离心风机

AC Centrifugal Fan  
AC离心风机

Fan Accessories  
风机配件



JULONG MOTOR  
AC/DC FANS COOLING FANS



本样机仅做选型参考，具体以规格书为准。  
This sample book is for reference only. Please refer to the specification for details.  
如需特殊电压也可根据需求提供。本公司保留技术知识产权。  
Special voltage may be provided flexibly according to the enquiry. All technical modification rights reserved.

Http://www.xtgygs.cn

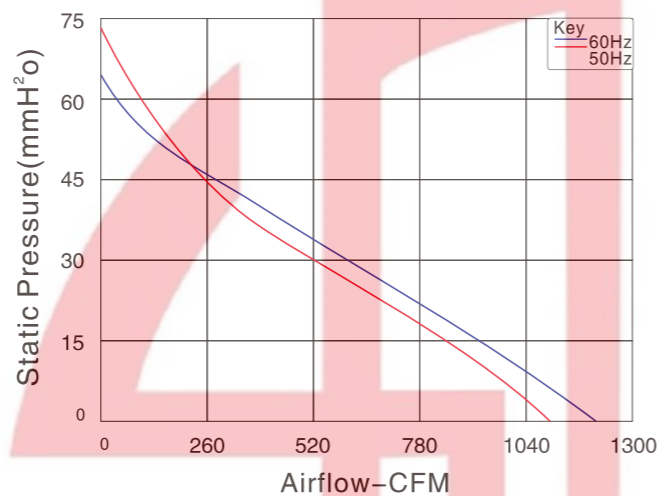

尺寸 Size: Ø280mm × 81mm  
重量 Weight: 2805g  
风叶 Impeller Material: Metal  
马达 Motor: Capacitor-Run And External Rotor Induction Motor  
引线 Lead Wire: Teflon 22# UL 1332(Optional)  
温度范围 Operating Temperature: -10°C~+65°C  
防护等级 Type of protection: IP44  
绝缘等级 Insulation class: "F"

产品型号 Model	电压 Voltage VAC	频率 Freq. Hz	电流 Current A	功率 Power W	转速 Speed RPM	噪音 Noise dB(A)	电容 Capacitor μF/VAC	风量 Air Flow CFM
JH280A2E01	115	50/60	2/2.8	240/320	2550/2650	73/77	20/450	1148/1237
JH280A2E02	230	50/60	0.95/1.3	200/270	2550/2650	73	8/450	1148
JH280A2E03	380	50	0.39	230	2550/2650	73	/	1148

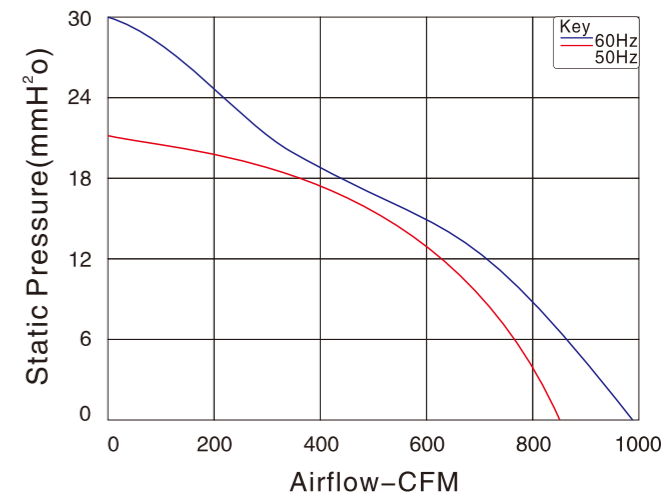
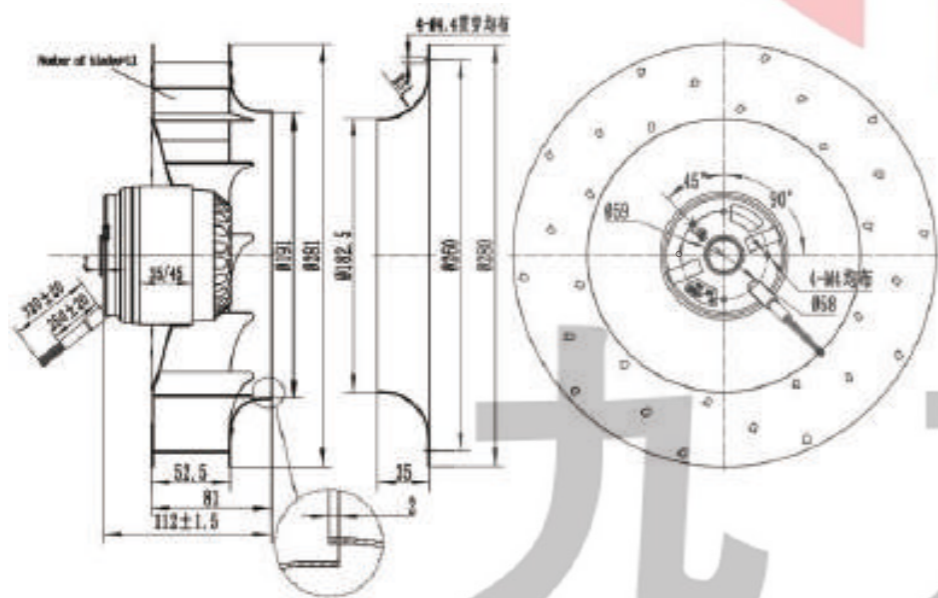

尺寸 Size: Ø280mm × 112mm  
重量 Weight: 3100g  
风叶 Impeller Material: Metal  
马达 Motor: Capacitor-Run And External Rotor Induction Motor  
引线 Lead Wire: Teflon 22# UL 1332(Optional)  
温度范围 Operating Temperature: -10°C~+65°C  
防护等级 Type of protection: IP44  
绝缘等级 Insulation class: "F"

产品型号 Model	电压 Voltage VAC	频率 Freq. Hz	电流 Current A	功率 Power W	转速 Speed RPM	噪音 Noise dB(A)	电容 Capacitor μF/VAC	风量 Air Flow CFM
JH280B4E01	115	50/60	0.6/0.8	53/72	1400/1650	61/66	8/450	845/992
JH280B4E02	230	50/60	0.26/0.35	50/68	1400/1650	61/66	4/500	845/992

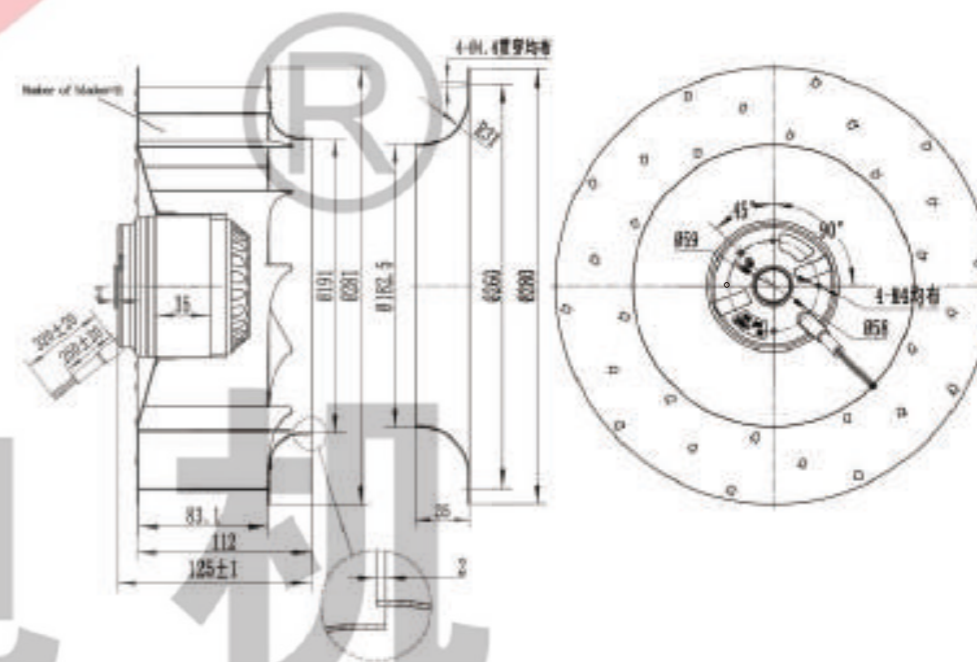

九 龙 电 机



JULONG MOTOR  
AC/DC FANS COOLING FANS



本样图仅供参考，具体以实物为准。  
This sample book is for reference only, please refer to the specification for details.  
如需特殊电压也可根据需求提供，本公司保留技术更改权利。  
Special voltage may be provided according to the requirement, although technical modification rights reserved.

Http://www.xtgygs.cn

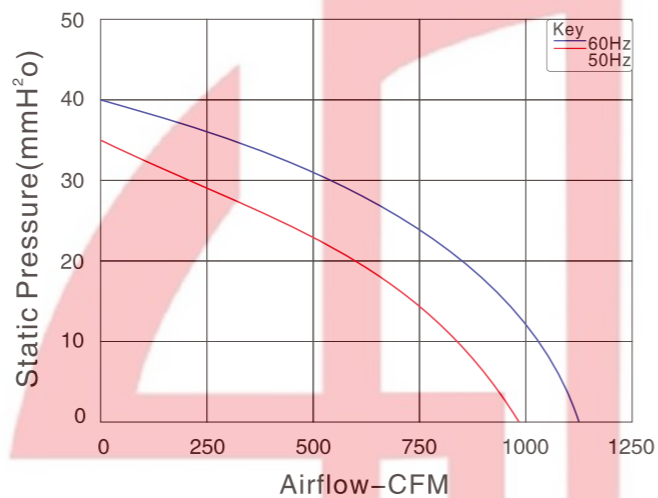

尺寸 Size: Ø320mm × 108mm  
重量 Weight: 3600g  
风叶 Impeller Material: Aluminium  
马达 Motor: Capacitor-Run And External Rotor Induction Motor  
引线 Lead Wire: Teflon 18# UL 1332(Optional)  
温度范围 Operating Temperature: -10°C~+65°C  
防护等级 Type of protection: IP44  
绝缘等级 Insulation class: "F"

产品型号 Model	电压 Voltage VAC	频率 Freq. Hz	电流 Current A	功率 Power W	转速 Speed RPM	噪音 Noise dB(A)	电容 Capacitor μF/VAC	风量 Air Flow CFM
JH320A4E02	230	50/60	0.42/0.69	100/120	1400/1600	62/66	5/500	1007/1177
JH320A4E03	380	50/60	0.23/0.34	100/120	1400/1600	62/66	/	1007/1177

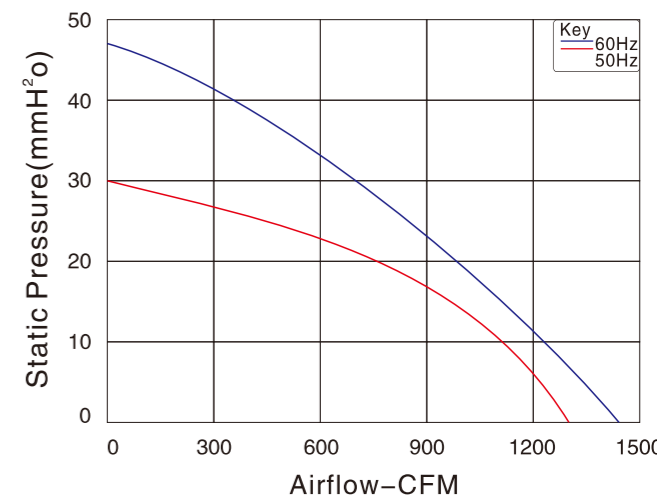
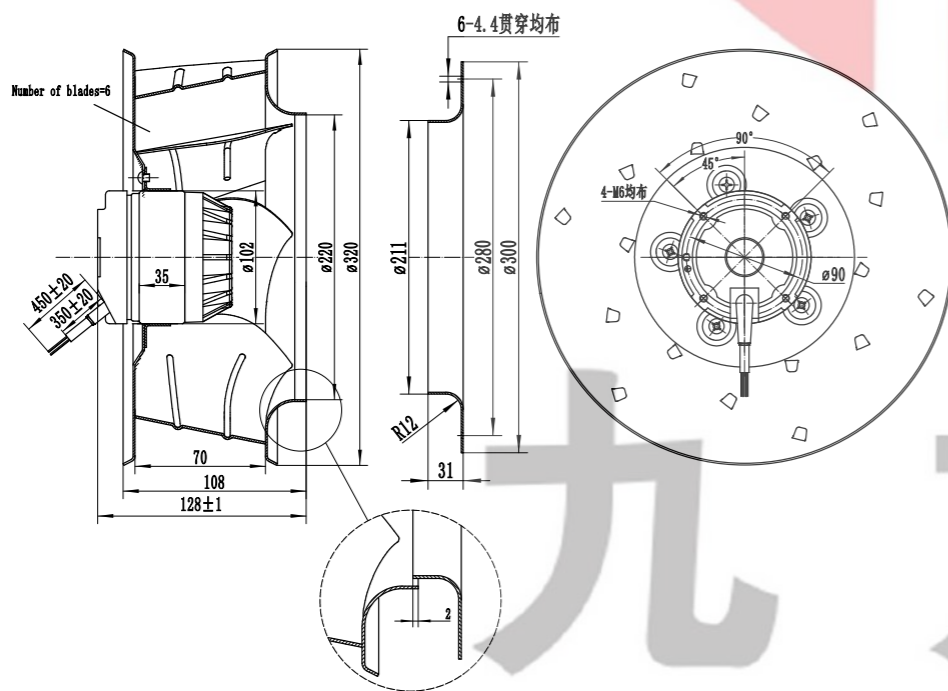

尺寸 Size: Ø320mm × 140mm  
重量 Weight: 3850g  
风叶 Impeller Material: Aluminium  
马达 Motor: Capacitor-Run And External Rotor Induction Motor  
引线 Lead Wire: Teflon 18# UL 1332(Optional)  
温度范围 Operating Temperature: -10°C~+65°C  
防护等级 Type of protection: IP44  
绝缘等级 Insulation class: "F"

产品型号 Model	电压 Voltage VAC	频率 Freq. Hz	电流 Current A	功率 Power W	转速 Speed RPM	噪音 Noise dB(A)	电容 Capacitor μF/VAC	风量 Air Flow CFM
JH320B4E01	115	50/60	1.2/1.5	134/162	1350/1550	63/66	25/450	1248/1442
JH320B4E02	230	50/60	0.6/0.8	135/185	1350/1550	63/66	5/500	1248/1442
JH320B4E03	380	50/60	0.55/0.65	230/270	1350/1550	63/66	/	1248/1442

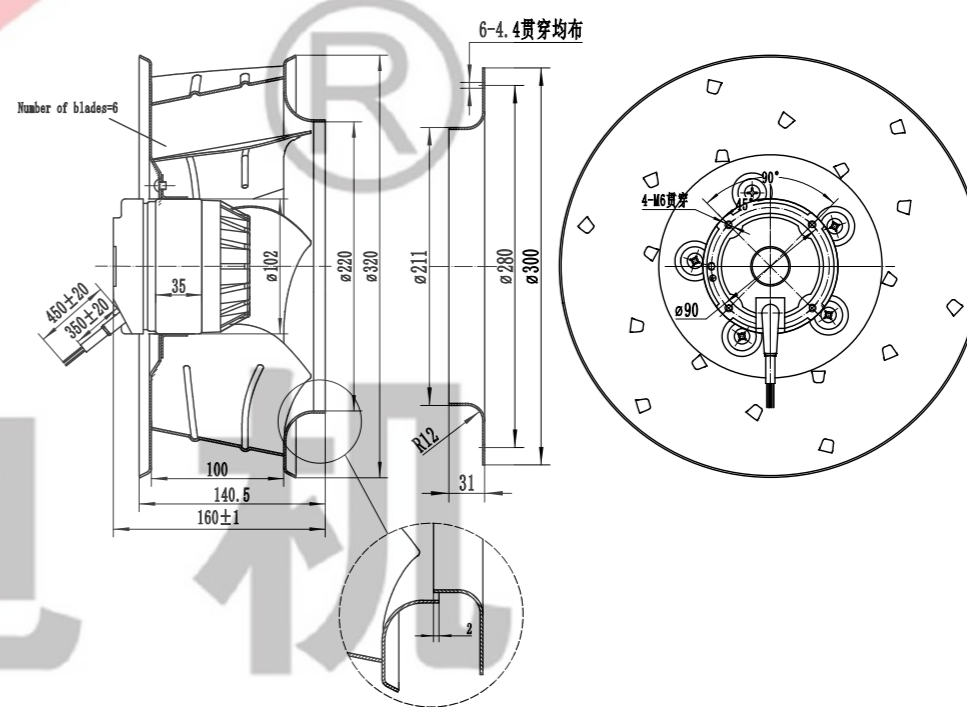

AC Axial Fan  
AC轴流风机

AC All-Metal Axial Fan  
AC全金属轴流风扇

DC Axial Fan  
DC轴流风机

DC Centrifugal Fan  
DC离心风机

EC Axial Fan  
EC轴流风机

EC Centrifugal Fan  
EC离心风机

AC Centrifugal Fan  
AC离心风机

Fan Accessories  
风机配件



JULONG MOTOR  
AC/DC FANS COOLING FANS



本样图仅供参考，具体以实物为准。  
This sample book is for reference only. Please refer to the specification for details.  
如需特殊电压也可根据需求提供。本公司保留技术知识产权。  
Special voltage may be provided flexibly according to the query. All rights reserved.

Http://www.xtgygs.cn

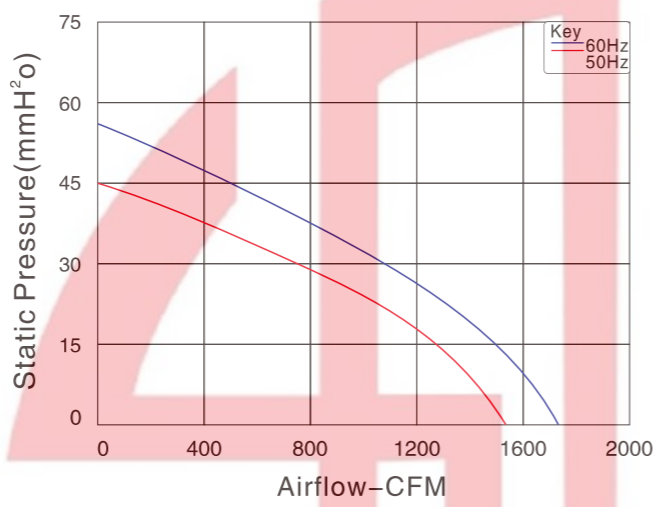

尺寸 Size: Ø355mm × 147mm  
重量 Weight: 4700g  
风叶 Impeller Material: Aluminium  
马达 Motor: Capacitor-Run And External Rotor Induction Motor  
引线 Lead Wire: Teflon 18# UL 1332(Optional)  
温度范围 Operating Temperature: -10°C~+65°C  
防护等级 Type of protection: IP44  
绝缘等级 Insulation class: "F"

产品型号 Model	电压 Voltage VAC	频率 Freq. Hz	电流 Current A	功率 Power W	转速 Speed RPM	噪音 Noise dB(A)	电容 Capacitor μF/VAC	风量 Air Flow CFM
JH355A4E01	115	50/60	2/2.3	185/240	1350/1550	66/69	8/500	1519/1731
JH355A4E02	230	50/60	0.8/0.9	165/200	1350/1550	66/69	8/500	1519/1731
JH355A4E03	380	50/60	0.46/0.48	178/250	1350/1550	66/69	/	1519/1731
JH355A4E06	380	50	0.5/0.6	170/258	1350/1550	66/69	5/500	1519/1731

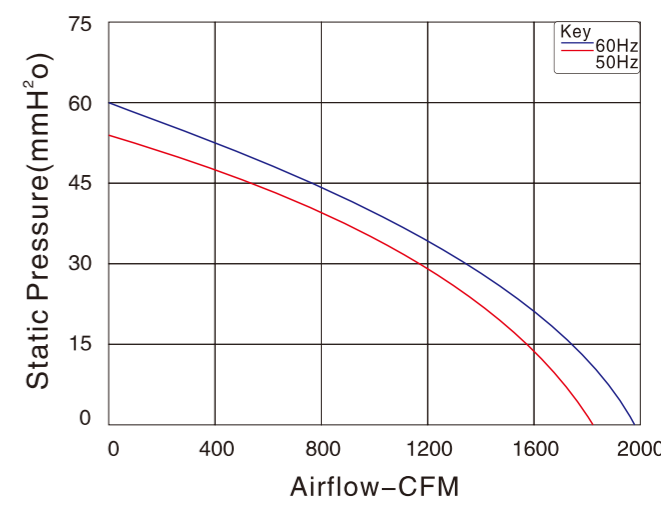
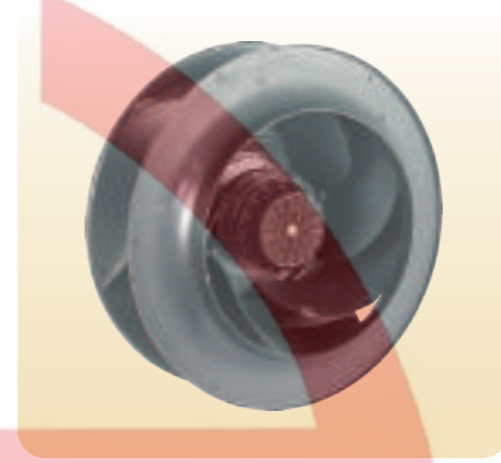
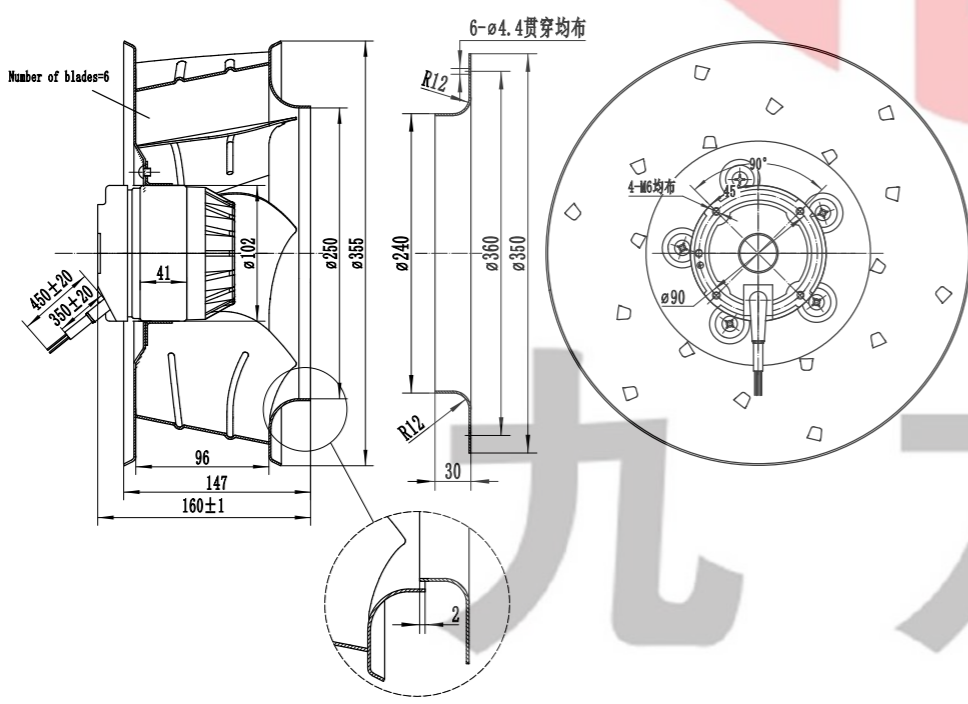

尺寸 Size: Ø400mm × 140mm  
重量 Weight: 5650g  
风叶 Impeller Material: Aluminium  
马达 Motor: Capacitor-Run And External Rotor Induction Motor  
引线 Lead Wire: Teflon 18# UL 1332(Optional)  
温度范围 Operating Temperature: -10°C~+65°C  
防护等级 Type of protection: IP44  
绝缘等级 Insulation class: "F"

产品型号 Model	电压 Voltage VAC	频率 Freq. Hz	电流 Current A	功率 Power W	转速 Speed RPM	噪音 Noise dB(A)	电容 Capacitor μF/VAC	风量 Air Flow CFM
JH400A4E02	230	50/60	1.2/1.5	260/330	1300/1450	68/70	8/450	1855/1943
JH400A4E03	380	50	0.6	265	1300	68	/	1855

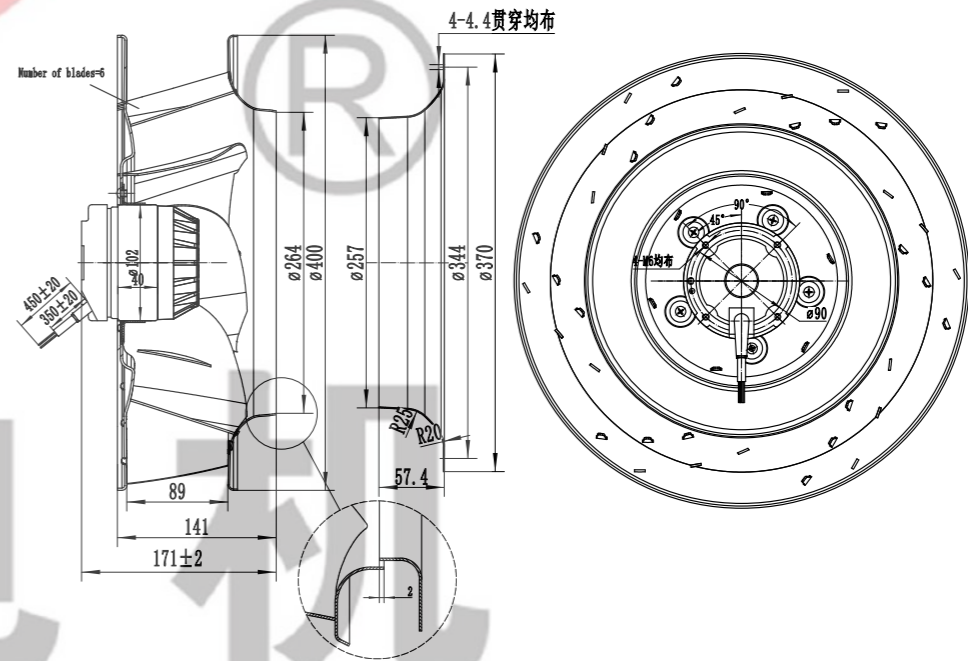

九 龙 电 机

AC Axial Fan  
AC轴流风机

AC All-Metal Axial Fan  
AC全金属轴流风扇

DC Axial Fan  
DC轴流风机

DC Centrifugal Fan  
DC离心风机

EC Axial Fan  
EC轴流风机

EC Centrifugal Fan  
EC离心风机

AC Centrifugal Fan  
AC离心风机

Fan Accessories  
风机配件



JULONG MOTOR  
AC/DC FANS COOLING FANS



UL  
E248719



本样图仅供参考，具体以实物为准。  
This sample book is for reference only. Please refer to the specification for details.  
如需特殊电压也可根据需求提供，本公司保留技术知识产权。  
Special voltage may be provided according to the requirement, although technical modification is reserved.

Http://www.xtgygs.cn

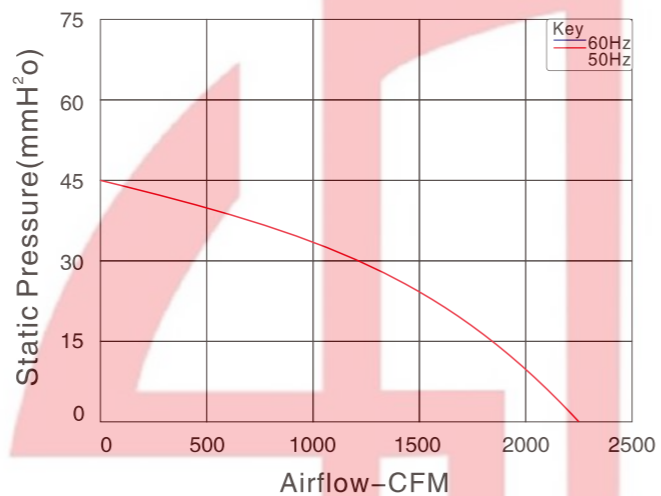

尺寸 Size: Ø400mm × 188mm  
重量 Weight: 100000g  
风叶 Impeller Material: Aluminium  
马达 Motor: Capacitor-Run And External Rotor Induction Motor  
引线 Lead Wire: Teflon 18# UL 1332(Optional)  
温度范围 Operating Temperature: -10°C~+65°C  
防护等级 Type of protection: IP44  
绝缘等级 Insulation class: "F"

产品型号 Model	电压 Voltage VAC	频率 Freq. Hz	电流 Current A	功率 Power W	转速 Speed RPM	噪音 Noise dB(A)	电容 Capacitor µF/VAC	风量 Air Flow CFM
JH400B4E02	230	50	1.2	275	1350	68	8/500	2355
JH400B4E03	380	50	0.65	300	1350	68	/	2355

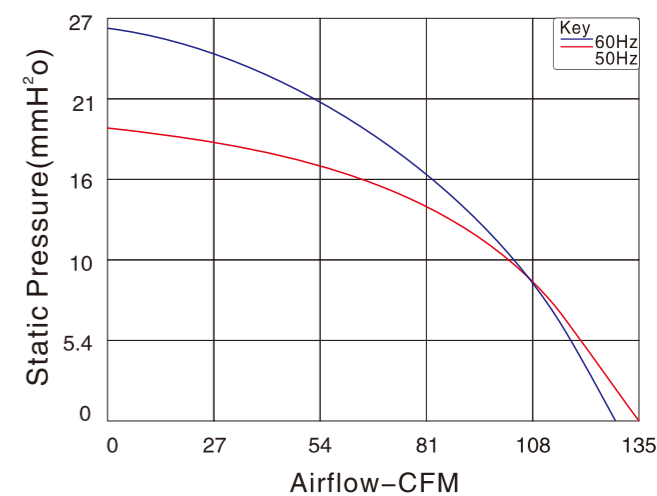
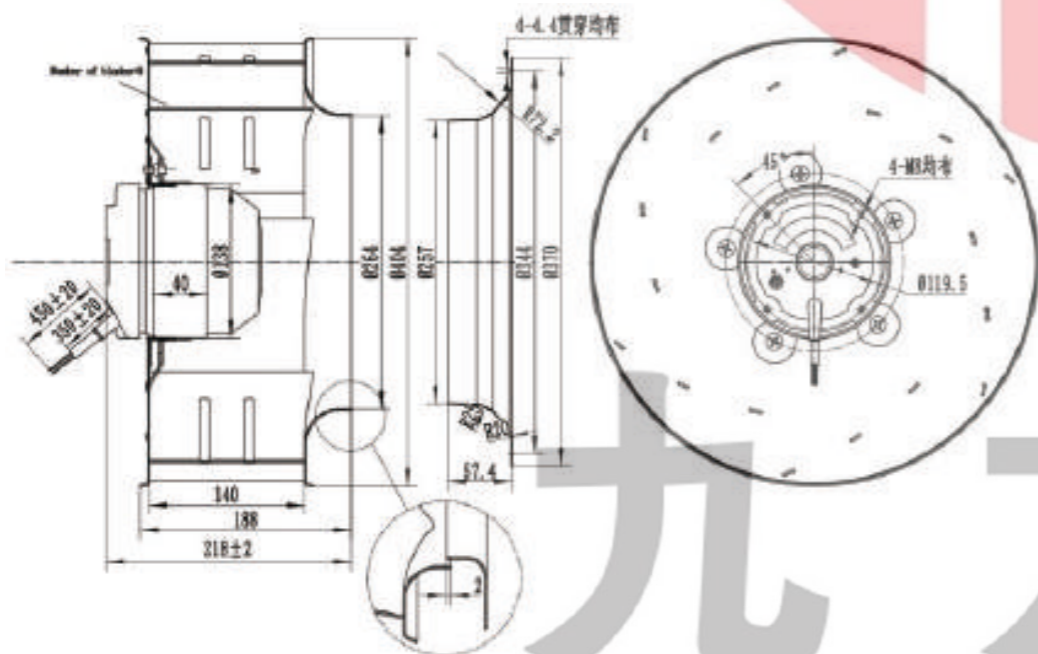

尺寸 Size: Ø97mm × 85mm  
重量 Weight: 1500g  
风叶 Impeller Material: SGCC  
马达 Motor: Capacitor-Run And External Rotor Induction Motor  
引线 Lead Wire: AWG#UL1332 22#(Optional)  
温度范围 Operating Temperature: -10°C~+65°C  
防护等级 Type of protection: IP42  
绝缘等级 Insulation class: "F"

产品型号 Model	电压 Voltage VAC	频率 Freq. Hz	电流 Current A	功率 Power W	转速 Speed RPM	噪音 Noise dB(A)	电容 Capacitor µF/VAC	风量 Air Flow CFM
JS097A2E02-W	230	50/60	0.16/0.19	33/40	1800/1750	54/53	1.5/500	134/128

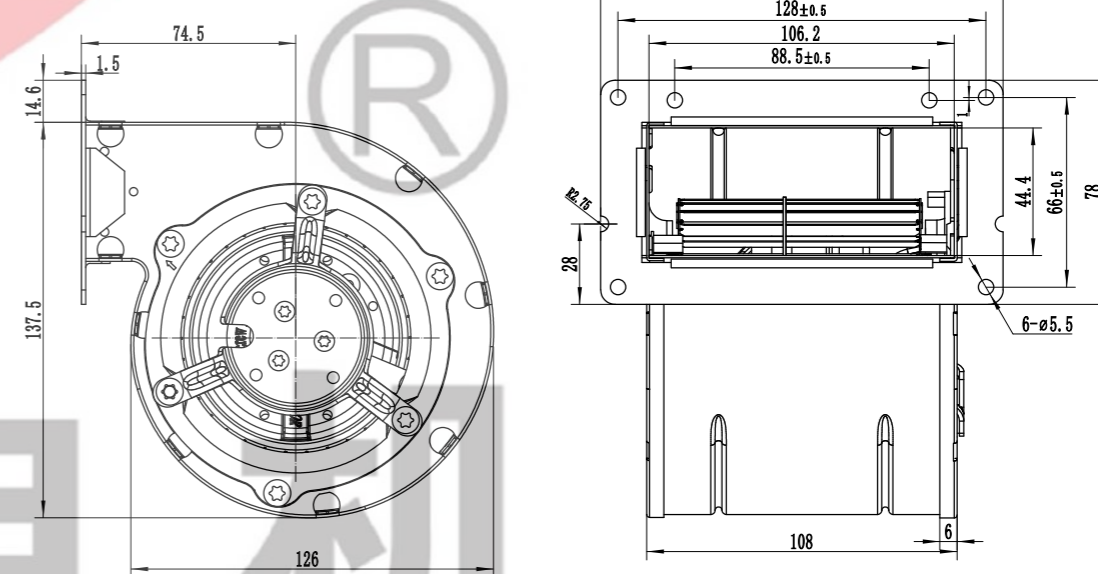

九 龙 电 机

AC Axial Fan  
AC轴流风机

AC All-Metal Axial Fan  
AC全金属轴流风扇

DC Axial Fan  
DC轴流风机

DC Centrifugal Fan  
DC离心风机

EC Axial Fan  
EC轴流风机

EC Centrifugal Fan  
EC离心风机

AC Centrifugal Fan  
AC离心风机

Fan Accessories  
风机配件



JULONG MOTOR  
AC/DC FANS COOLING FANS



本样图仅供参考，具体以实物为准。  
This sample book is for reference only. Please refer to the specification for details.  
如需特殊电压也可单独定制提供。本公司保留技术知识产权。  
Special voltage may be provided flexibly according to the query. All technical modification rights reserved.

Http://www.xtgygs.cn

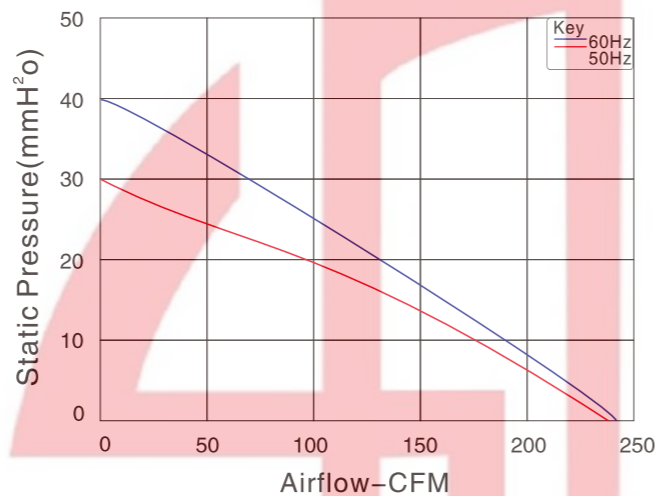

尺寸 Size: Ø120mm × 122mm  
重量 Weight: 3200g  
风叶 Impeller Material: Metal  
马达 Motor: Capacitor-Run And External Rotor Induction Motor  
引线 Lead Wire: Teflon 22# UL 1332(Optional)  
温度范围 Operating Temperature: -10°C~+65°C  
防护等级 Type of protection: IP44  
绝缘等级 Insulation class: "F"

产品型号 Model	电压 Voltage VAC	频率 Freq. Hz	电流 Current A	功率 Power W	转速 Speed RPM	噪音 Noise dB(A)	电容 Capacitor μF/VAC	风量 Air Flow CFM
JS120A2E02-W	230	50/60	0.61/0.73	127/168	2400	66	4/630	230/236

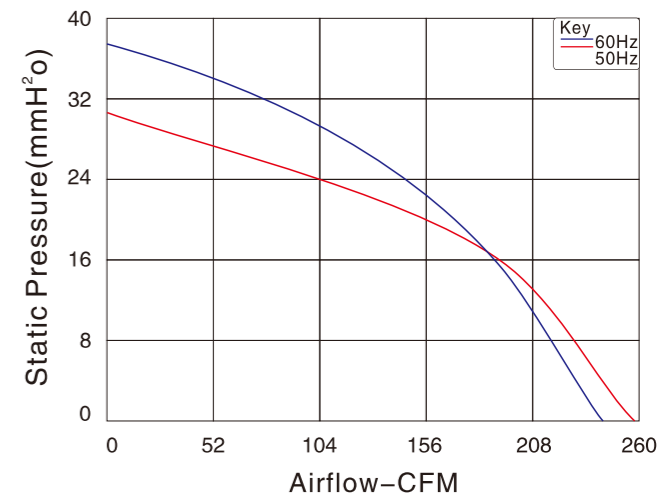
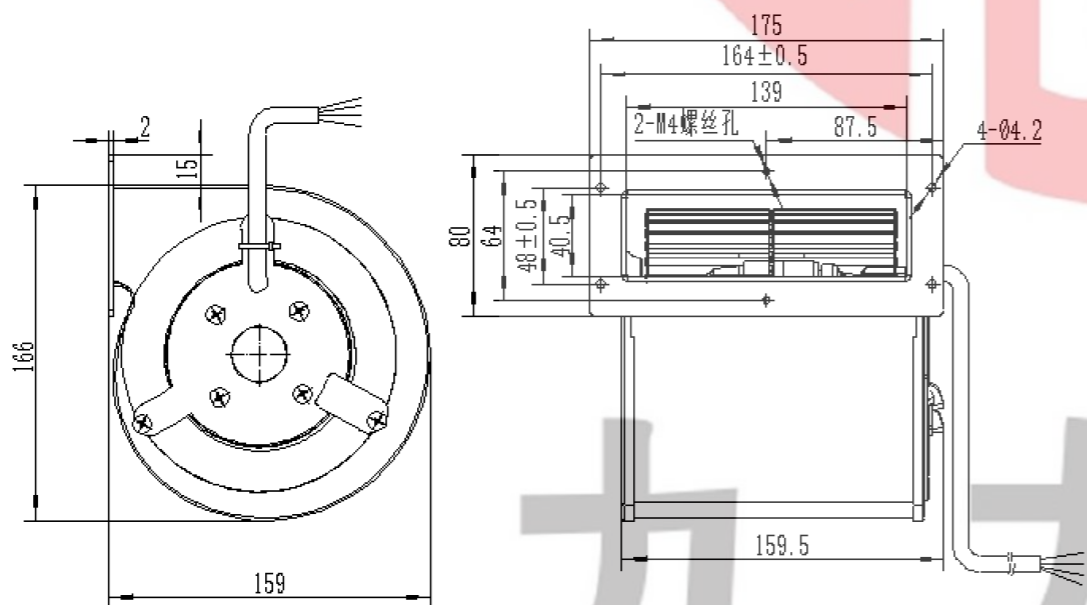

尺寸 Size: Ø120mm × 133mm  
重量 Weight: 3300g  
风叶 Impeller Material: SGCC  
马达 Motor: Capacitor-Run And External Rotor Induction Motor  
引线 Lead Wire: AWG#UL1332 22#(Optional)  
温度范围 Operating Temperature: -10°C~+65°C  
防护等级 Type of protection: IP42  
绝缘等级 Insulation class: "F"

产品型号 Model	电压 Voltage VAC	频率 Freq. Hz	电流 Current A	功率 Power W	转速 Speed RPM	噪音 Noise dB(A)	电容 Capacitor μF/VAC	风量 Air Flow CFM
JS120B2E02-W	230	50/60	0.38/0.42	80/90	1550/1450	53/52	2.2/500	256/242

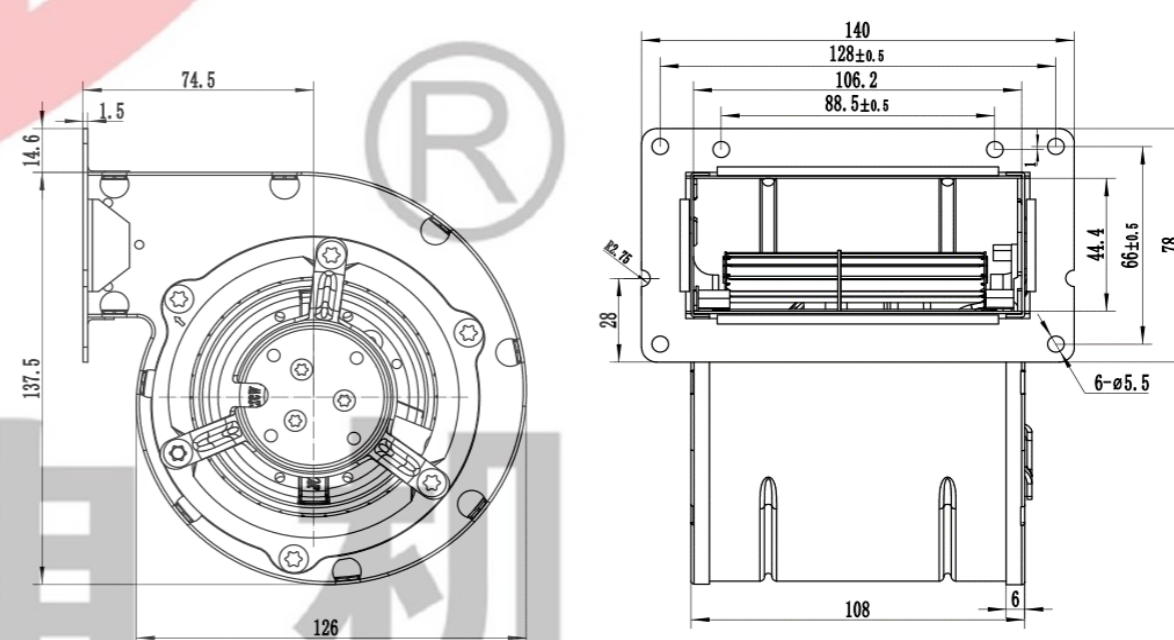

九龙电机

AC Axial Fan  
AC轴流风机

AC All-Metal Axial Fan  
AC全金属轴流风扇

DC Axial Fan  
DC轴流风机

DC Centrifugal Fan  
DC离心风机

EC Axial Fan  
EC轴流风机

EC Centrifugal Fan  
EC离心风机

AC Centrifugal Fan  
AC离心风机

Fan Accessories  
风机配件



JULONG MOTOR  
AC/DC FANS COOLING FANS



本样机仅供参考，具体以实物为准。  
This sample book is for reference only, please refer to the specification for details.  
如需特殊电压也可根据需求提供，本公司保留技术知识产权。  
Special voltage may be provided flexibly according to the requirement, although technical intellectual property reserved.

Http://www.xtgygs.cn

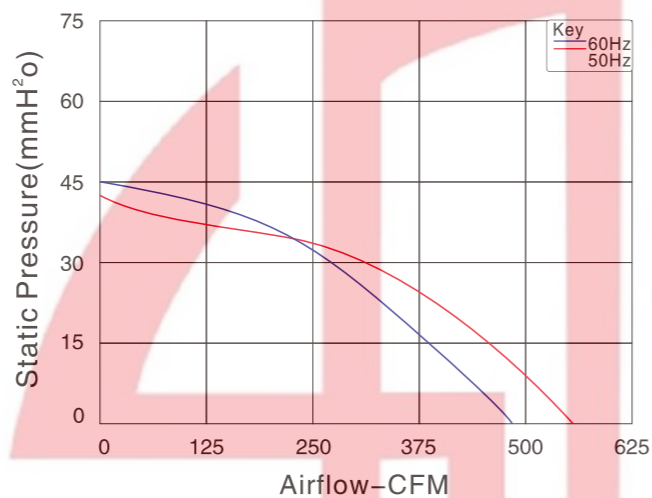

尺寸 Size: Ø133mm × 190mm  
重量 Weight: 3800g  
风叶 Impeller Material: Metal  
马达 Motor: Capacitor-Run And External Rotor Induction Motor  
引线 Lead Wire: Teflon 22# UL 1332(Optional)  
温度范围 Operating Temperature: -10°C~+65°C  
防护等级 Type of protection: IP44  
绝缘等级 Insulation class: "F"

产品型号 Model	电压 Voltage VAC	频率 Freq. Hz	电流 Current A	功率 Power W	转速 Speed RPM	噪音 Noise dB(A)	电容 Capacitor μF/VAC	风量 Air Flow CFM
JS133A2E01-W	115	60	1.5	200	1350	56	20/450	565
JS133A2E02-W	230	50/60	0.8/1.3	180/220	1350/1150	56/59	5/500	565/493
JS133A2E03-W	380	50	0.3	100	1350	55	/	565
JS133A2E07-W	440	50	0.3	100	1350	56	/	565

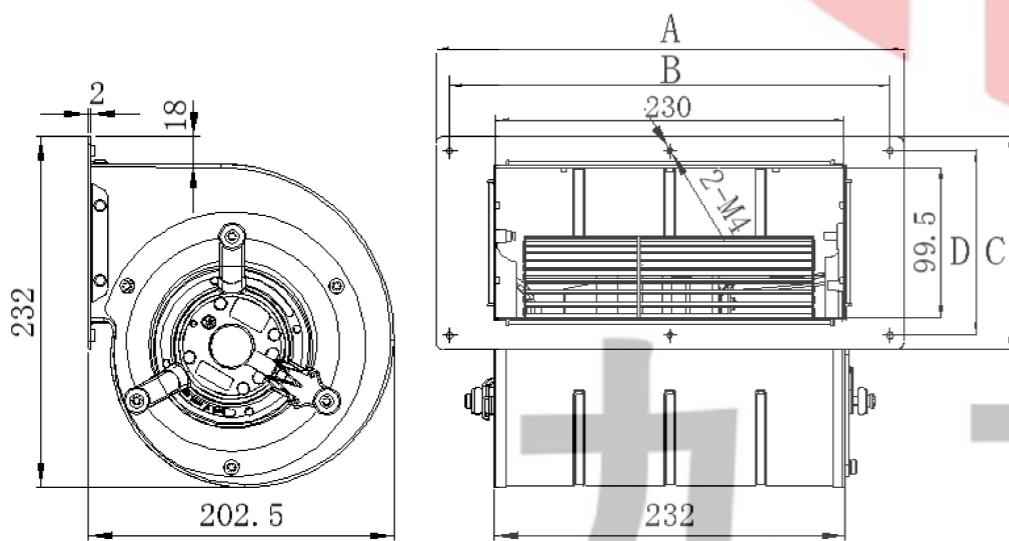

型号	A	B	C	D	E
大出风口	309.5	291	140.5	122	4.5
小出风口	270	254	142	126	5.5

订货时说明产品出风口类别，默认大出风口发货。

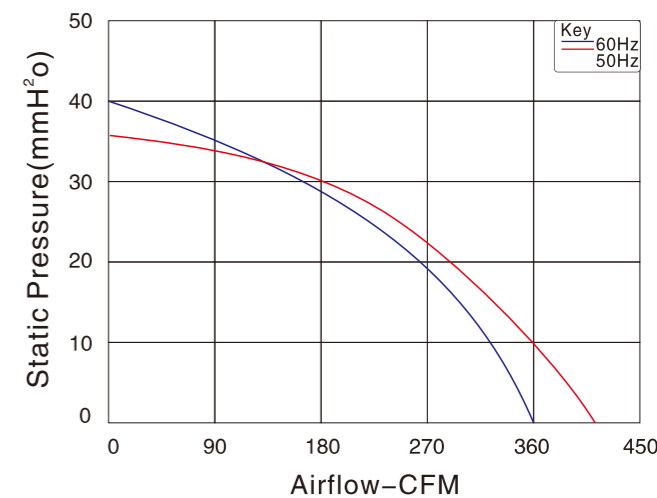

尺寸 Size: Ø133mm × 190mm  
重量 Weight: 3800g  
风叶 Impeller Material: Metal  
马达 Motor: Capacitor-Run And External Rotor Induction Motor  
引线 Lead Wire: Teflon 22# UL 1332(Optional)  
温度范围 Operating Temperature: -10°C~+65°C  
防护等级 Type of protection: IP44  
绝缘等级 Insulation class: "F"

产品型号 Model	电压 Voltage VAC	频率 Freq. Hz	电流 Current A	功率 Power W	转速 Speed RPM	噪音 Noise dB(A)	电容 Capacitor μF/VAC	风量 Air Flow CFM
JS133B2E02-W	230	50/60	0.85/0.95	190/220	1550/1800	56/59	5/500	390/361
JS133B2E03-W	380	50	0.42	115	1550	56	/	390

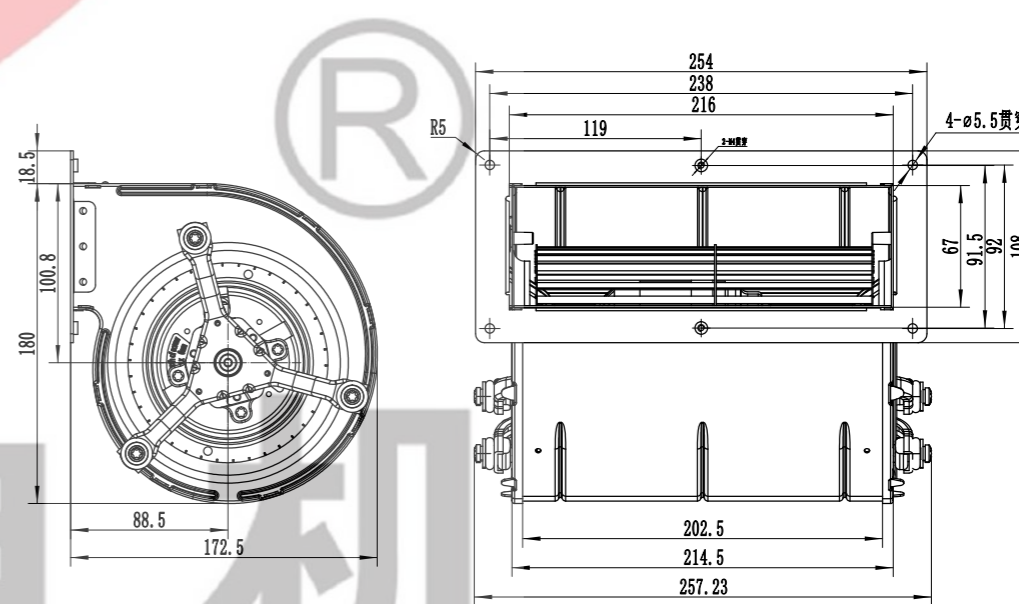

九 龙 电 机



JULONG MOTOR  
AC/DC FANS COOLING FANS



本样图仅供参考，具体以实物为准。  
This sample book is for reference only. Please refer to the specification for details.  
如需特殊电压也可根据需求提供。本公司保留技术知识产权。  
Special voltage may be provided flexibly according to the requirement. All technical modification rights reserved.

Http://www.xtgygs.cn

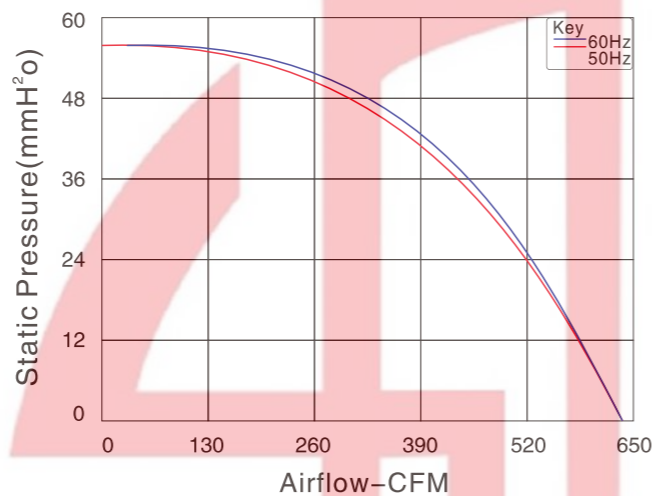

尺寸 Size: Ø146mm × 150mm  
重量 Weight: 3300g  
风叶 Impeller Material: PP  
马达 Motor: Capacitor-Run And External Rotor Induction Motor  
引线 Lead Wire: Teflon 22# UL 1332(Optional)  
温度范围 Operating Temperature: -10°C~+65°C  
防护等级 Type of protection: IP44  
绝缘等级 Insulation class: "F"

产品型号 Model	电压 Voltage VAC	频率 Freq. Hz	电流 Current A	功率 Power W	转速 Speed RPM	噪音 Noise dB(A)	电容 Capacitor μF/VAC	风量 Air Flow CFM
JS146A2E01-W	115	60	3	300	1800	66	25/450	624
JS146A2E02-W	230	50	1.2	300	1800	66	10/500	624

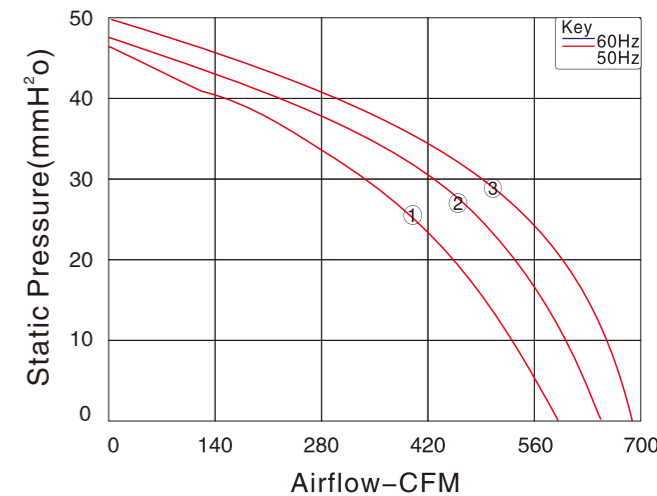
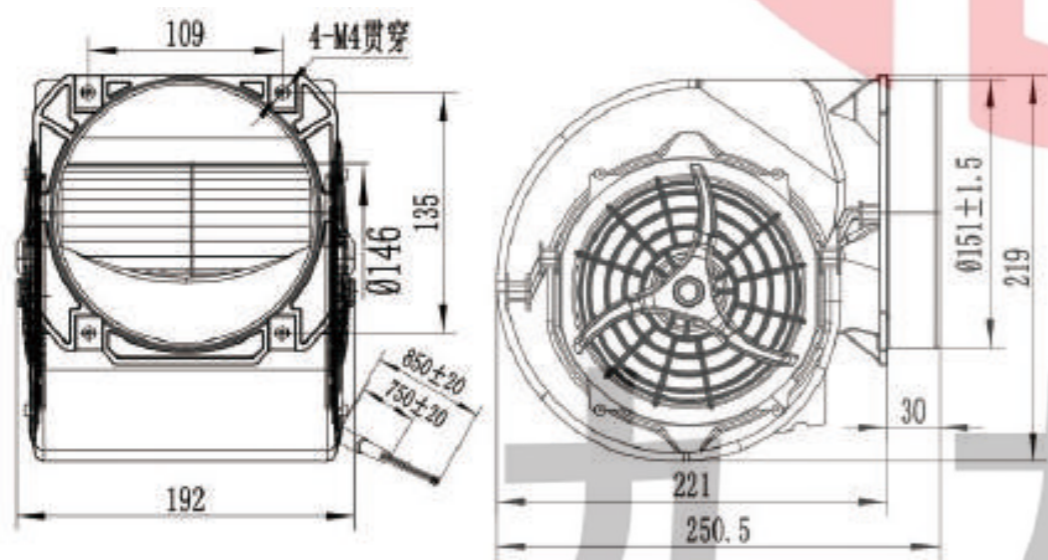

尺寸 Size: Ø146mm × 190mm  
重量 Weight: 3800g  
风叶 Impeller Material: Metal  
马达 Motor: Capacitor-Run And External Rotor Induction Motor  
引线 Lead Wire: Teflon 22# UL 1332(Optional)  
温度范围 Operating Temperature: -10°C~+65°C  
防护等级 Type of protection: IP44  
绝缘等级 Insulation class: "F"

产品型号 Model	电压 Voltage VAC	频率 Freq. Hz	电流 Current A	功率 Power W	转速 Speed RPM	噪音 Noise dB(A)	电容 Capacitor μF/VAC	风量 Air Flow CFM
JS146B2E02-W ①	230	50	1.1	222	1250	62	5/500	576
JS146B2E02-W ②	230	50	1.25	274	1450	67	8/500	656
JS146B2E02-W ③	230	50	1.5	331	1650	69	8/500	697

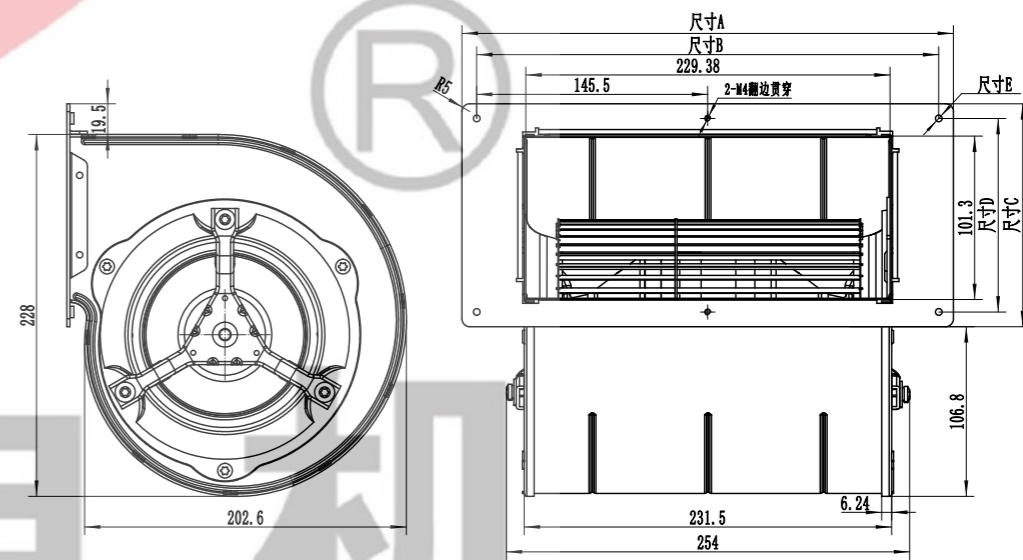

型号	A	B	C	D	E
大出风口	309.5	291	140.5	122	4.5
小出风口	270	254	142	126	5.5

订货时说明产品出风口类别，默认大出风口发货。

九龙电机



JULONG MOTOR  
AC/DC FANS COOLING FANS



本样图仅供参考，具体以实物为准。  
This sample book is for reference only, please refer to the specification for details.  
如需特殊电压也可根据需求提供，本公司保留技术更改权利。  
Special voltage may be provided flexibly according to the requirement, although technical modification rights reserved.

Http://www.xtgygs.cn

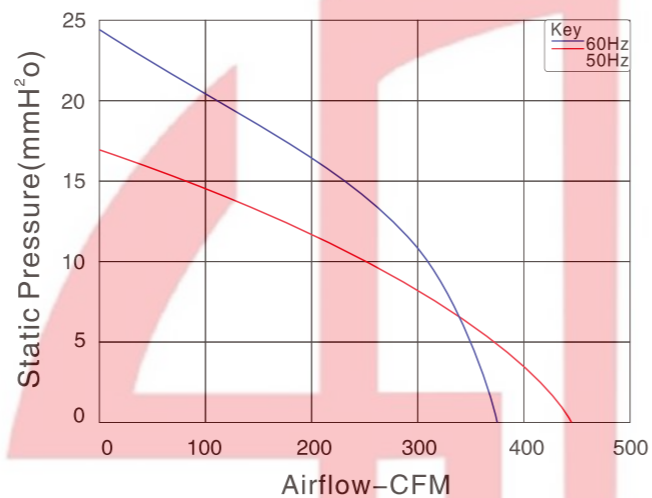

尺寸 Size: Ø151mm × 195mm  
重量 Weight: 3800g  
风叶 Impeller Material: Metal  
马达 Motor: Capacitor-Run And External Rotor Induction Motor  
引线 Lead Wire: Teflon 22# UL 1332(Optional)  
温度范围 Operating Temperature: -10°C~+65°C  
防护等级 Type of protection: IP44  
绝缘等级 Insulation class: "F"

产品型号 Model	电压 Voltage VAC	频率 Freq. Hz	电流 Current A	功率 Power W	转速 Speed RPM	噪音 Noise dB(A)	电容 Capacitor μF/VAC	风量 Air Flow CFM
JS151A4E02-W	230	50/60	0.42/0.45	90/95	950/1100	54/56	2/500	383/441

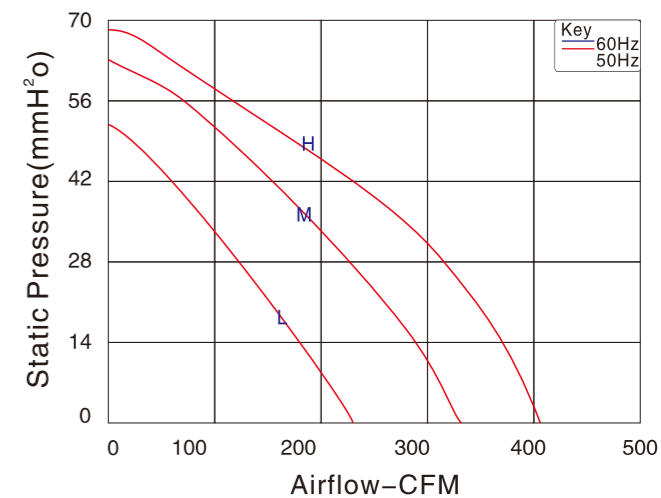
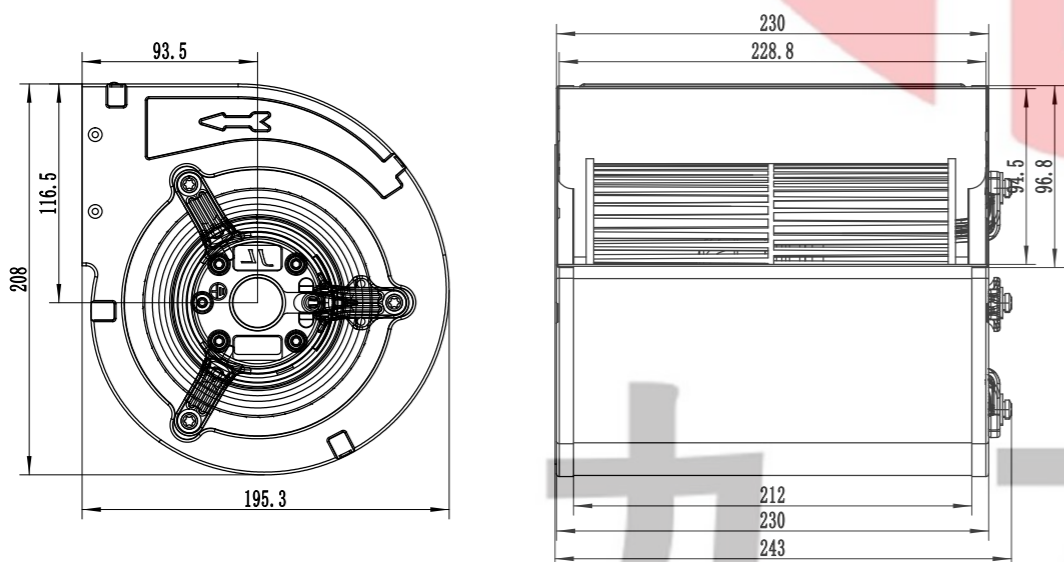

尺寸 Size: Ø160mm × 74mm  
重量 Weight: 3800g  
风叶 Impeller Material: SGCC  
马达 Motor: Capacitor-Run And External Rotor Induction Motor  
引线 Lead Wire: AWG#UL1332 22#(Optional)  
温度范围 Operating Temperature: -10°C~+65°C  
防护等级 Type of protection: IP42  
绝缘等级 Insulation class: "F"

产品型号 Model	电压 Voltage VAC	频率 Freq. Hz	电流 Current A	功率 Power W	转速 Speed RPM	噪音 Noise dB(A)	电容 Capacitor μF/VAC	风量 Air Flow CFM
JS160A2E02-W	220	50	1.1	241	1400	60	5/500	420
			0.9	185	1150	55		340
			0.7	137	800	51		241

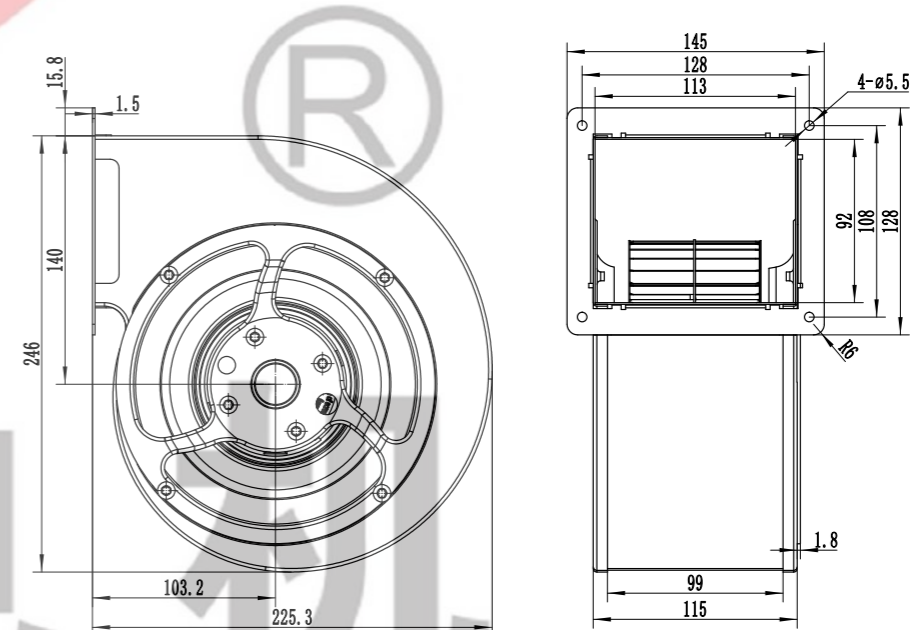

九 龙 电 机

AC Axial Fan  
AC轴流风机

AC All-Metal Axial Fan  
AC全金属轴流风扇

DC Axial Fan  
DC轴流风机

DC Centrifugal Fan  
DC离心风机

EC Axial Fan  
EC轴流风机

EC Centrifugal Fan  
EC离心风机

AC Centrifugal Fan  
AC离心风机

Fan Accessories  
风机配件



JULONG MOTOR  
AC/DC FANS COOLING FANS



尺寸 Size:  $\varnothing 160\text{mm} \times 250\text{mm}$   
重量 Weight: 5800g  
风叶 Impeller Material: SGCC  
马达 Motor: Capacitor-Run And External Rotor Induction Motor  
引线 Lead Wire: AWG#UL1332 22#(Optional)  
温度范围 Operating Temperature:  $-10^{\circ}\text{C} \sim +65^{\circ}\text{C}$   
防护等级 Type of protection: IP20  
绝缘等级 Insulation class: "F"

产品型号 Model	电压 Voltage VAC	频率 Freq. Hz	电流 Current A	功率 Power W	转速 Speed RPM	噪音 Noise dB(A)	电容 Capacitor $\mu\text{F}/\text{VAC}$	风量 Air Flow CFM
JS160B2E02-W	230	50	2.1	560	1300	64	15/500	870

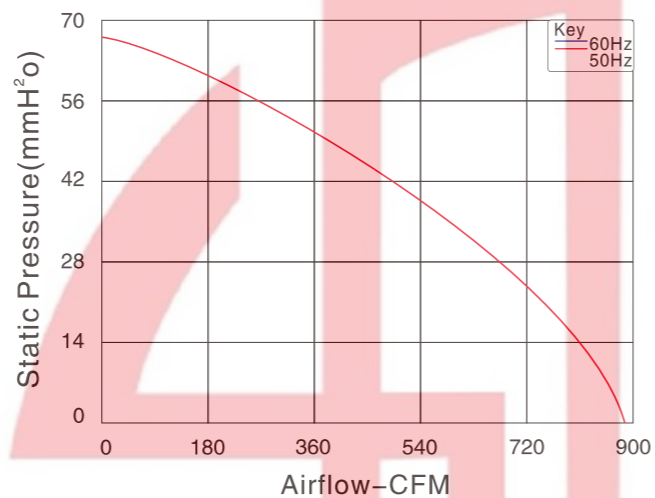
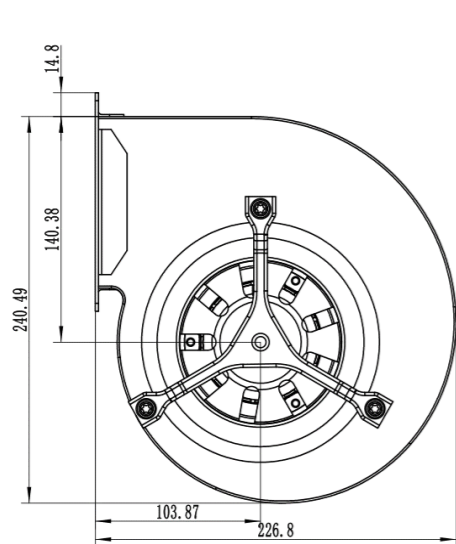

尺寸 Size:  $\varnothing 237\text{mm} \times 216\text{mm} - \varnothing 100\text{mm}$   
重量 Weight: 3600g  
外框 Shell: SGCC  
马达 Motor: DC brushless external rotor Motor  
引线 Lead Wire: AWG 20# UL 1007  
温度范围 Operating Temperature:  $-10^{\circ}\text{C} \sim +65^{\circ}\text{C}$   
防护等级 Type of protection: IP44  
绝缘等级 Insulation class: "F"

产品型号 Model	电压 Voltage VAC	频率 Freq. Hz	电流 Current A	功率 Power W	转速 Speed RPM	噪音 Noise dB(A)	风量 Air Flow CFM	重量 Weight
JG100A2E01	115	60	0.48	65	2500	48	112	3.6KG
JG100B2E01	115	60	0.92	115	2900	51	127	3.6KG
JG100C2E02	230	50	0.2	50	2500	38	106	3.6KG
JG100D2E02	230	50	0.28	65	2600	45	112	3.6KG
JG100E2E02	230	50	0.37	80	2600	65	141	3.6KG

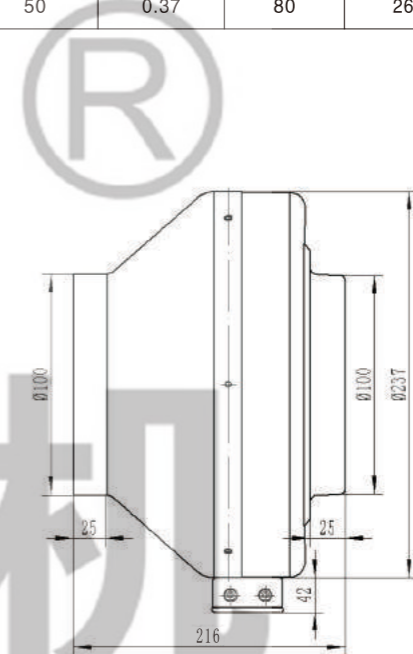
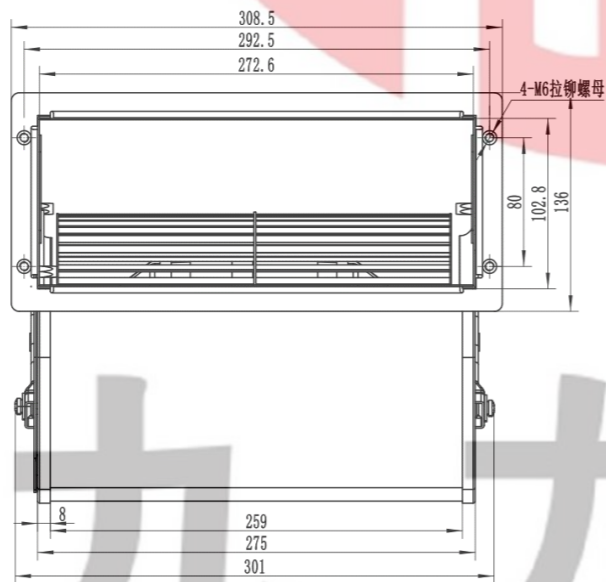
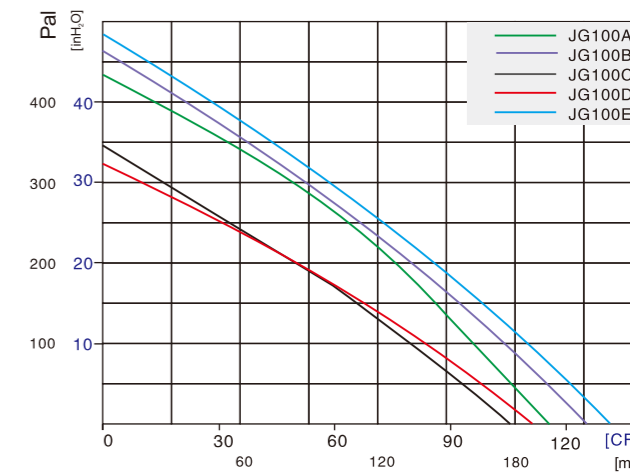

九 龙 电 机

本样机仅供参考，具体以规格书为准。  
This sample book is for reference only. Please refer to the specification for details.  
如需特殊电压也可根据规格书提供。本公司保留技术知识产权。  
Special voltage may be provided according to the enquiry. All technical modification rights reserved.

Http://www.xtgygs.cn

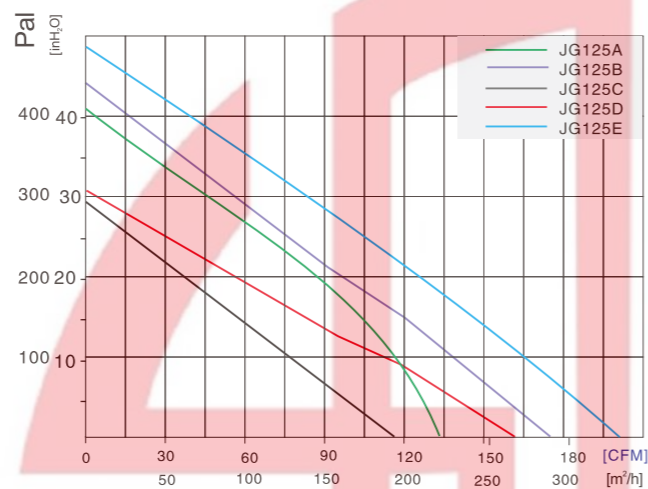

尺寸 Size: Ø237mm × 210mm-Ø125mm  
重量 Weight: 3800g  
外框 Shell: SGCC  
马达 Motor: Capacitor-Run And External Rotor Induction Motor  
引线 Lead Wire: Teflon 20# UL 1332(Optional)  
温度范围 Operating Temperature: -10°C~+65°C  
防护等级 Type of protection: IP44  
绝缘等级 Insulation class: "F"

产品型号 Model	电压 Voltage VAC	频率 Freq. Hz	电流 Current A	功率 Power W	转速 Speed RPM	噪音 Noise dB(A)	风量 Air Flow CFM	重量 Weight
JG125A2E01	115	60	0.5	60	2400	48	176	3.8KG
JG125B2E01	115	60	0.9	105	2900	50	138	3.8KG
JG125C2E02	230	50	0.15	45	2000	40	118	3.8KG
JG125D2E02	230	50	0.25	65	2650	46	165	3.8KG
JG125E2E02	230	50	0.7	85	2500	47	239	3.8KG

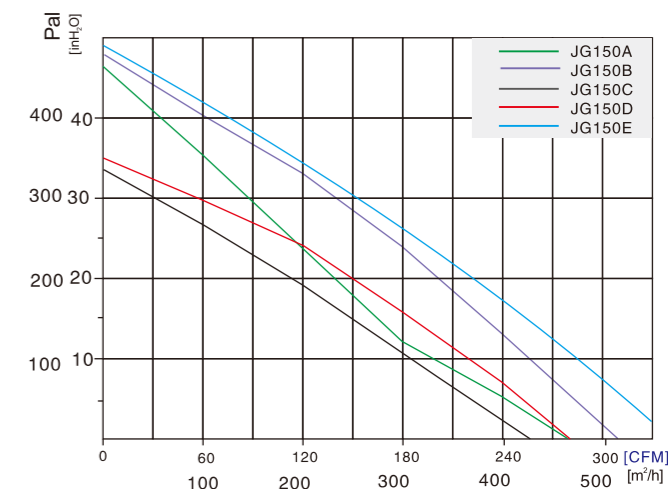
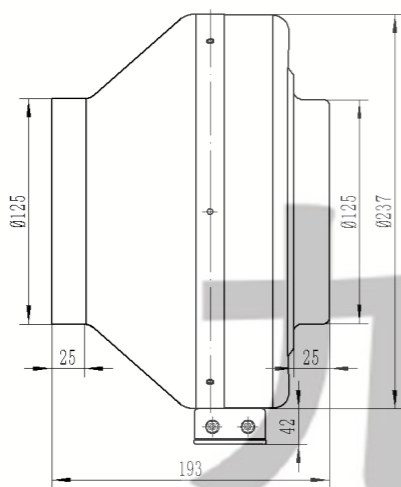

尺寸 Size: Ø278mm × 206mm-Ø150mm  
重量 Weight: 4000g  
外框 Shell: SGCC  
马达 Motor: Capacitor-Run And External Rotor Induction Motor  
引线 Lead Wire: Teflon 20# UL 1332(Optional)  
温度范围 Operating Temperature: -10°C~+65°C  
防护等级 Type of protection: IP44  
绝缘等级 Insulation class: "F"

产品型号 Model	电压 Voltage VAC	频率 Freq. Hz	电流 Current A	功率 Power W	转速 Speed RPM	噪音 Noise dB(A)	风量 Air Flow CFM	重量 Weight
JG150A2E01	115	60	0.58	68	2600	50	276	4KG
JG150B2E01	115	60	0.9	110	2900	52	306	4KG
JG150C2E02	230	50	0.2	50	2500	43	253	4KG
JG150D2E02	230	50	0.25	60	2600	47	282	4KG
JG150E2E02	230	50	0.95	130	2600	52	424	4KG

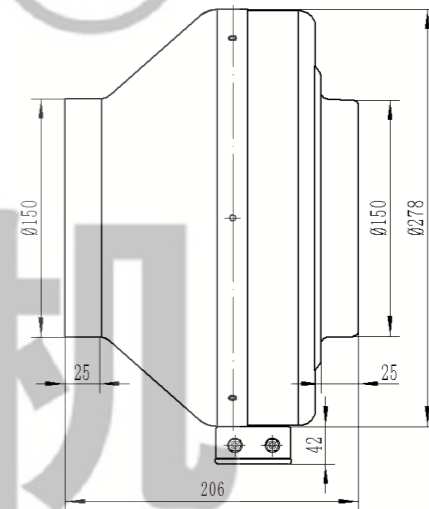
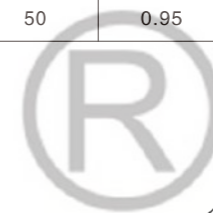

丸 龙 电 机



JULONG MOTOR  
AC/DC FANS COOLING FANS

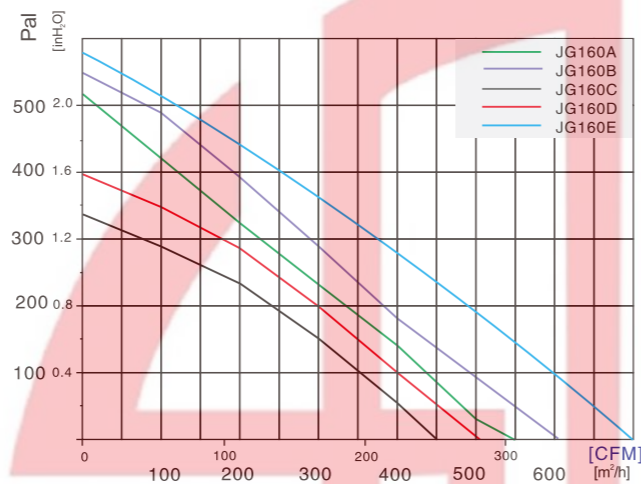

尺寸 Size: Ø278mm × 206mm – Ø160mm  
 重量 Weight: 4000g  
 外框 Shell: SGCC  
 马达 Motor: Capacitor-Run And External Rotor Induction Motor  
 引线 Lead Wire: Teflon 22# UL 1332(Optional)  
 温度范围 Operating Temperature: -10°C~+65°C  
 防护等级 Type of protection: IP44  
 绝缘等级 Insulation class: "F"

产品型号 Model	电压 Voltage VAC	频率 Freq. Hz	电流 Current A	功率 Power W	转速 Speed RPM	噪音 Noise dB(A)	风量 Air Flow CFM	重量 Weight
JG160A2E01	115	60	0.6	70	2700	51	276	4KG
JG160B2E01	115	60	1.2	130	3050	53	362	4KG
JG160C2E02	230	50	0.28	60	2600	44	269	4KG
JG160D2E02	230	50	0.55	125	2700	47	302	4KG
JG160E2E02	230	50	0.95	130	2600	52	445	4KG

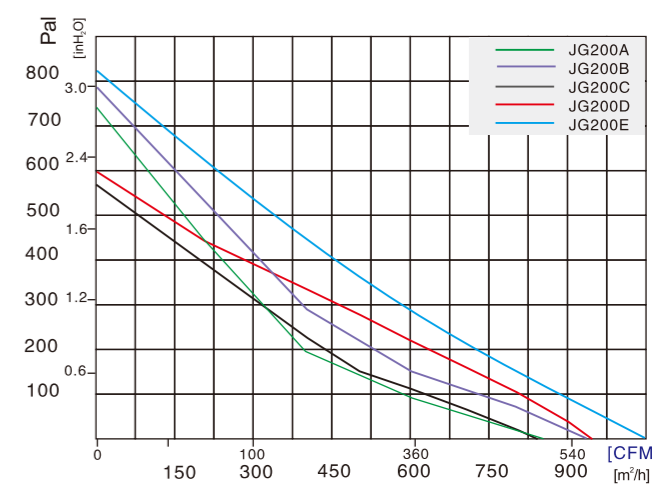
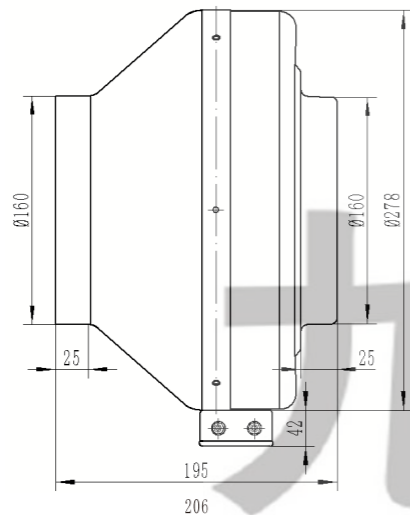

尺寸 Size: Ø333mm × 210mm – Ø200mm  
 重量 Weight: 6000g  
 外框 Shell: SGCC  
 马达 Motor: Capacitor-Run And External Rotor Induction Motor  
 引线 Lead Wire: Teflon 22# UL 1332(Optional)  
 温度范围 Operating Temperature: -10°C~+65°C  
 防护等级 Type of protection: IP44  
 绝缘等级 Insulation class: "F"

产品型号 Model	电压 Voltage VAC	频率 Freq. Hz	电流 Current A	功率 Power W	转速 Speed RPM	噪音 Noise dB(A)	风量 Air Flow CFM	重量 Weight
JG200A2E01	115	60	1.5	170	2300	51	501	6KG
JG200B2E01	115	60	1.7	190	2550	55	557	6KG
JG200C2E02	230	50	0.6	150	2300	51	501	6KG
JG200D2E02	230	50	0.6	160	2550	55	562	6KG
JG200E2E02	230	50	1.5	170	2500	53	589	6KG

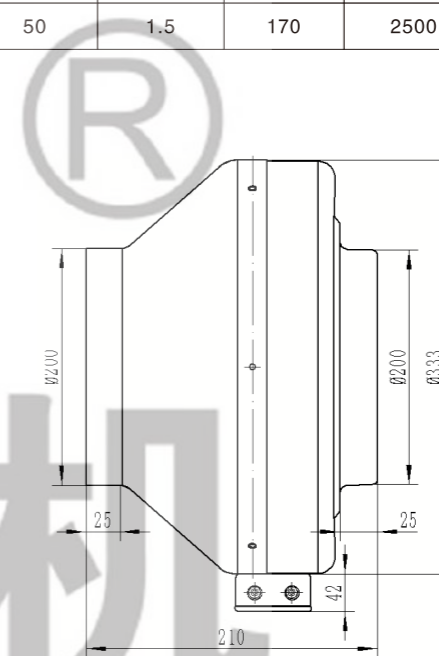

Http://www.xtgygs.cn



JULONG MOTOR  
AC/DC FANS COOLING FANS

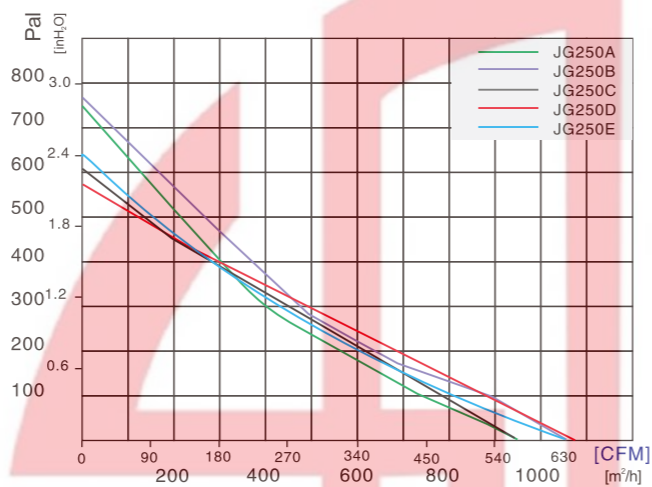
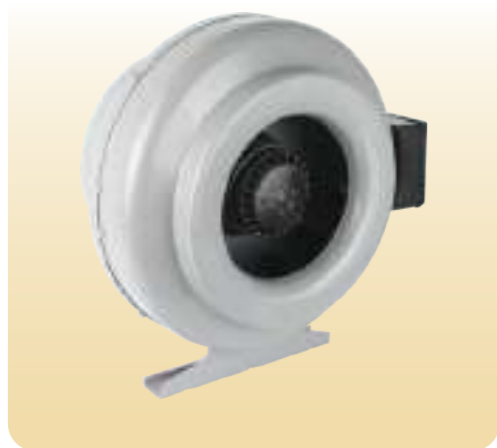

尺寸 Size:  $\varnothing 333\text{mm} \times 210\text{mm} - \varnothing 250\text{mm}$   
 重量 Weight: 6000g  
 外框 Shell: SGCC  
 马达 Motor: Capacitor-Run And External Rotor Induction Motor  
 引线 Lead Wire: Teflon 22# UL 1332(Optional)  
 温度范围 Operating Temperature:  $-10^{\circ}\text{C} \sim +65^{\circ}\text{C}$   
 防护等级 Type of protection: IP44  
 绝缘等级 Insulation class: "F"

产品型号 Model	电压 Voltage VAC	频率 Freq. Hz	电流 Current A	功率 Power W	转速 Speed RPM	噪音 Noise dB(A)	风量 Air Flow CFM	重量 Weight
JG250A2E01	115	60	2.1	150	2600	52	568	6KG
JG250B2E01	115	60	2	160	2500	50	645	6KG
JG250C2E02	230	50	0.6	230	2600	52	562	6KG
JG250D2E02	230	50	0.6	230	2500	50	636	6KG
JG250E2E02	230	50	0.7	180	2500	50	651	6KG

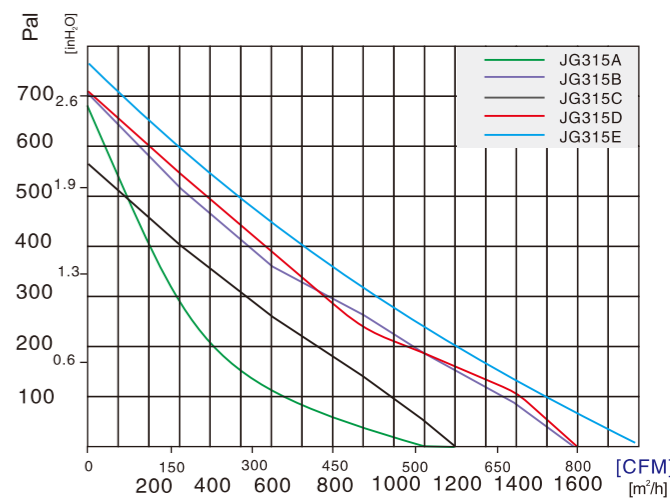
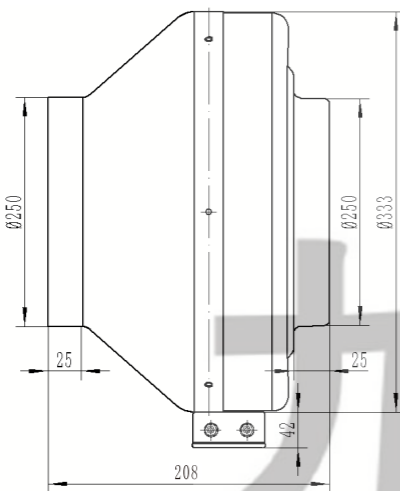

尺寸 Size:  $\varnothing 402\text{mm} \times 265\text{mm} - \varnothing 315\text{mm}$   
 重量 Weight: 8000g  
 外框 Shell: SGCC  
 马达 Motor: Capacitor-Run And External Rotor Induction Motor  
 引线 Lead Wire: Teflon 22# UL 1332(Optional)  
 温度范围 Operating Temperature:  $-10^{\circ}\text{C} \sim +65^{\circ}\text{C}$   
 防护等级 Type of protection: IP44  
 绝缘等级 Insulation class: "F"

产品型号 Model	电压 Voltage VAC	频率 Freq. Hz	电流 Current A	功率 Power W	转速 Speed RPM	噪音 Noise dB(A)	风量 Air Flow CFM	重量 Weight
JG315A2E01	115	60	1.8	320	2500	55	989	8KG
JG315B2E01	115	60	3	310	2500	55	989	8KG
JG315C2E02	230	50	0.65	160	2500	55	989	8KG
JG315D2E02	230	50	1	250	2500	55	989	8KG
JG315E2E02	230	50	1.1	280	2600	56	1105	8KG

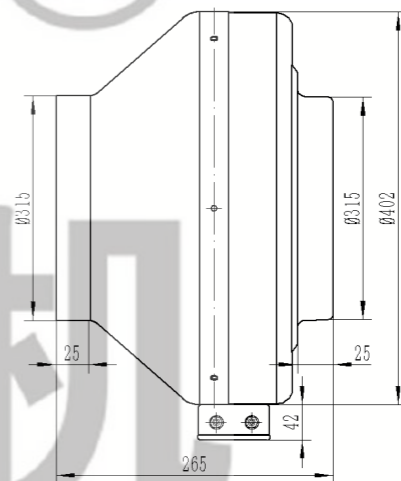
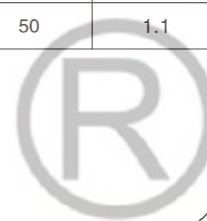

Http://www.xtgygs.cn